

ferro battuto | Schmiedeeisen | wrought iron

2013 ferro battuto

it | de | en



WOLFSGRUBER®
innovative steel design

Editorial

Product design: Wolfgruber GmbH

Arrangement / realisation: Wolfgruber GmbH

© Wolfgruber GmbH, 2013 All rights reserved. The texts are copyrighted

Use of any kind requires written permission.

info@wolfgruber.it

www.wolfgruber.it



WOLFSGRUBER®

innovative steel design

Wolfsgruber srl

Via Campi della Rienza, 6 | I-39031 Brunico (BZ)
Tel. +39 0474 552231 | Fax +39 0474 552247



Wolfsgruber GmbH

Rienzfeldweg 6 | I-39031 Bruneck (BZ)
info@wolfsgruber.it | www.wolfsgruber.it

Wolfsgruber Pescara

Via Breviglieri, 8 - 65128 PESCARA (PE)
Tel. +39 085 4326978 | Fax +39 085 4315141
pescara@wolfsgruber.it | www.wolfsgruber.it

Wolfsgruber Bamberg

Rheinstr. 3/A | D-96052 Bamberg
Tel. (0) 951 96830717 | Fax (0) 951 96830718
bamberg@wolfsgruber.de | www.wolfsgruber.de



Wolfsgruber Remscheid - Köln

Berghausen 1 | D-42859 Remscheid
Tel. (0) 2191 469525 | Fax (0) 2191 469526
remscheid@wolfsgruber.de | www.wolfsgruber.de

Wolfsgruber Leipzig

Angerstr. 2 | D-04827 Gerichshain
Tel. (0) 34292 64085 | Fax (0) 34292 79309
leipzig@wolfsgruber.de | www.wolfsgruber.de

Wolfsgruber Hamburg

Neuhöfer Str. 23, PuhsthoF (Haus 5) | D-21107 Hamburg
Tel. +49 (0) 40 4191 3750 | Fax +49 (0) 40 4191 3751
hamburg@wolfsgruber.de | www.wolfsgruber.de

Wolfsgruber Kramsach - Tirol

Amerling 33 | A-6233 Kramsach
Tel. (0) 5337 64258 | Fax (0) 5337 65451
kramsach@wolfsgruber.at | www.wolfsgruber.at



Wolfsgruber Paris

75 avenue Parmentier | F-75544 Paris Cedex 11
Tel. +33 (0) 1 40 21 24 58 | Fax: +33 (0) 1 40 21 24 59
info@wolfsgruber.fr | www.wolfsgruber.fr



Wolfsgruber Praha

Koněvova 2660/141 | CZ-13000 Praha 3
Tel. +420 226 217 057 | Fax +420 226 217 058
praha@wolfsgruber.it | www.wolfsgruber.it





IT | Esempi d'impiego ferro battuto
DE | Anwendungsbeispiele Schmiedeeisen
EN | Examples of application wrought iron
FR | Exemples d'applications en fer forgé
CZ | Příklady použití kovaných komponentů
PL | Przykłady zastosowania kutego żelaza



IT | Lavorazione moderna
DE | Moderne Metallgestaltung
EN | Modern metal moulding
FR | La conception moderne métal
CZ | Moderní kovový design
pl | Nowoczesna konstrukcja metalowa



IT | Paletti
DE | Stäbe
EN | Rods
FR | Balustres
CZ | Tyče
PL | Pręty



IT | Barre lavorate
DE | Stangenmaterial
EN | Bar stock
FR | Barres
CZ | Profily
PL | Material prętowy



IT | Elementi ornamentali
DE | Zierelemente
EN | Ornamental elements
FR | Éléments décoratifs
CZ | Dekorativní prvky
PL | Elementy ozdobne



IT | Particolari decorativi
DE | Kleinteile
EN | Small objects
FR | Accessoires
CZ | Male komponenty
PL | Male części



IT | Serramenti
DE | Beschläge
EN | Mountings
FR | Serrurerie
CZ | Kování
PL | Obicia



IT | Prodotti finiti
DE | Fertigungware
EN | Finished product
FR | Produits finis
CZ | Hotové výrobky
PL | Wyroby gotowe



IT | Ottone
DE | Messing
EN | Brass
FR | Laiton
CZ | Mosaz
PL | Mosiądz



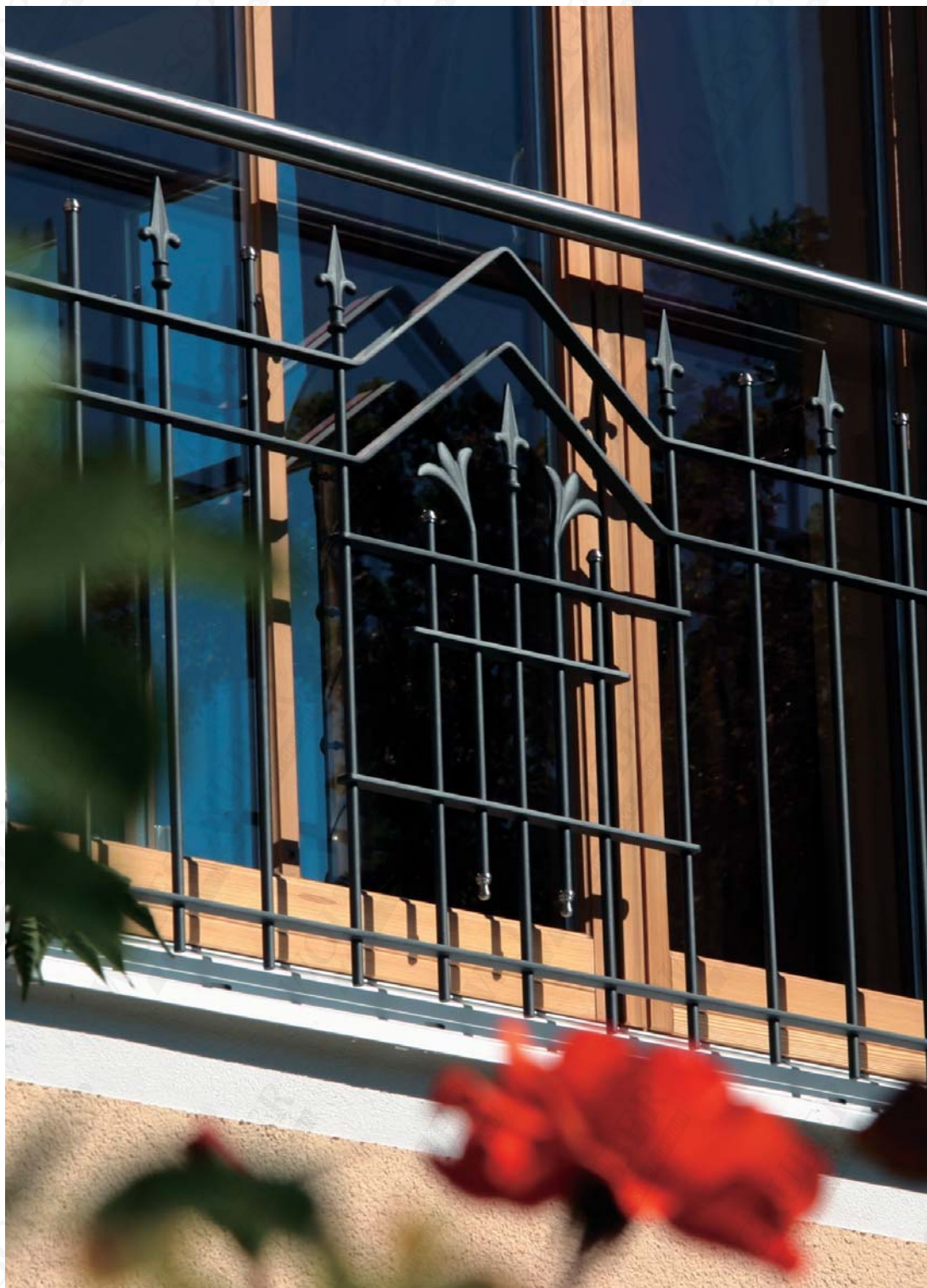

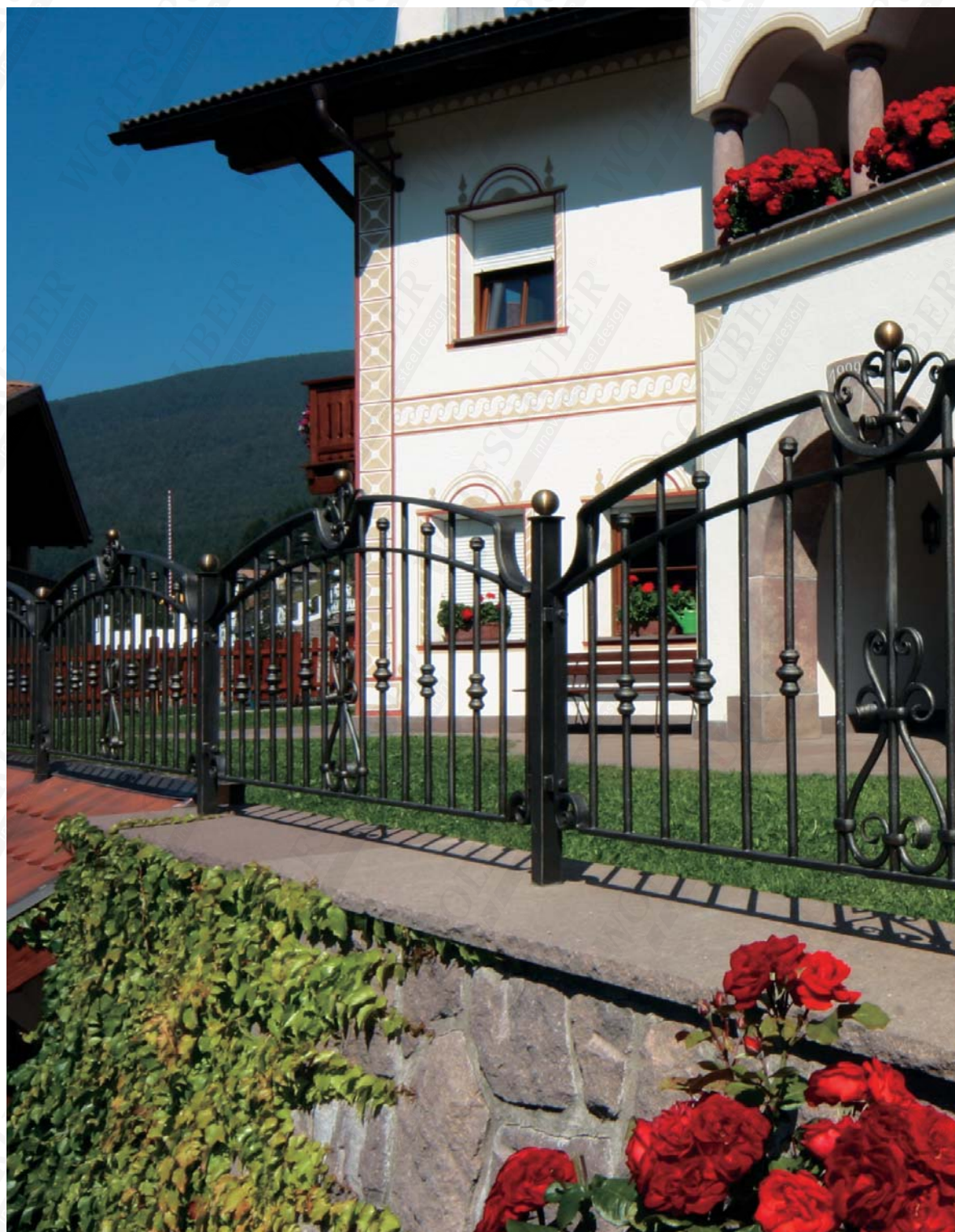





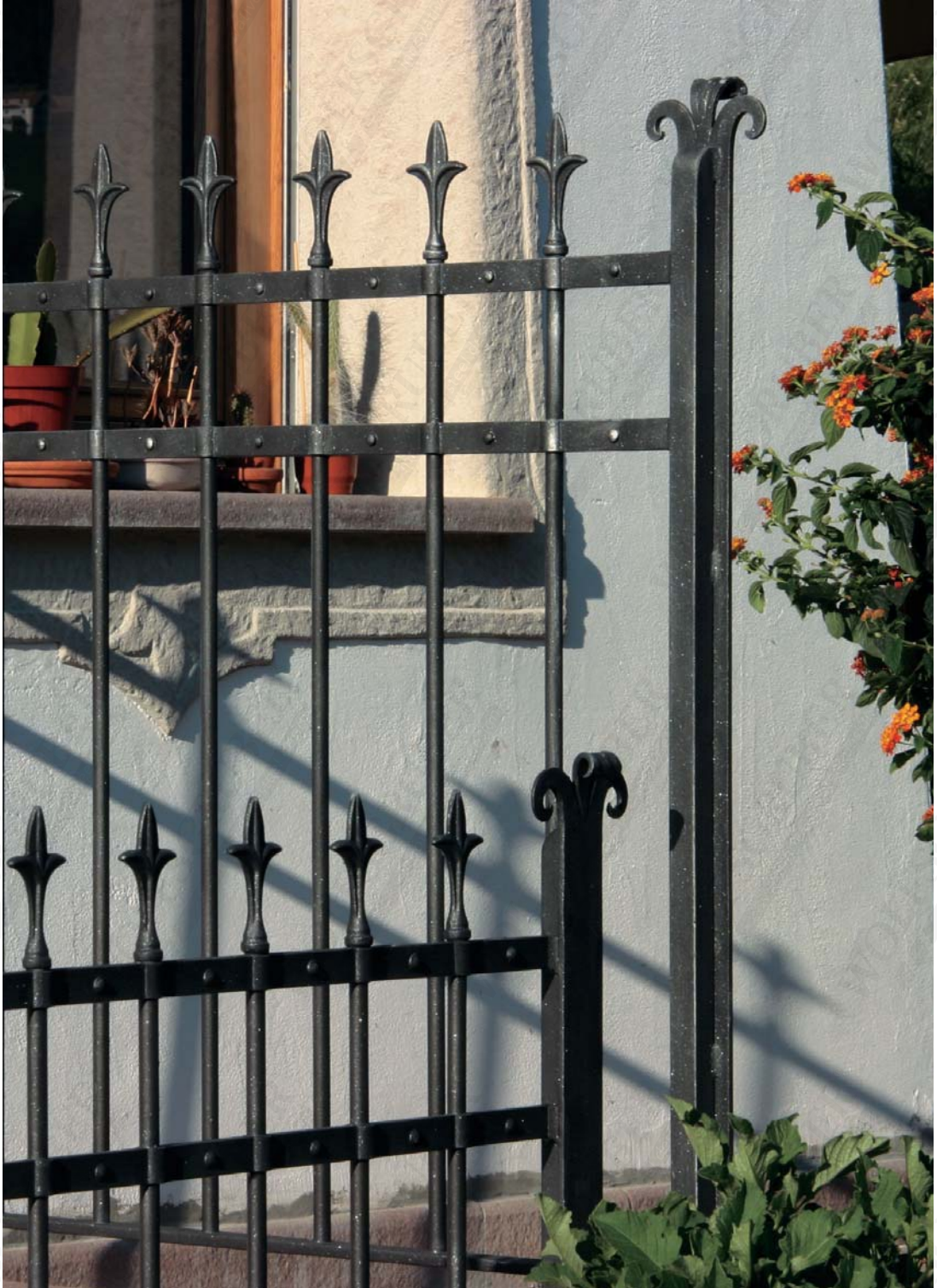









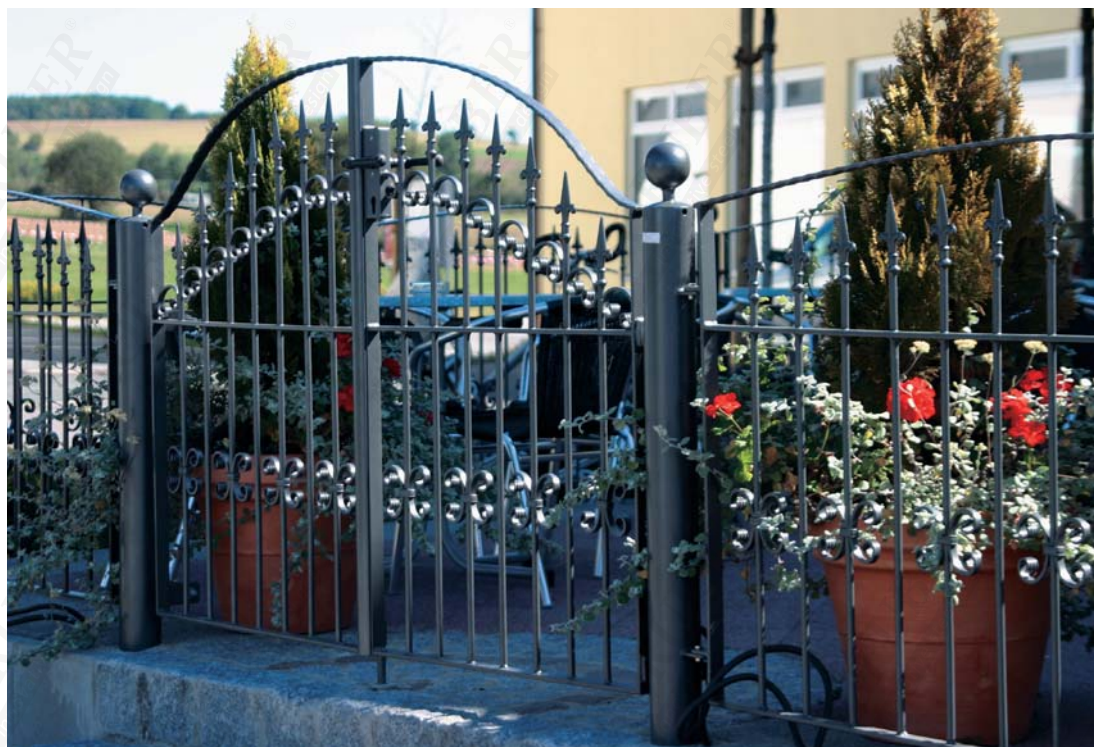























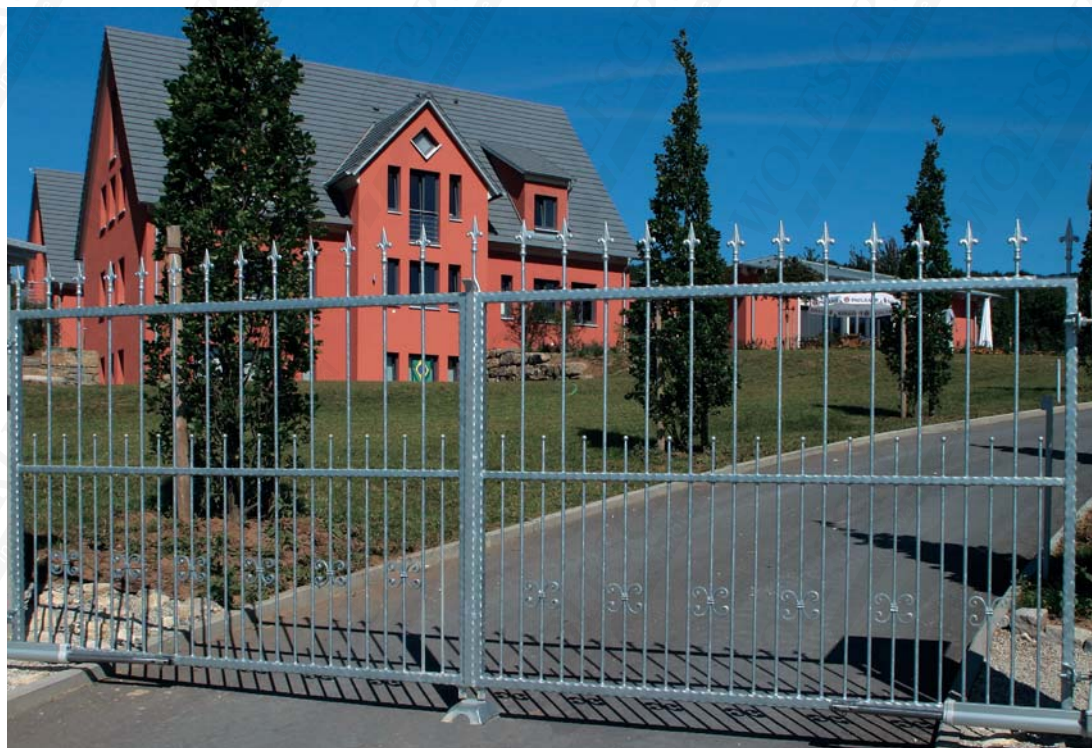

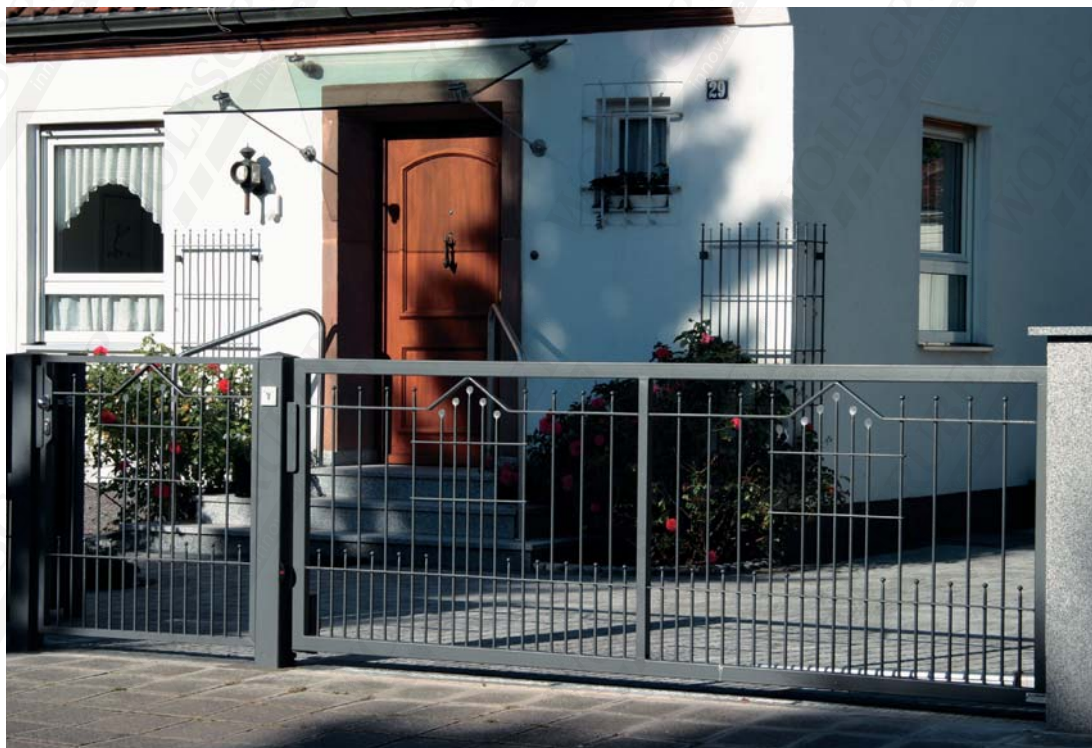

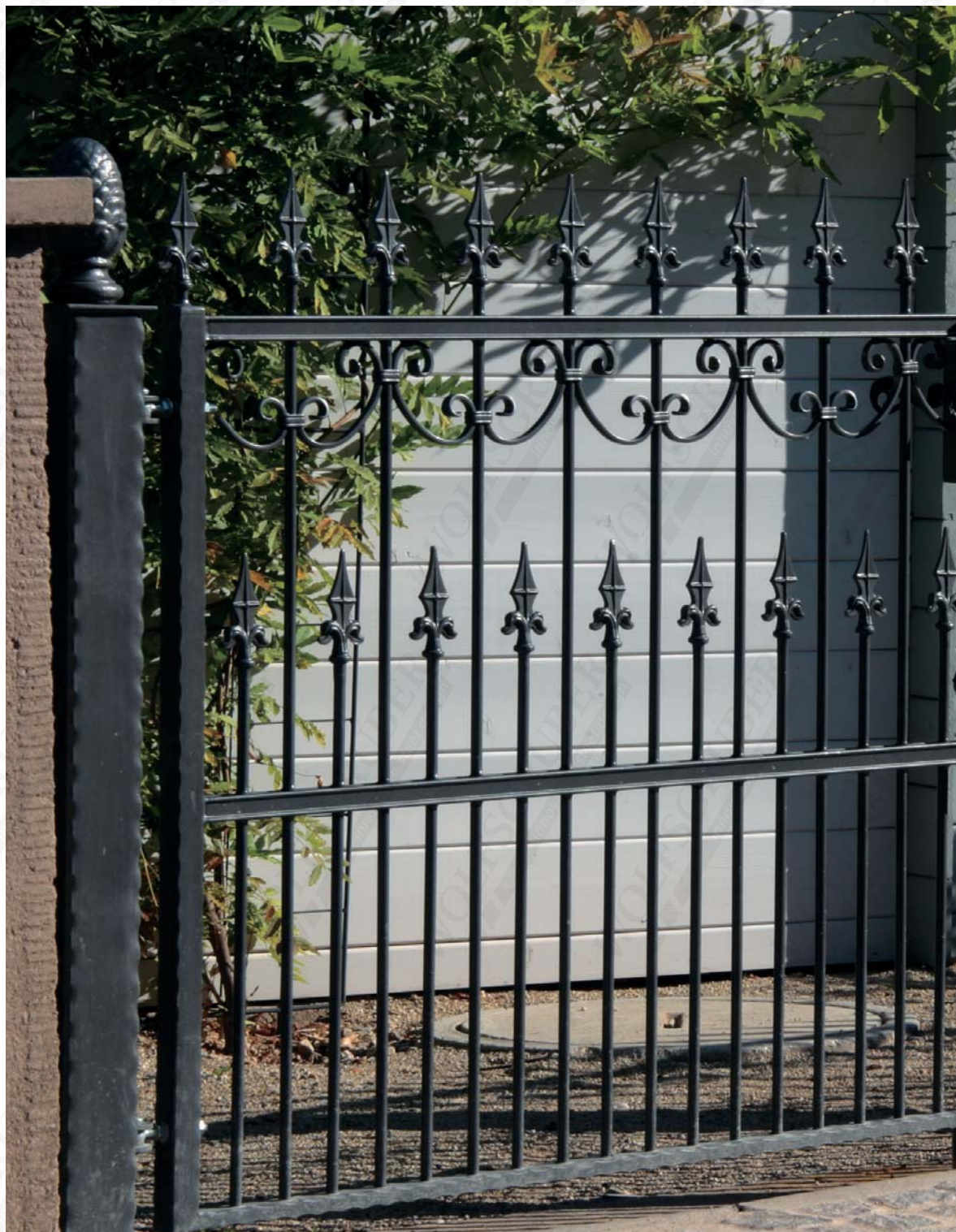





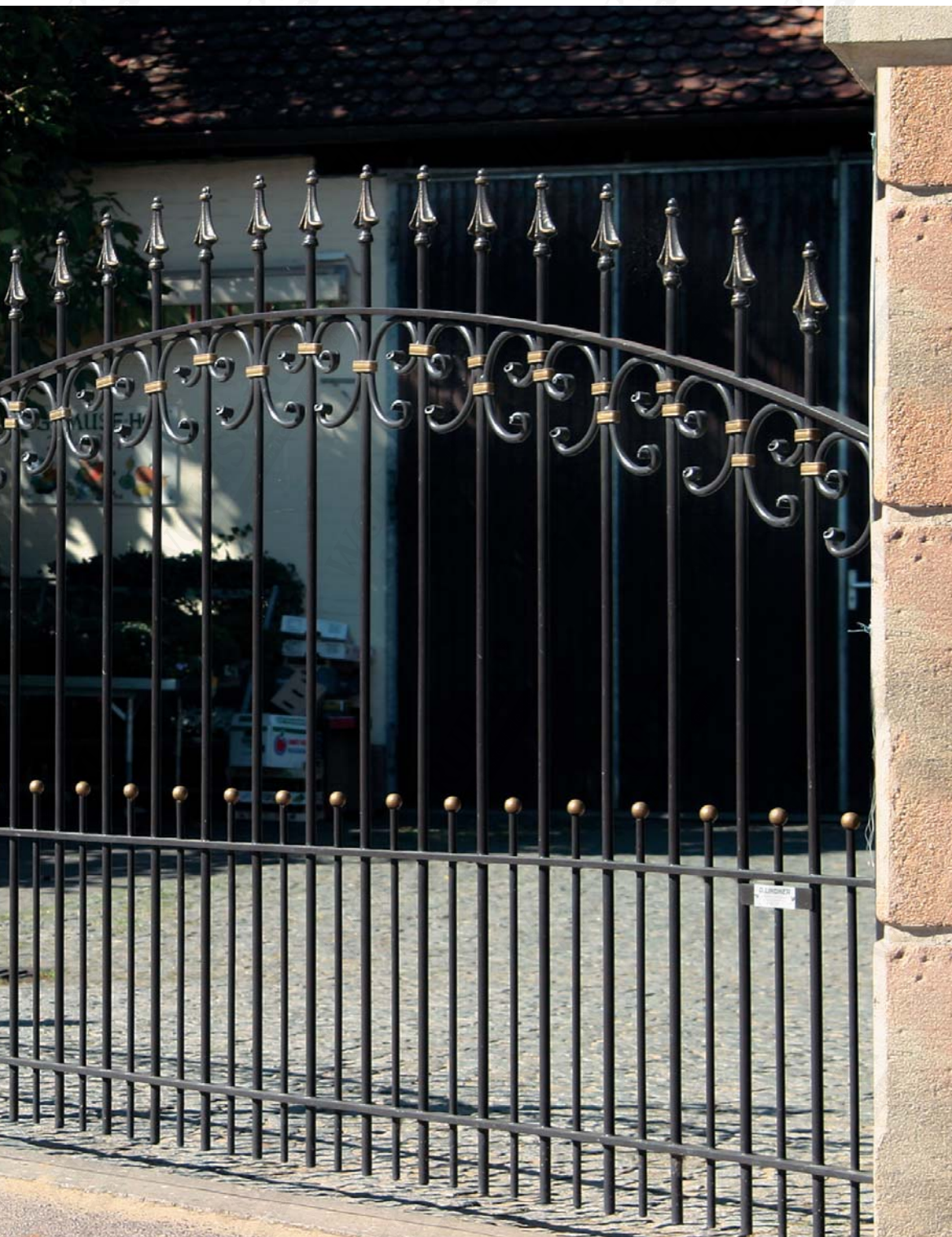









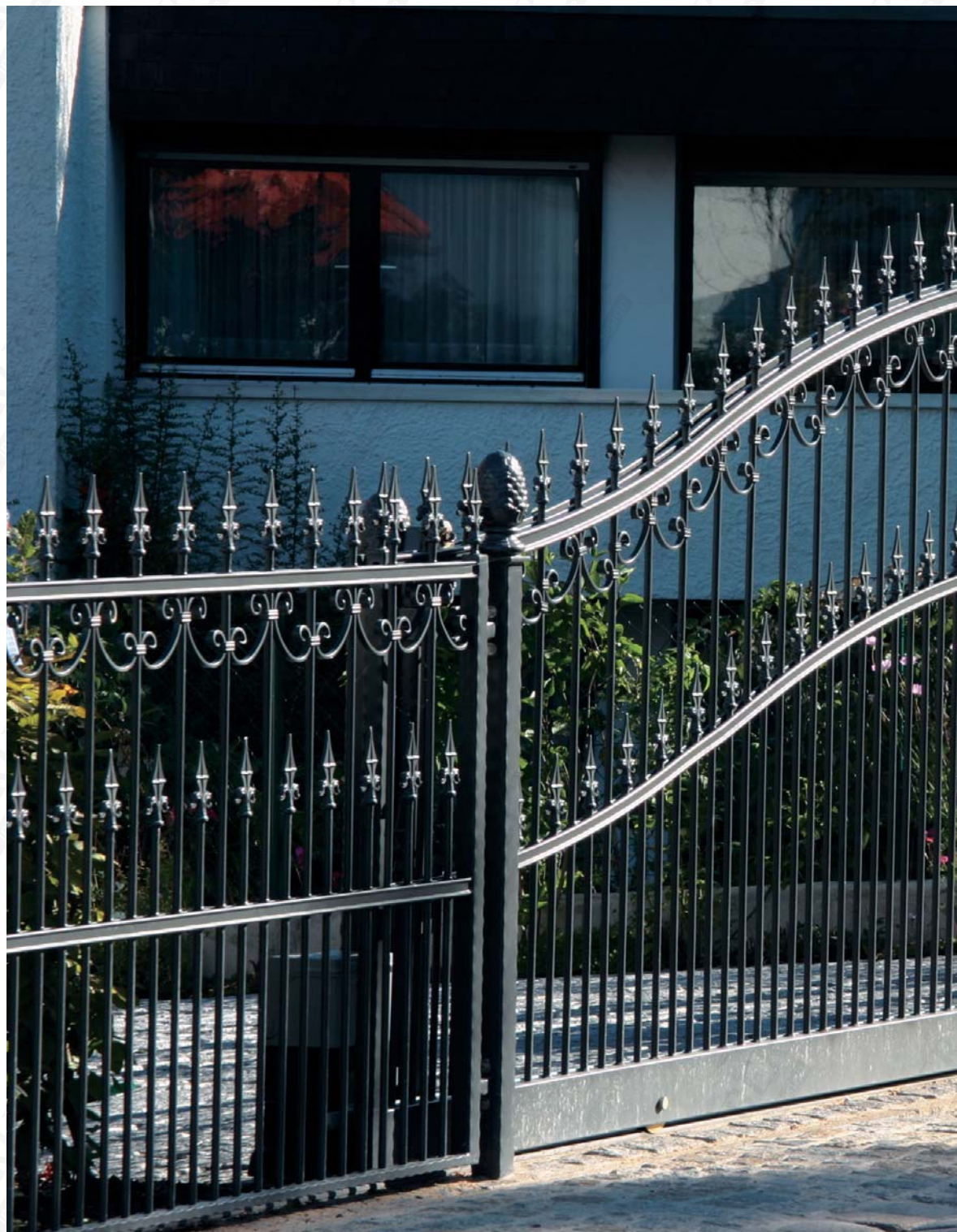



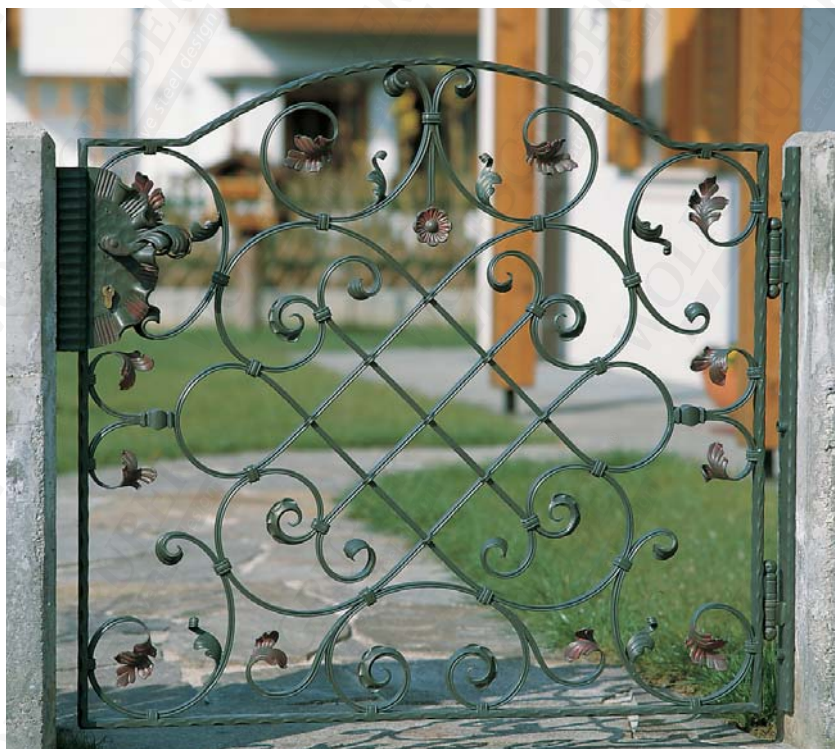









































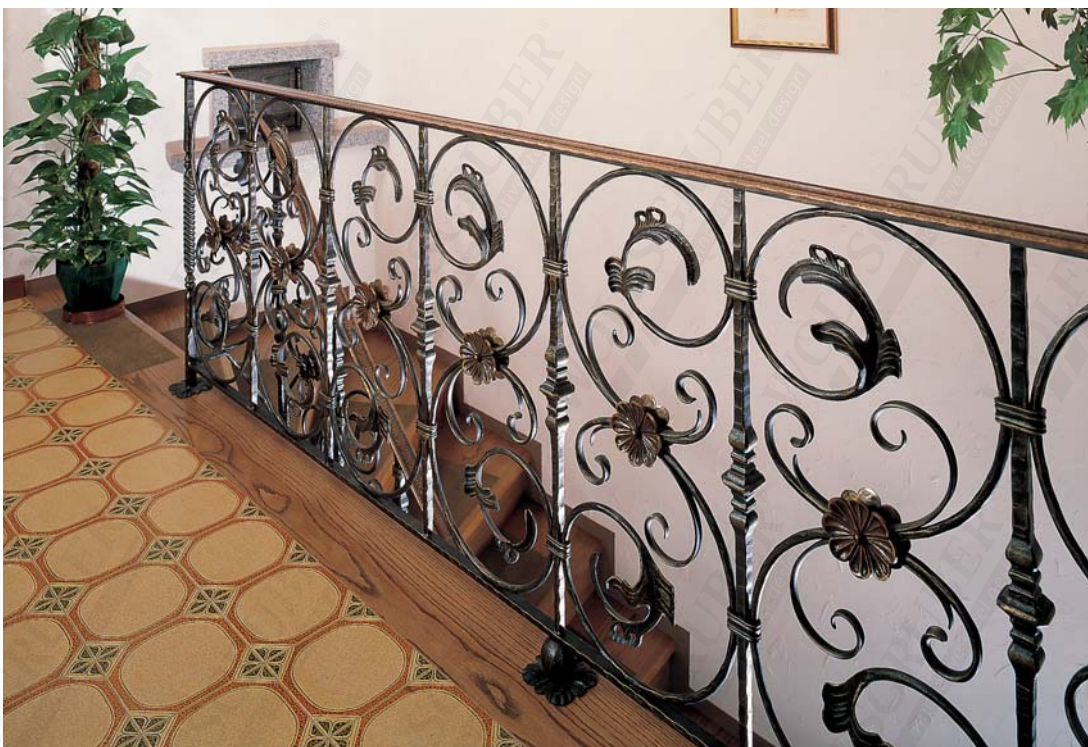

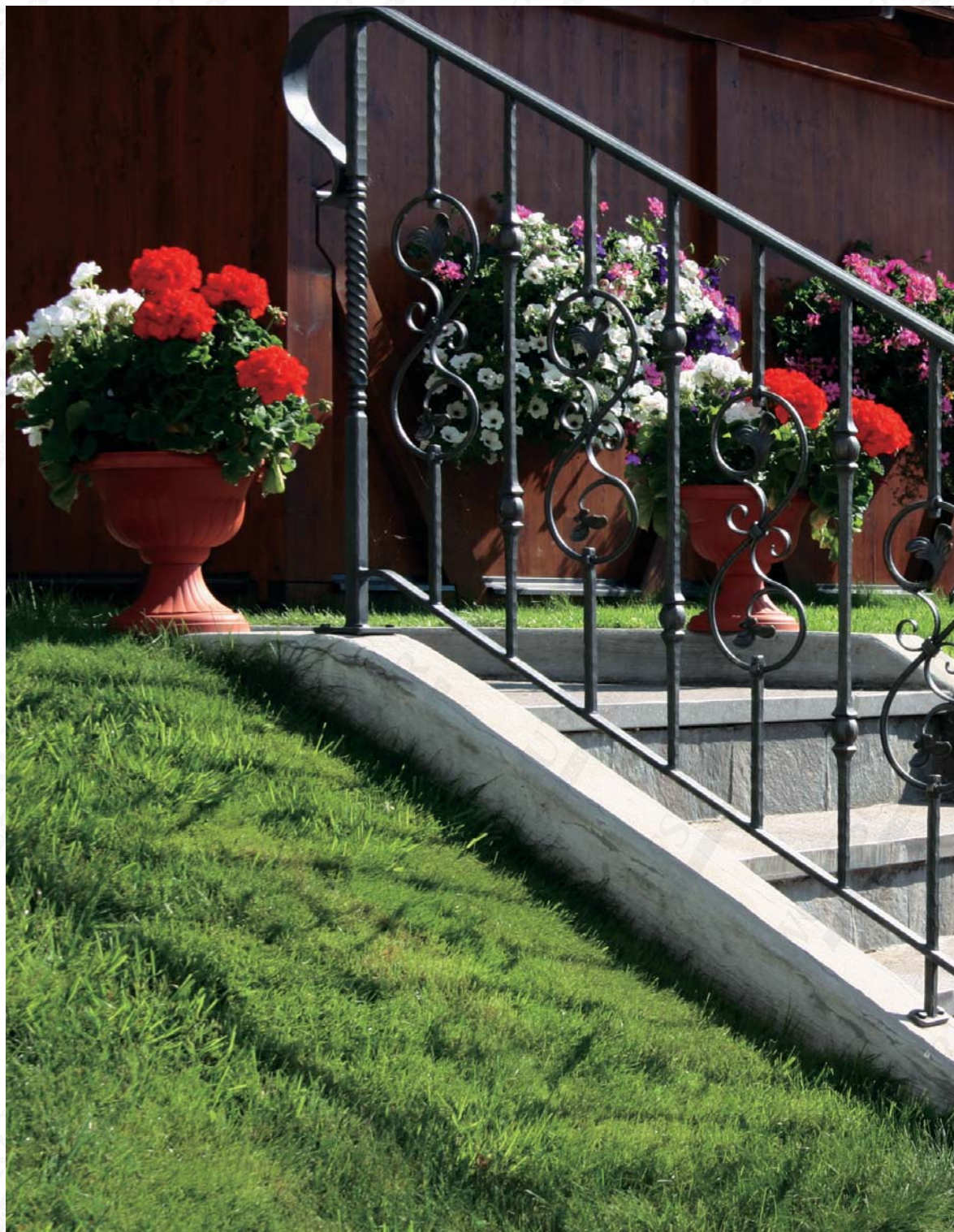











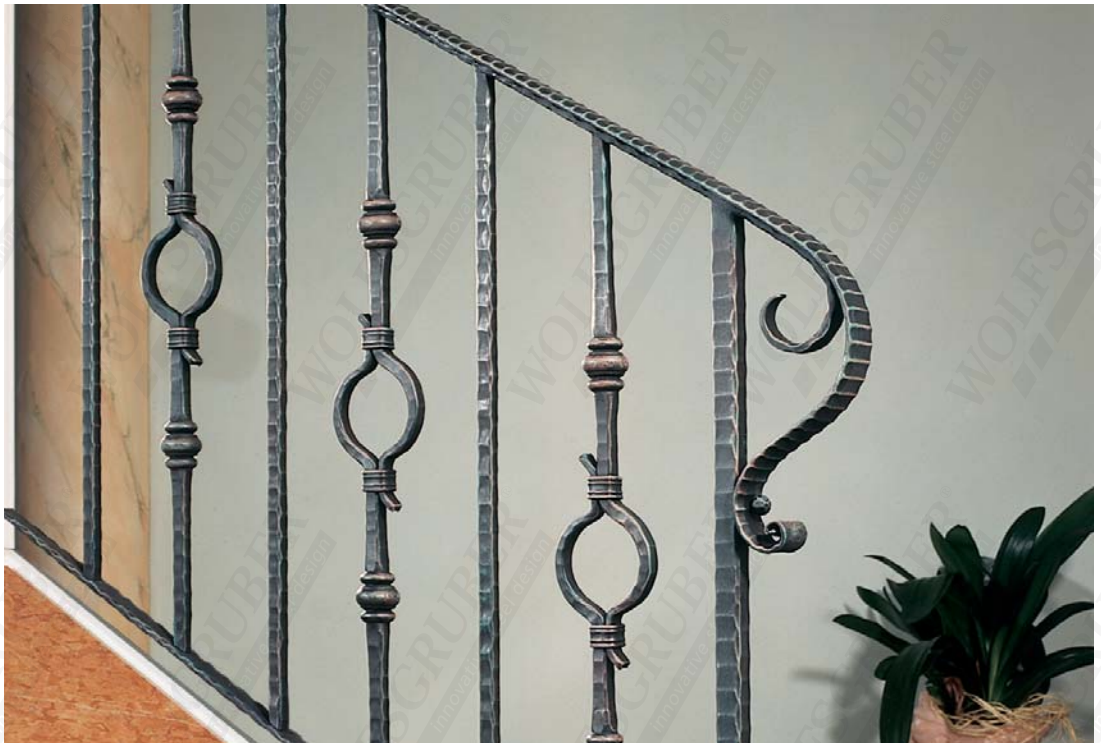

















































SERIE TRENTA

LAVORAZIONE MODERNA
MODERNE METALLGESTALTUNG
MODERN METAL MouldING



WOLFSGRUBER



innovative steel design



Serie
Trenta



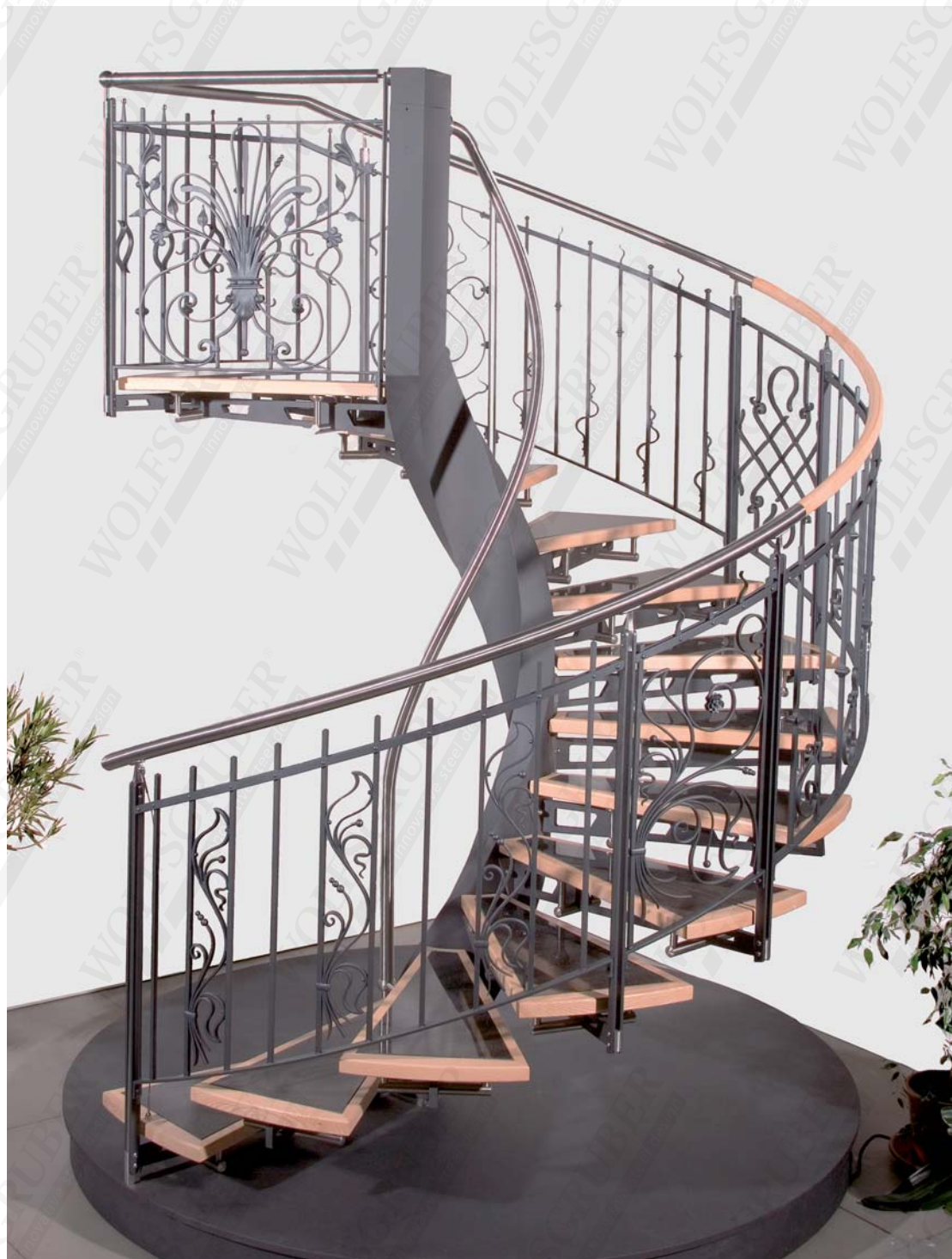

Serie
Trenta

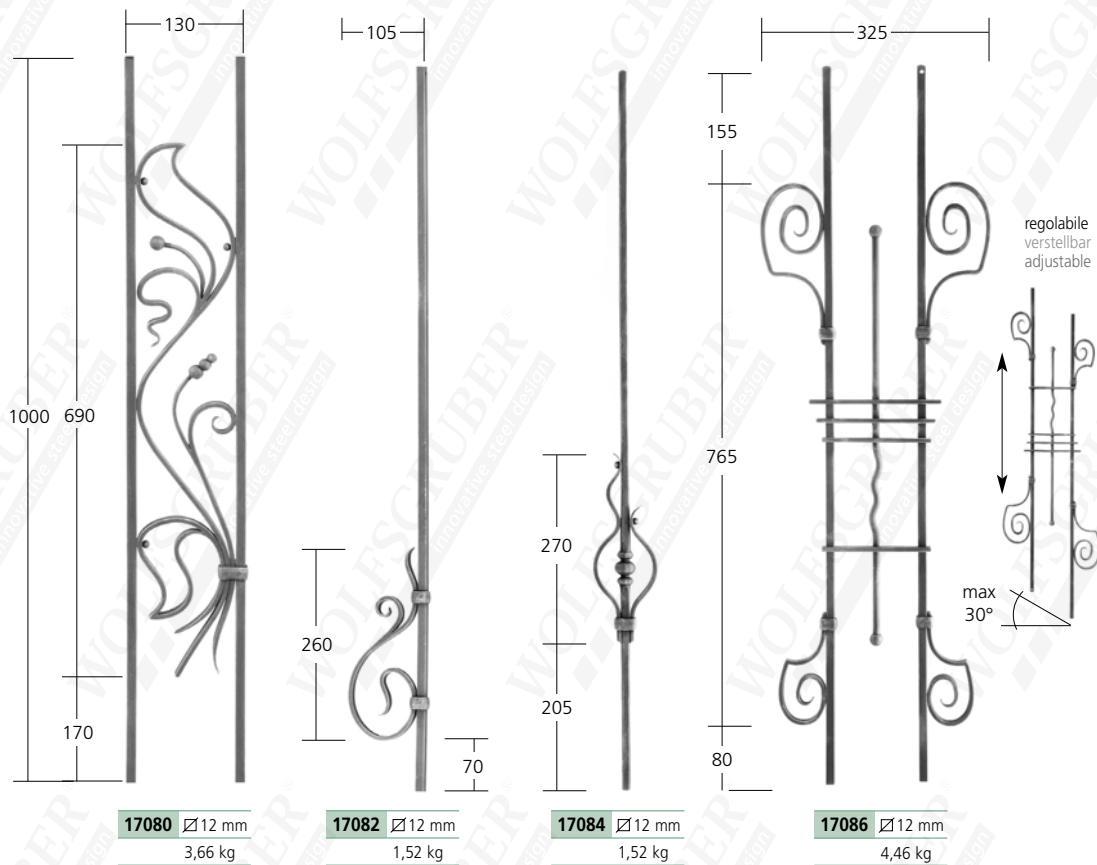

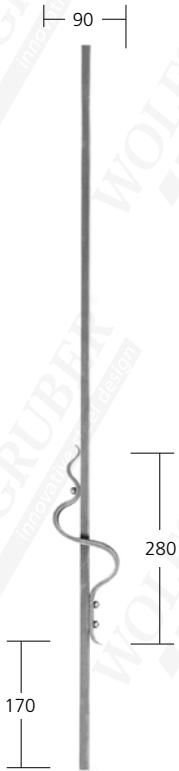

17090 $\varnothing 12$ mm
1,38 kg



17092 $\varnothing 12$ mm
1,20 kg



17094 $\varnothing 12$ mm
1,1 kg

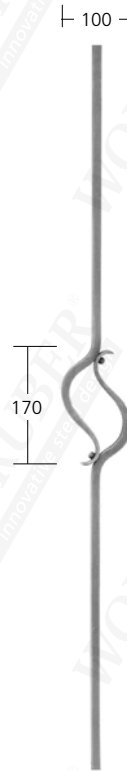

17096 $\varnothing 12$ mm
1,4 kg



17098 $\varnothing 12$ mm
1,5 kg



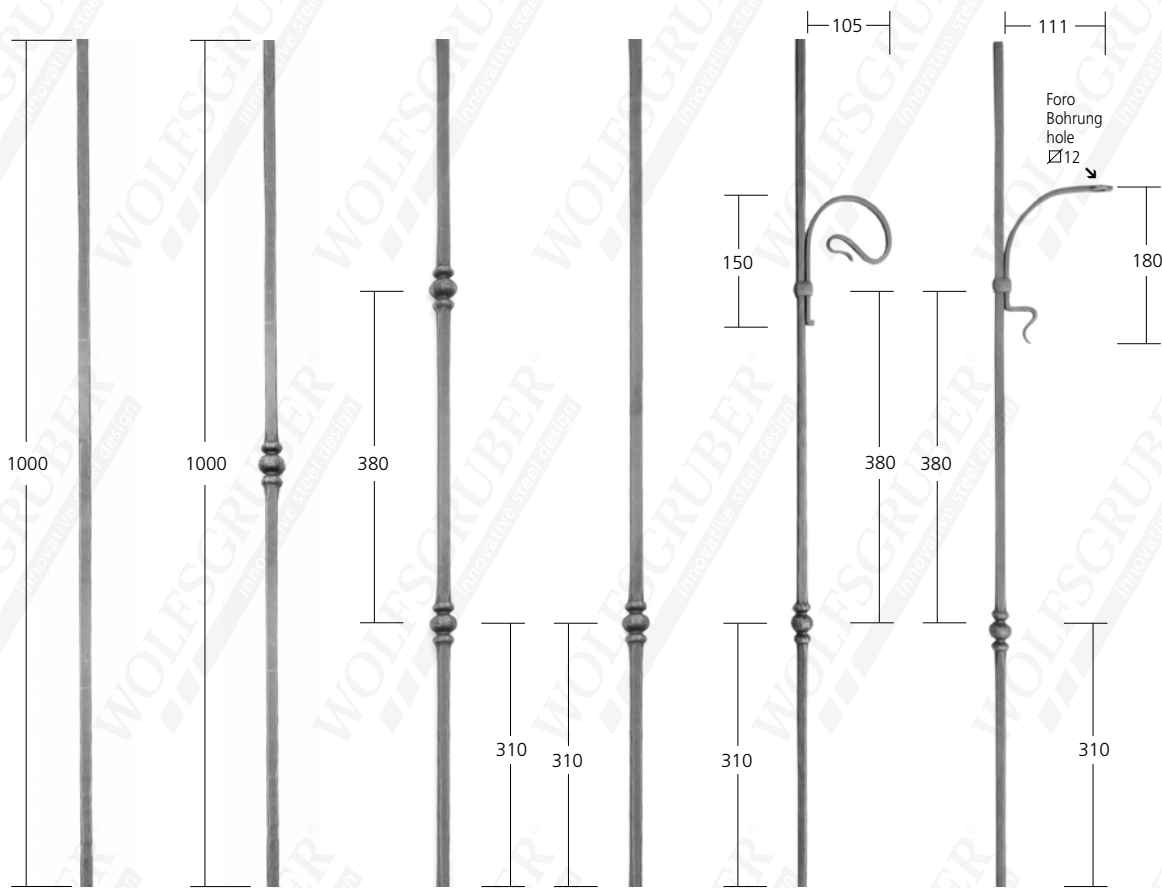

12464 Ø12 mm
1,00 kg

12465 Ø12 mm
1,10 kg

12466 Ø12 mm
1,18 kg

12467 Ø12 mm
1,10 kg

12468 Ø12 mm
1,28 kg

12469 Ø12 mm
1,25 kg



forgiato a mano · handgeschmiedet · hand forged

Linea
Trenta

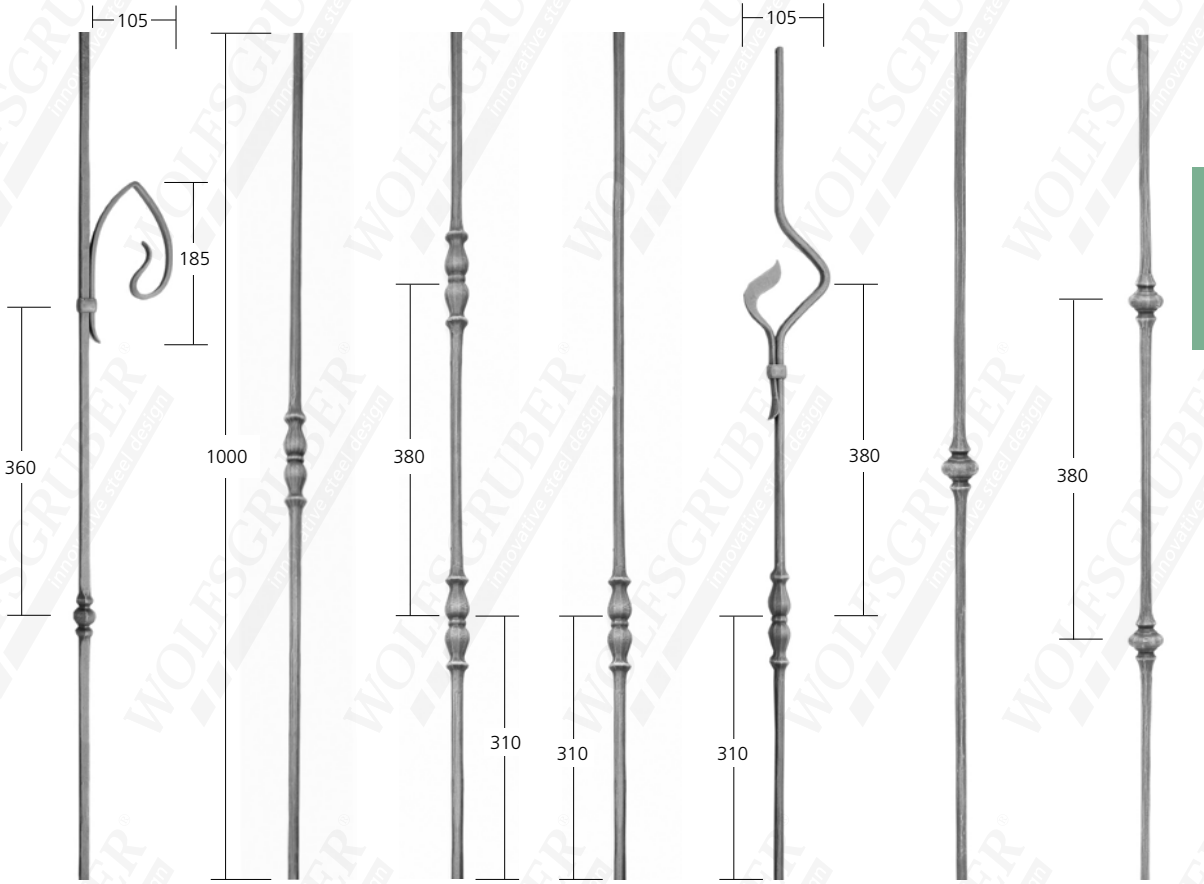

12470 Ø 12 mm
1,32 kg

12472 Ø 12 mm
1,05 kg

12473 Ø 12 mm
1,25 kg

12471 Ø 12 mm
1,05 kg

12476 Ø 12 mm
1,1 kg

12457 Ø 12 mm
1,00 kg

12458 Ø 12 mm
1,17 kg



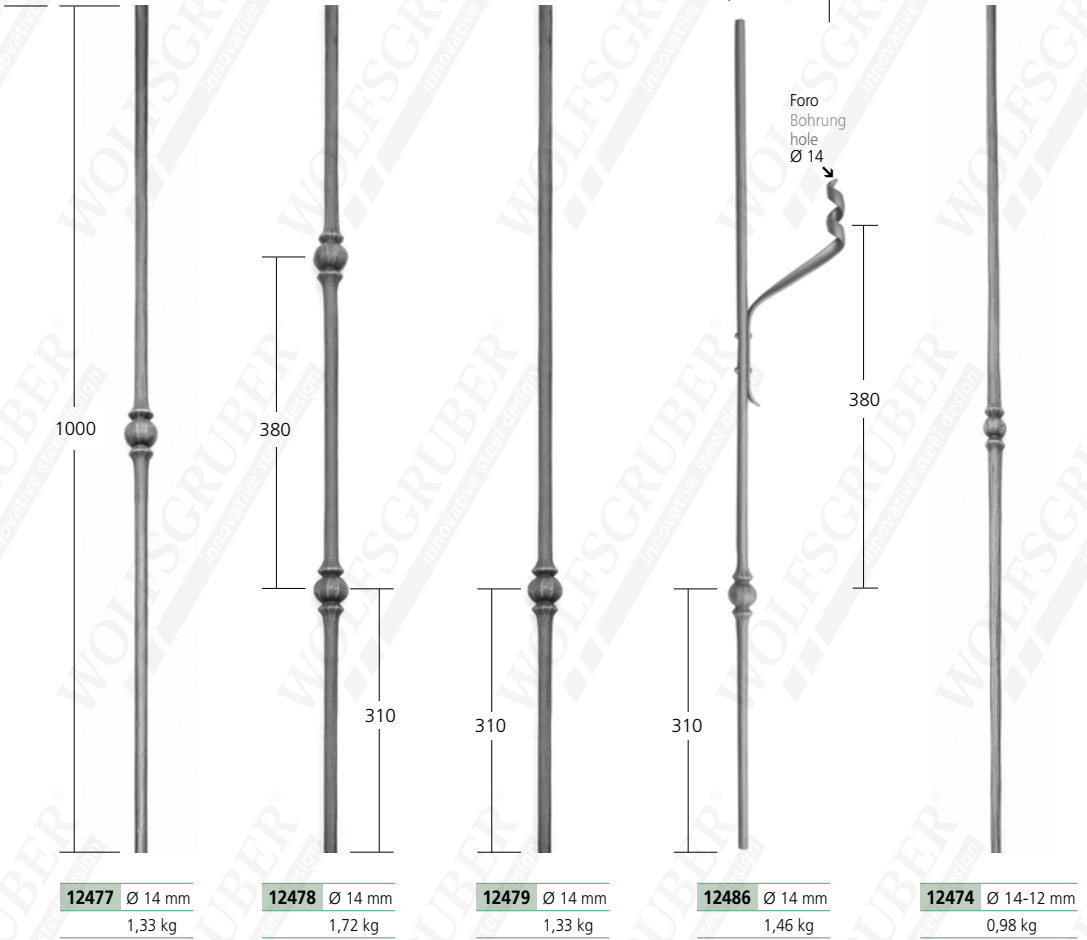

forgiato a mano · handgeschmiedet · hand forged

Trenta

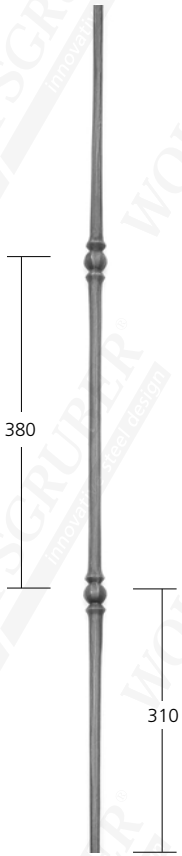

12475 Ø 14-12 mm
1,05 kg



12442 Ø 14-12 mm
0,91 kg



12480 Ø 12 mm
1,45 kg



12481 Ø 12 mm
1,80 kg



12482 Ø 12 mm
1,45 kg



12483 Ø 12 mm
1,74 kg

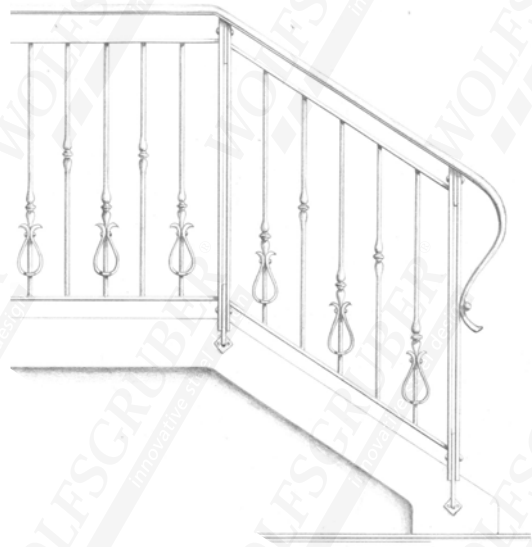

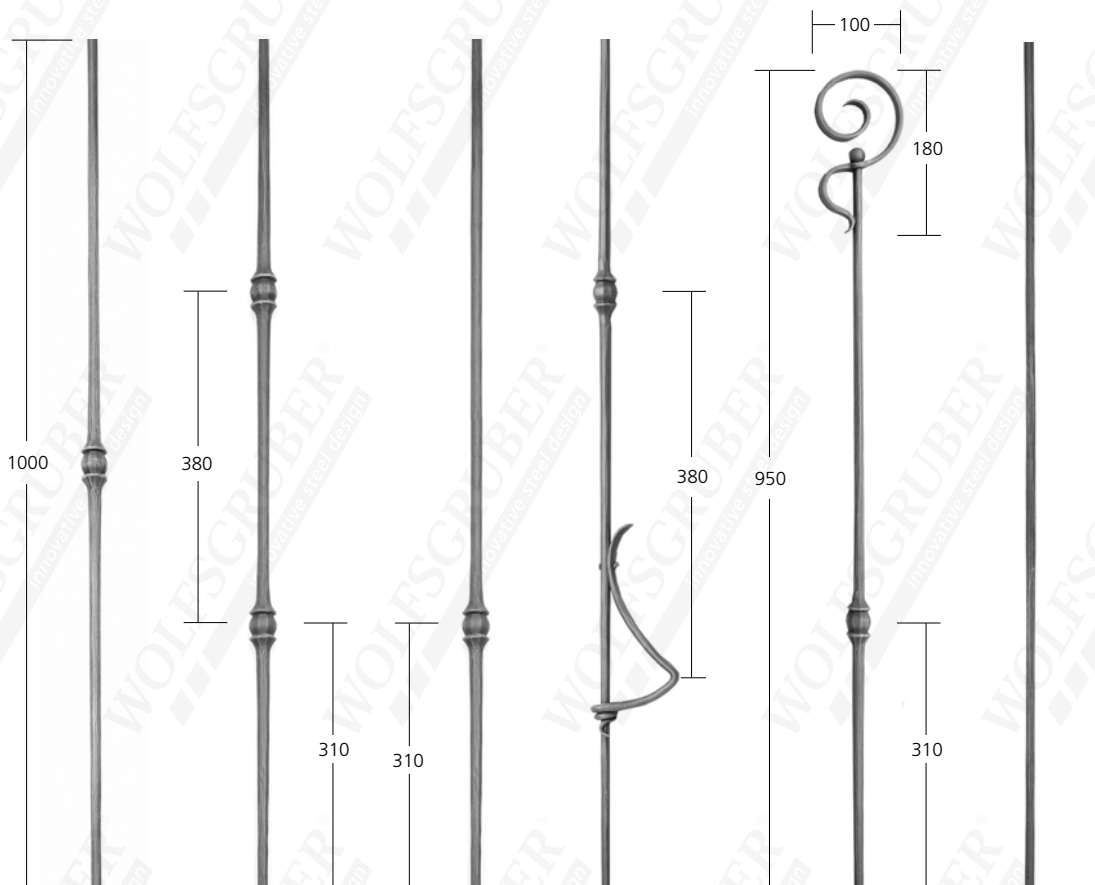

12450 Ø 12 mm
0,98 kg

12451 Ø 12 mm
1,15 kg

12452 Ø 12 mm
0,98 kg

12455 Ø 12 mm
1,18 kg

12456 Ø 12 mm
1,98 kg

12440 Ø 12 mm
0,84 kg





Serie
Trenta

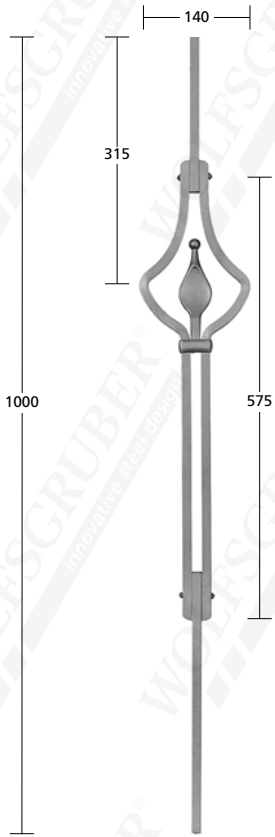

17110 $\varnothing 12$ mm

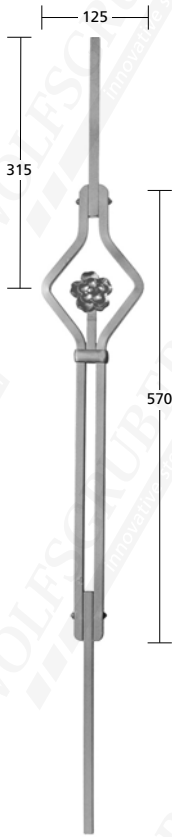

17112 $\varnothing 12$ mm

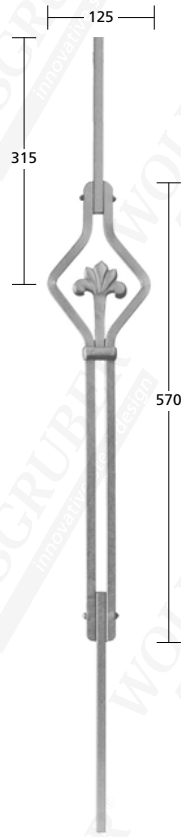

17114 $\varnothing 12$ mm

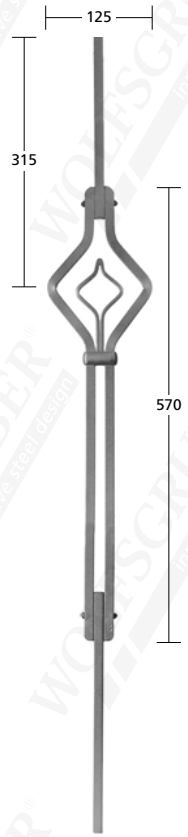

17116 $\varnothing 12$ mm



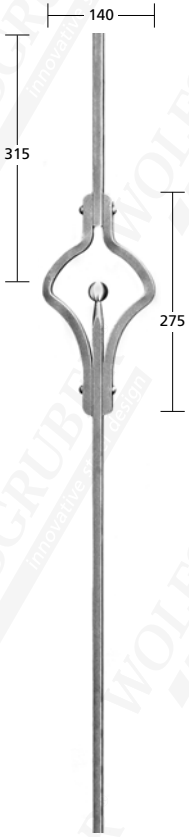

17117 $\varnothing 12$ mm

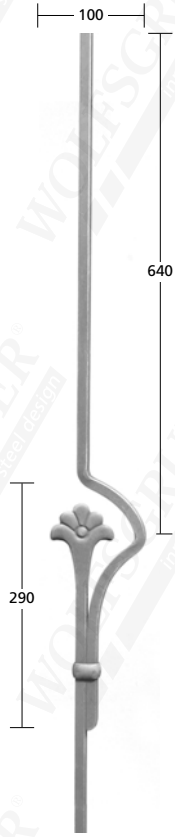

17119 $\varnothing 12$ mm

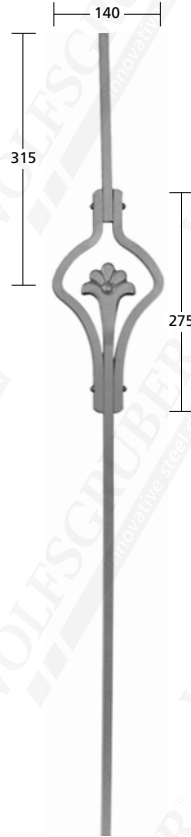

17120 $\varnothing 12$ mm

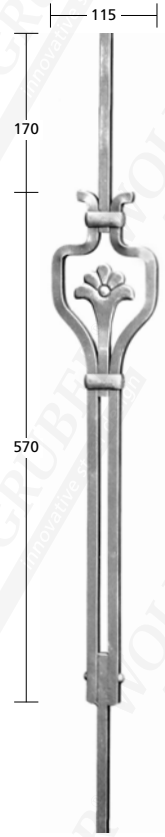

17121 $\varnothing 12$ mm



Serie
Trenta

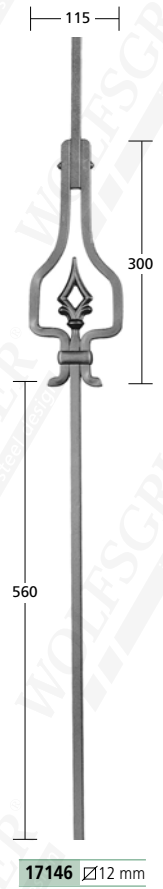
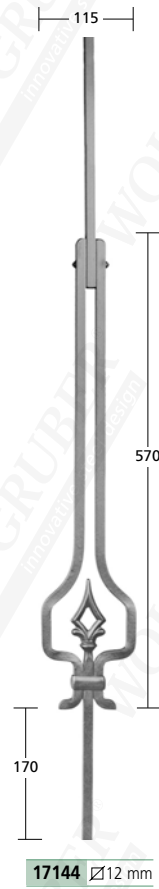
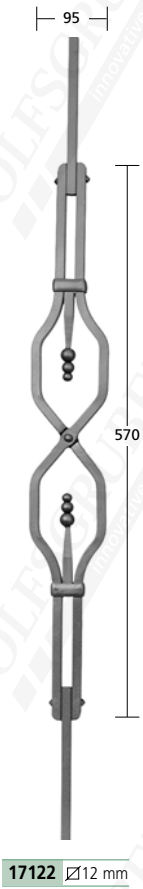
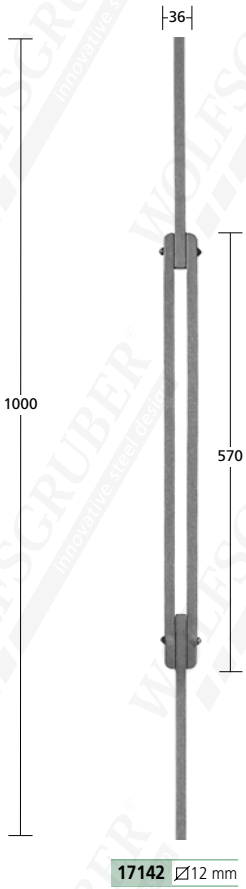

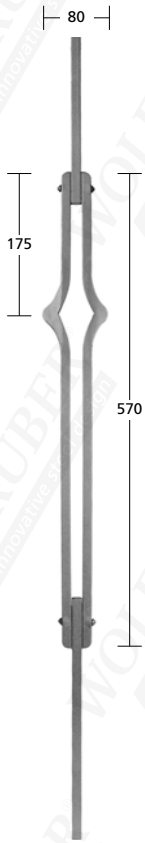

17140 $\varnothing 12$ mm

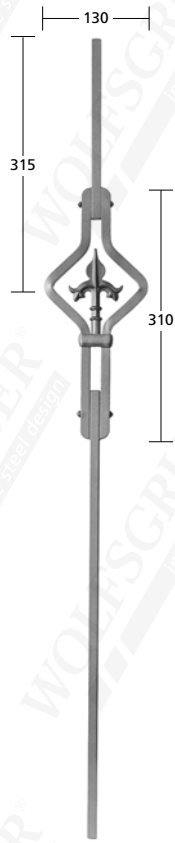

17118 $\varnothing 12$ mm



17128 $\varnothing 12$ mm

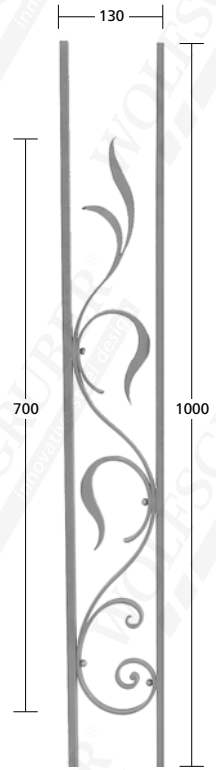

17131 $\varnothing 12$ mm





PALETTI - DESIGNSTÄBE - RODS

Serie **Trenta**



17150 Ø12 mm



17151 Ø12 mm



17154 Ø12 mm



17155 Ø12 mm



17156 Ø12 mm

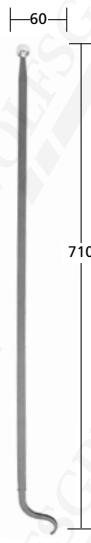

17160 Ø12 mm

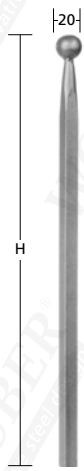

46050 H: 500 mm
46052 H: 1000 mm

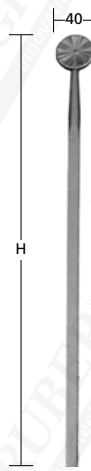

46055 H: 500 mm
46057 H: 1000 mm

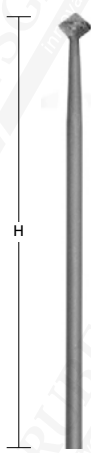

46038 H: 500 mm
46039 H: 1000 mm

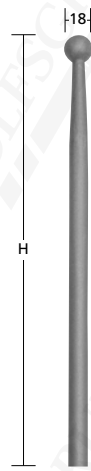

46035 H: 500 mm
46037 H: 1000 mm

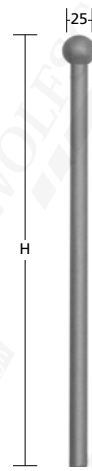

46060 H: 600 mm
46061 H: 1000 mm
46062 H: 1200 mm

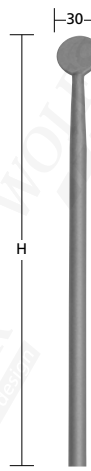

46040 H: 500 mm
46042 H: 1000 mm

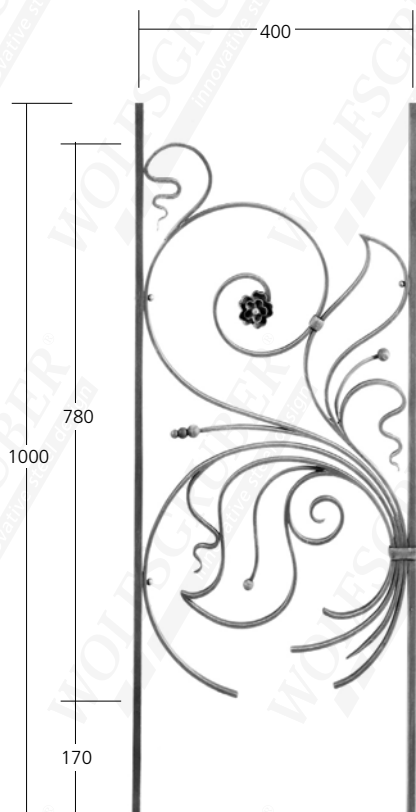

37005 Mat. 12x6 mm
5,72 kg

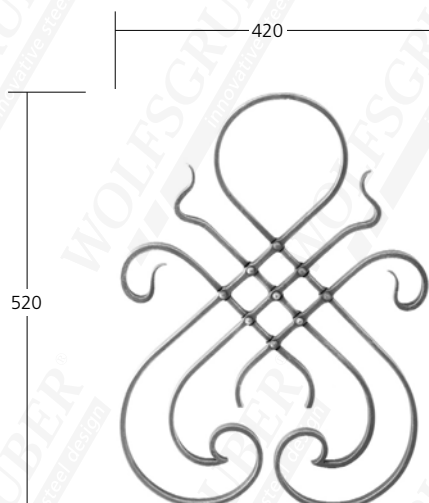

37008 Mat. 16x8 mm
4,0 kg



Serie
Trenta

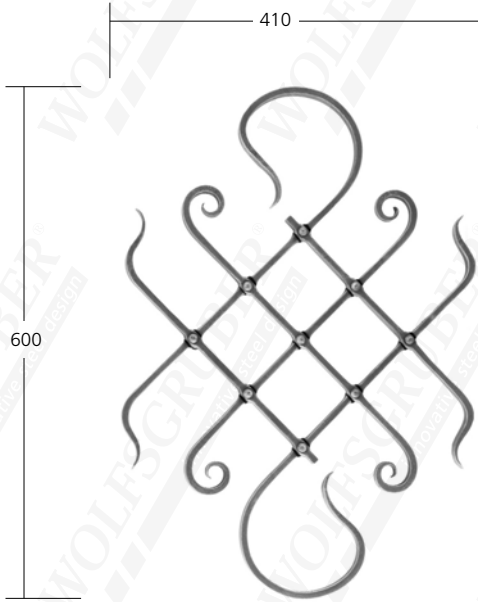

37010 Mat. 16x8 mm
3,22 kg

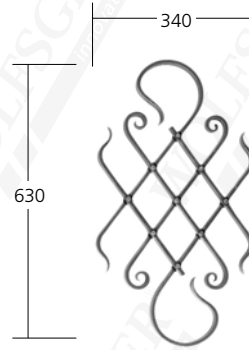

regolabile
verstellbar
adjustable

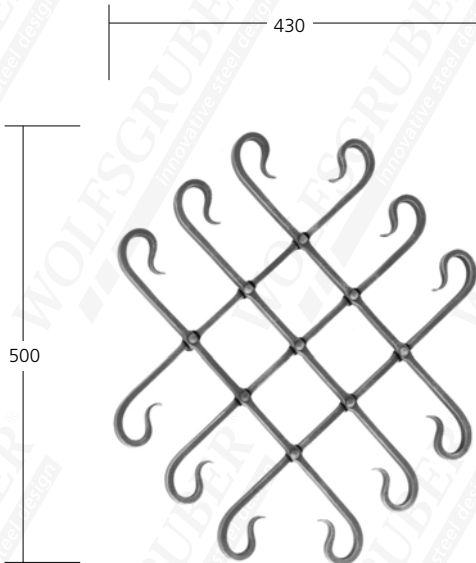

37012 Mat. 16x8 mm
3,34 kg

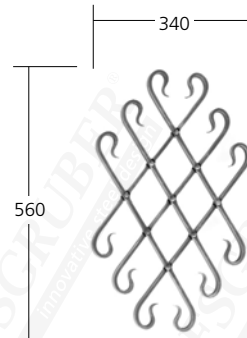

regolabile
verstellbar
adjustable



Usabile a due lati
Beidseitig verwendbar
both side usable

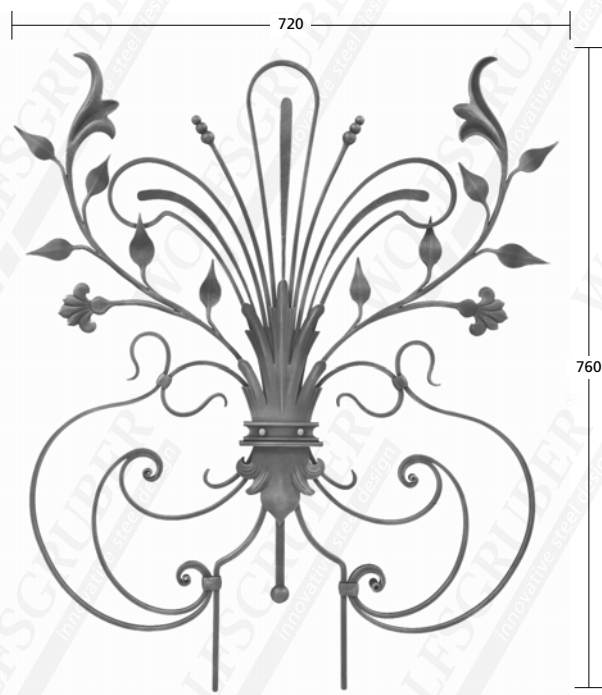

Serie
Trenta

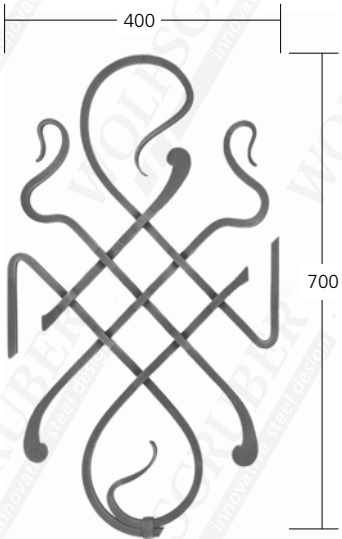

37030 ∅12 mm

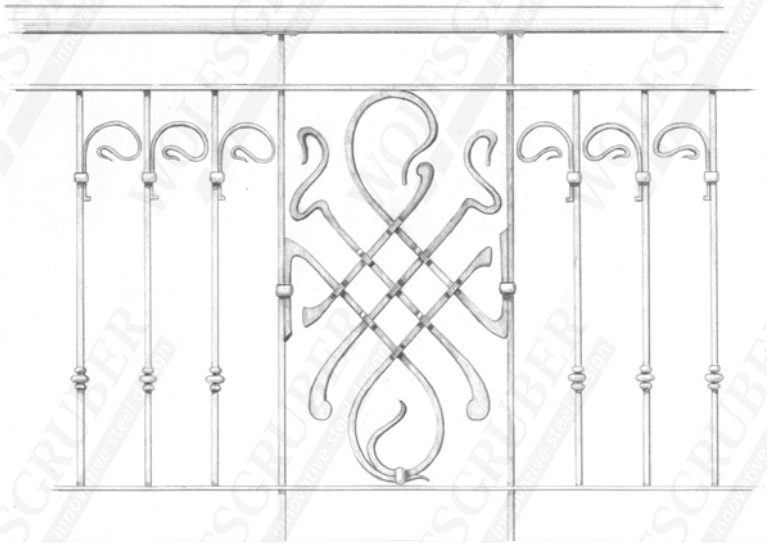

Usabile a due lati
Beidseitig verwendbar
both side usable

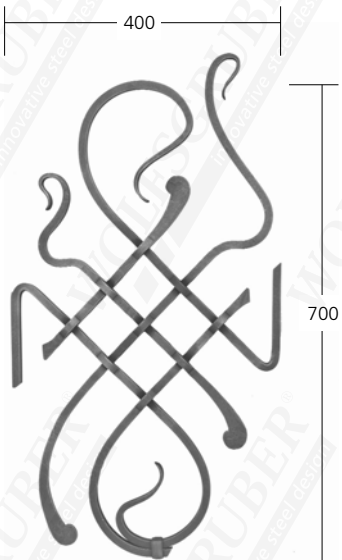

37032 ∅12 mm

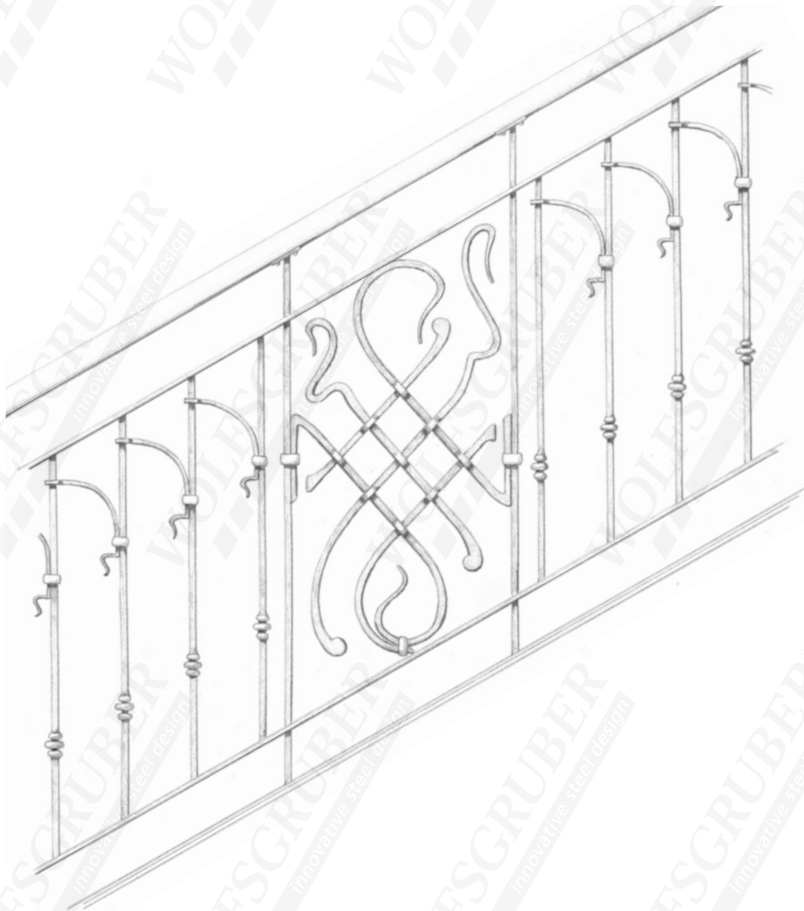

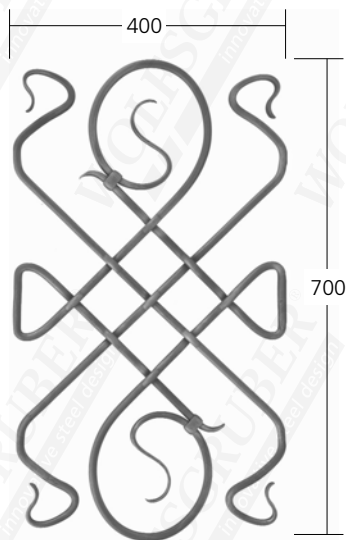

37050 Ø 12 mm

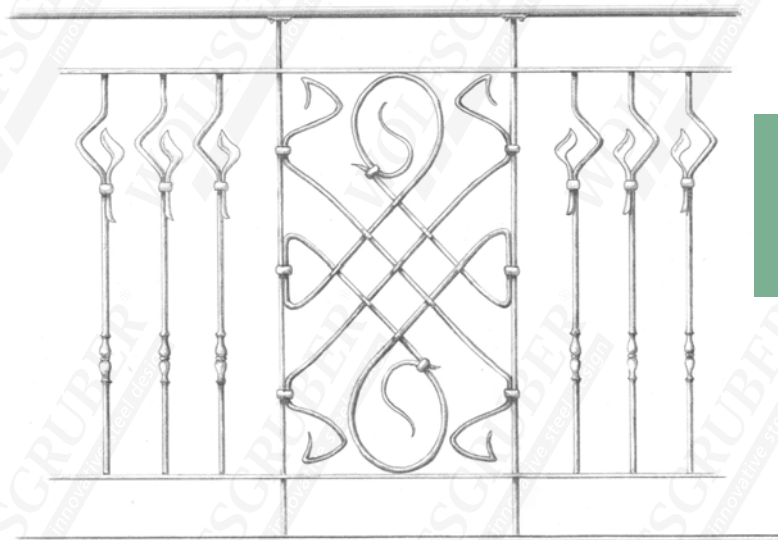

Usabile a due lati
Beidseitig verwendbar
both side usable

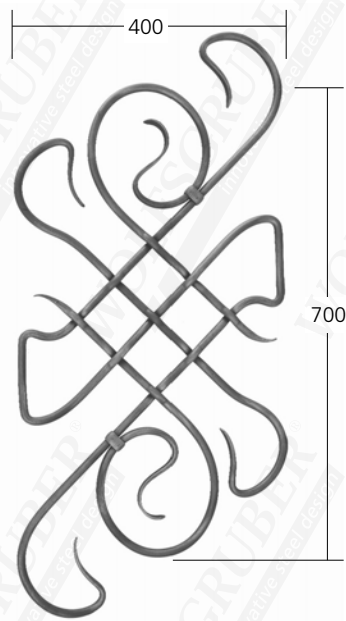

37052 Ø 12 mm

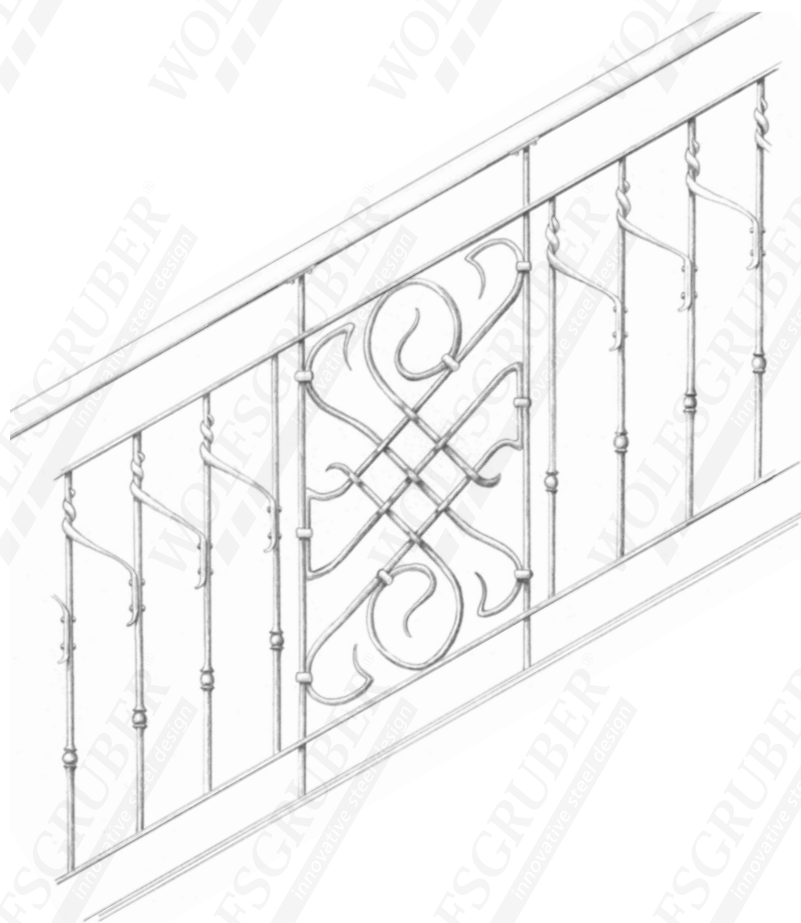

Serie
Trenta

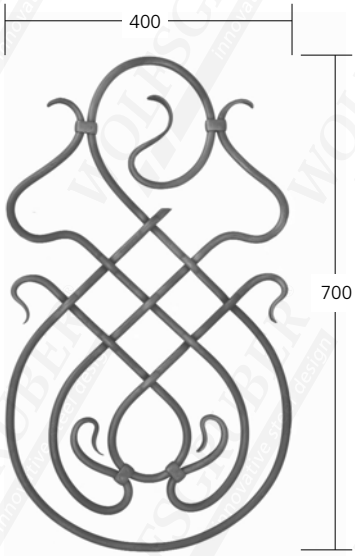

37040 Ø 12 mm

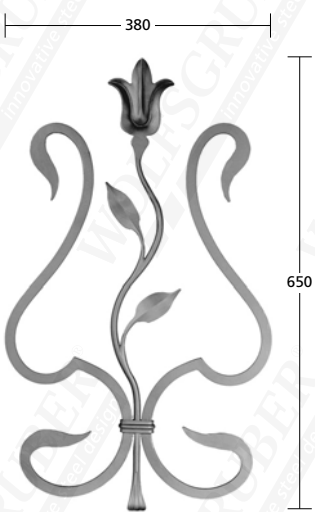
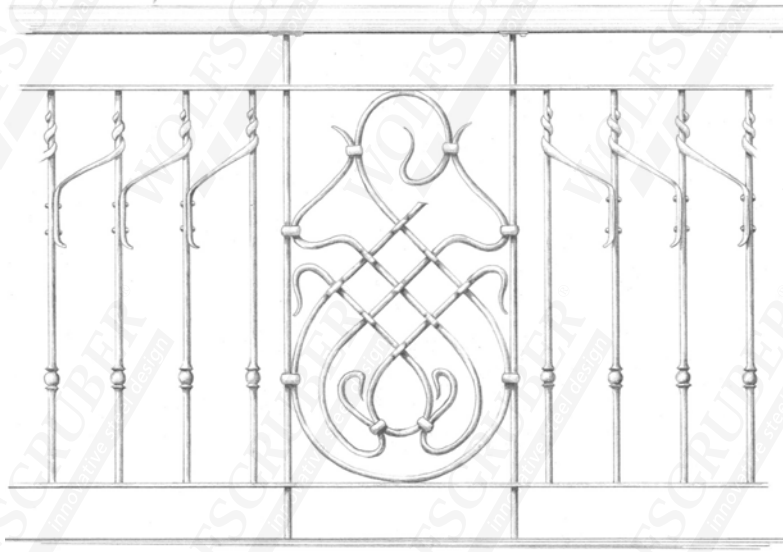

37110

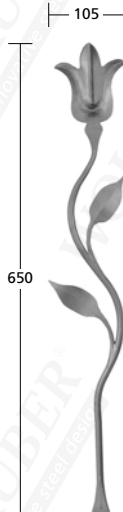

37114 Ø 10 mm



37115 12x6 mm



37116 12x6 mm

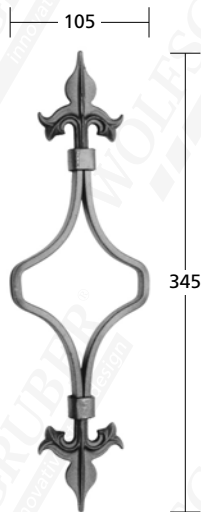

37130 12x6 mm

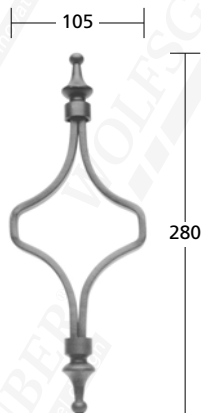

37132 12x6 mm



37140



37142

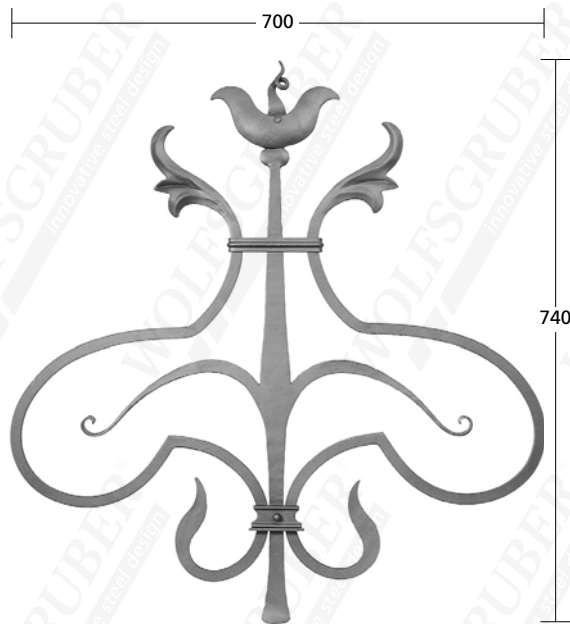

37120



12	12	12
x	x	x
6	12	6

 Fascetta · Bund

37152 16x3 mm

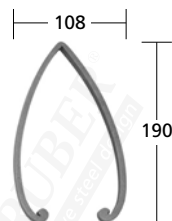

37150 12x6 mm



37125 12x6 mm

Serie
Trenta

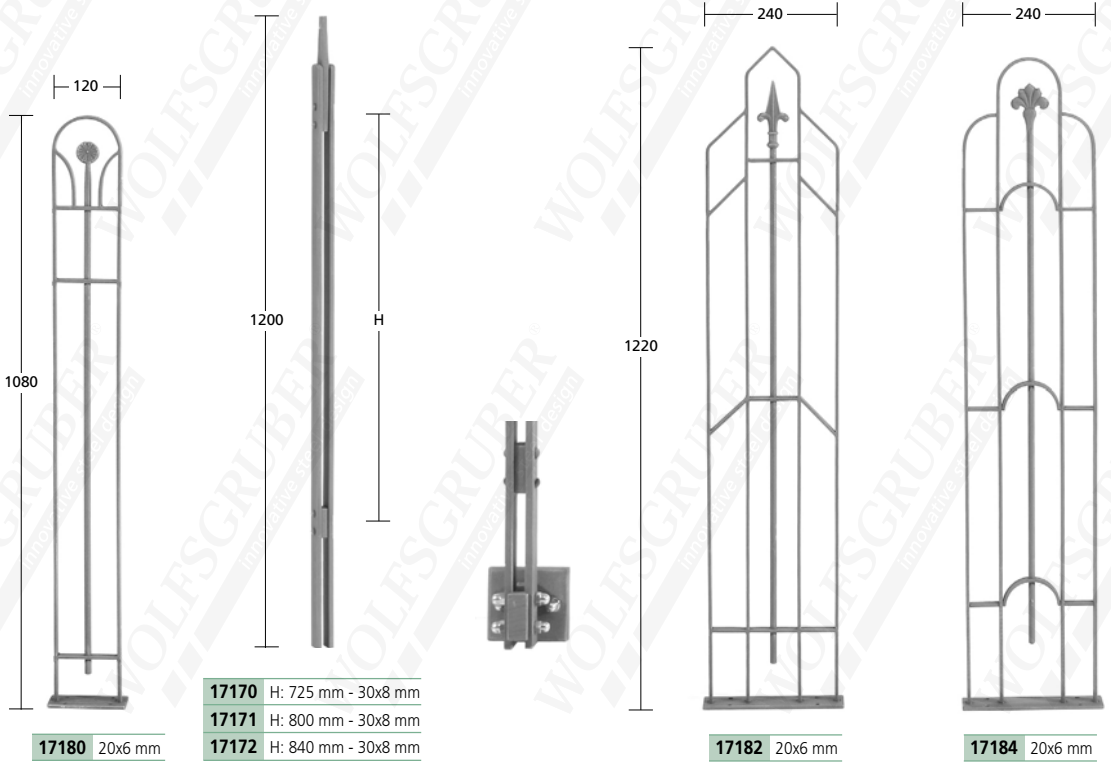

17175 80x80x10 mm



17176 100x100x10 mm

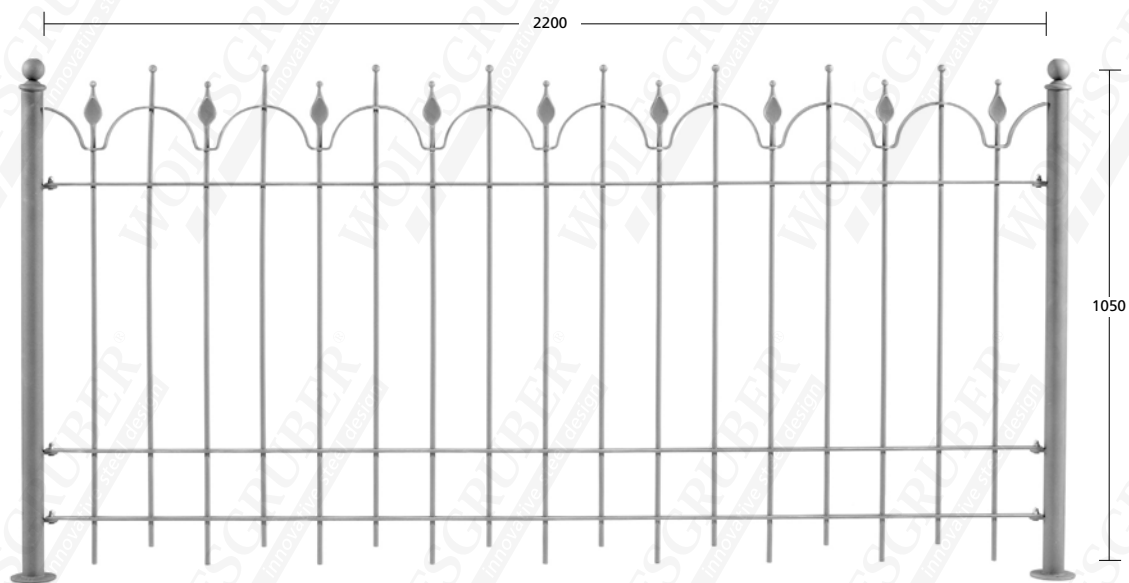

17310 ø 12 mm - 20x6 mm

Fornitura senza caposaldi - Anfangssteher nicht im Lieferumfang - Initial rods not in supply

Altre misure su richiesta - Sondergrößen auf Anfrage - other size on request

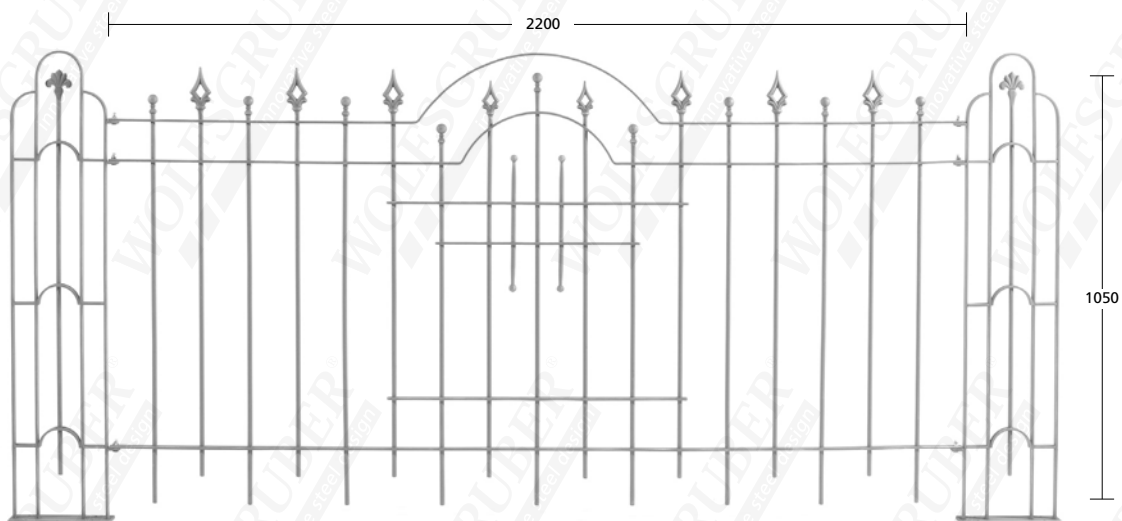

17320 ø 12 mm - 20x6 mm

Fornitura senza caposaldi - Anfangssteher nicht im Lieferumfang - Initial rods not in supply

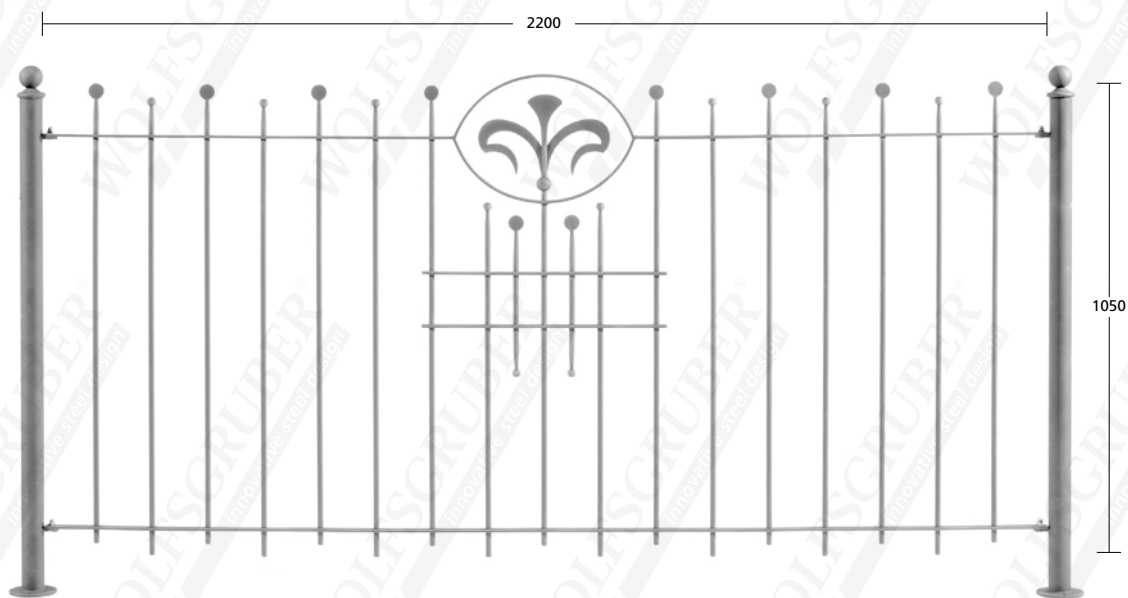

17330 ø 12mm - 20x6 mm

Fornitura senza caposaldi - Anfangssteher nicht im Lieferumfang - Initial rods not in supply

Altre misure su richiesta - Sondergrößen auf Anfrage - other size on request

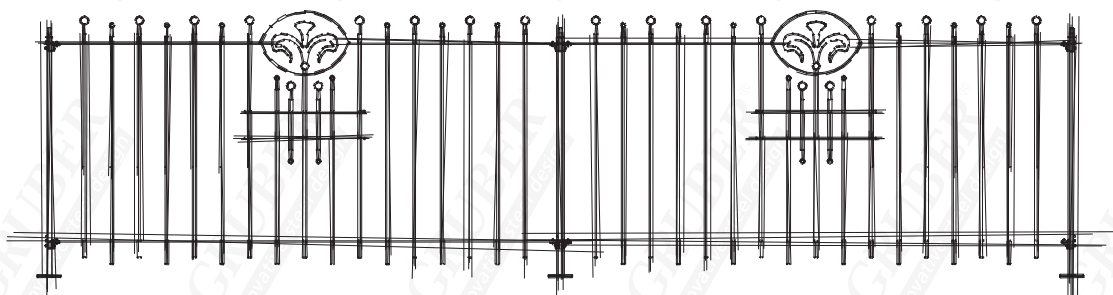

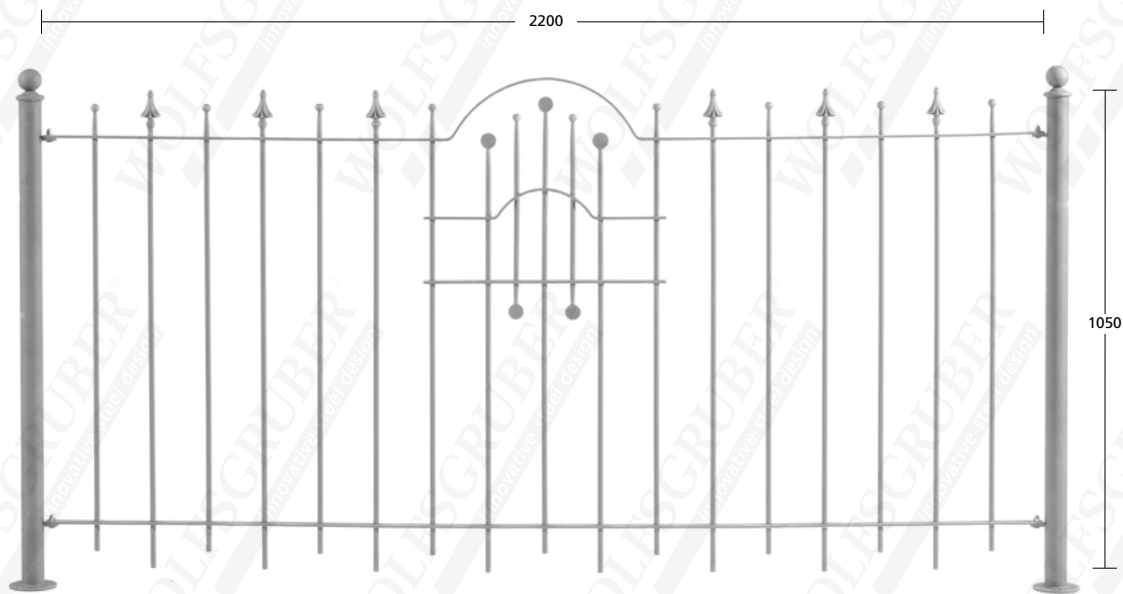

17340 \varnothing 12mm - 20x6 mm

Fornitura senza caposaldi - Anfangssteher nicht im Lieferumfang - Initial rods not in supply

Altre misure su richiesta - Sondergrößen auf Anfrage - other size on request

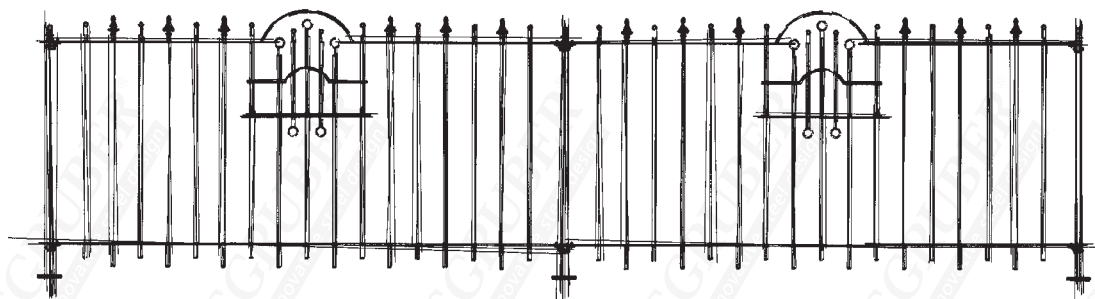

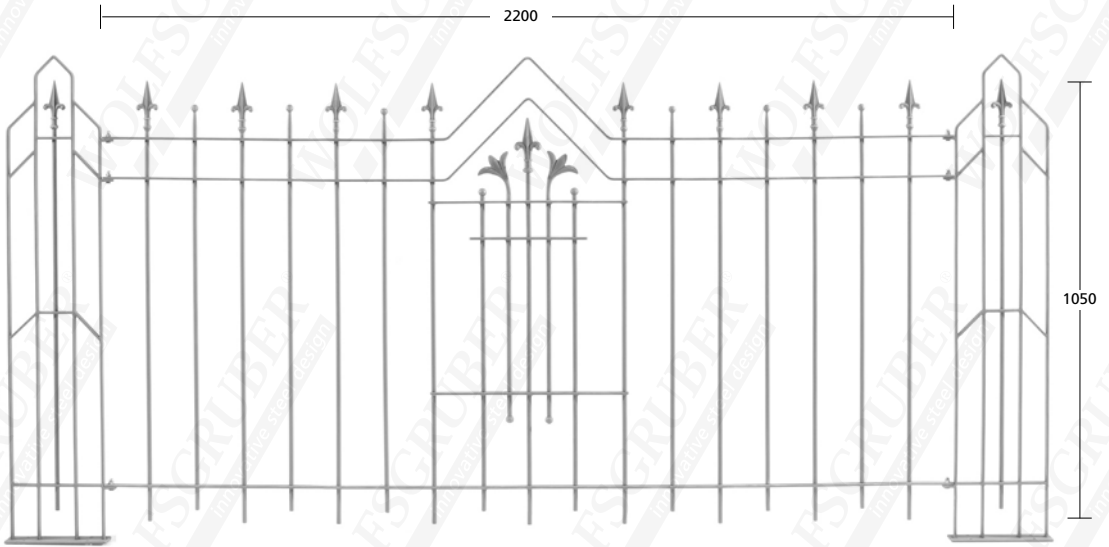

17350 ø 12mm - 20x6 mm

Fornitura senza caposaldi - Anfangssteher nicht im Lieferumfang - Initial rods not in supply

Altre misure su richiesta - Sondergrößen auf Anfrage - other size on request



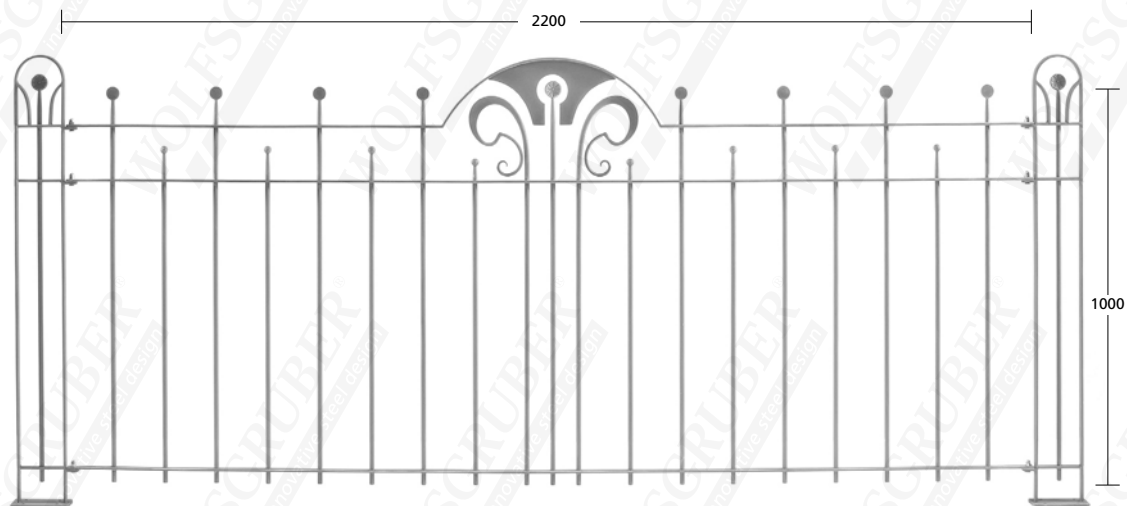

17360 ø 12mm - 20x6 mm

Fornitura senza caposaldi - Anfangssteher nicht im Lieferumfang - Initial rods not in supply

Altre misure su richiesta - Sondergrößen auf Anfrage - other size on request

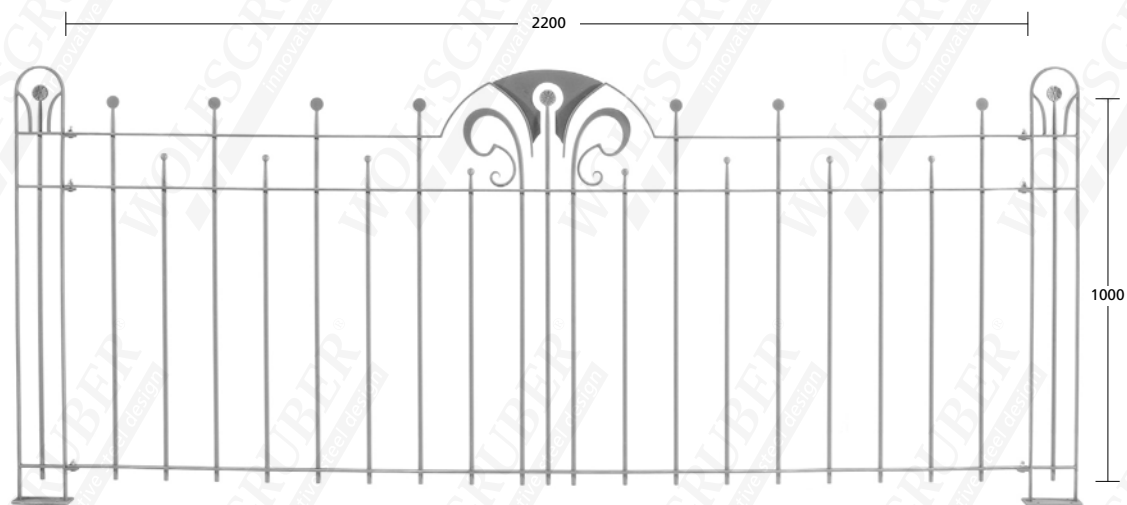

17370 ø 12mm - 20x6 mm

Fornitura senza caposaldi - Anfangssteher nicht im Lieferumfang - Initial rods not in supply

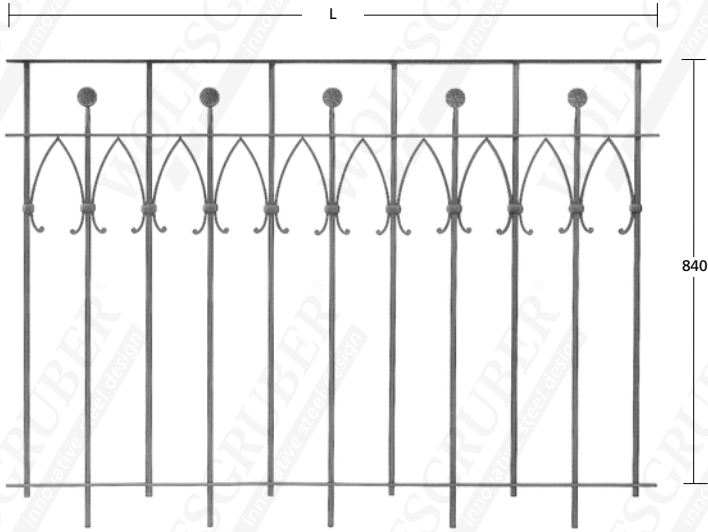

17410 \varnothing 12mm - 20x6 mm - L: 1320 mm

17415 \varnothing 12mm - 20x6 mm - L: 1800 mm

Altre misure su richiesta - Sondergrößen auf Anfrage - other size on request

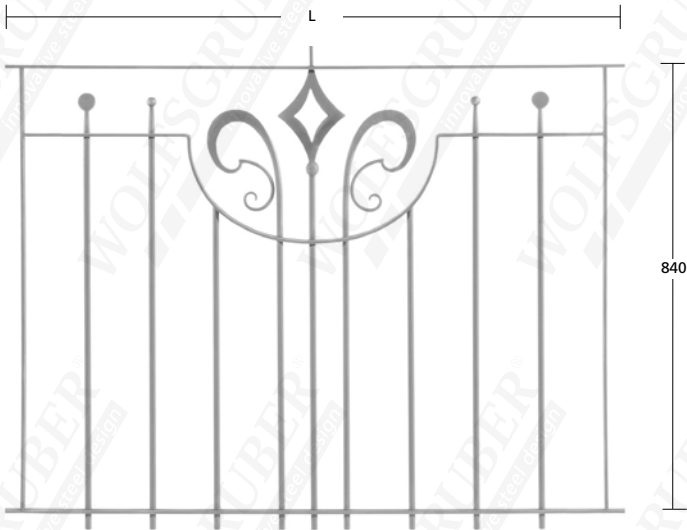

17420 \varnothing 12mm - 20x6 mm - L: 1320 mm

17425 \varnothing 12mm - 20x6 mm - L: 1800 mm

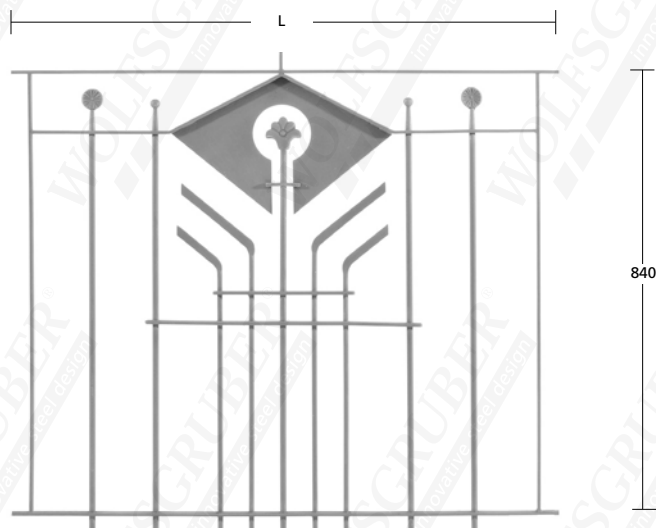

17430 \varnothing 12mm - 20x6 mm - L: 1320 mm

17435 \varnothing 12mm - 20x6 mm - L: 1800 mm

Altre misure su richiesta - Sondergrößen auf Anfrage - other size on request

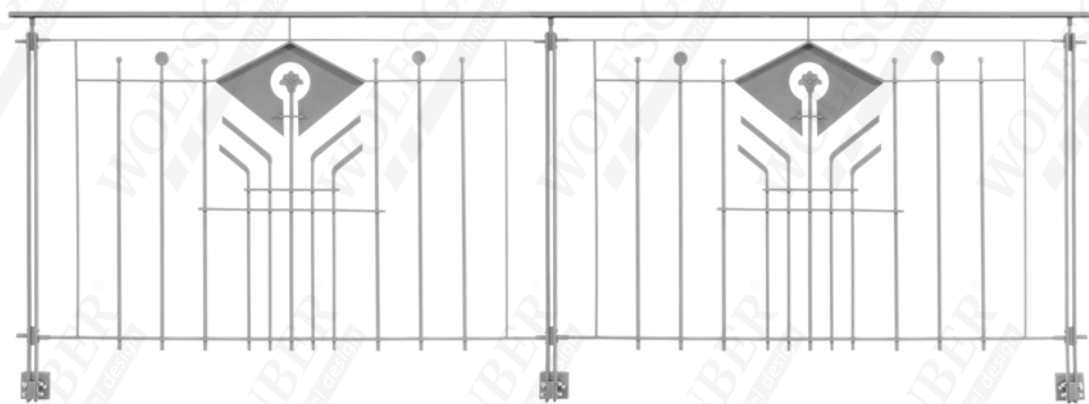

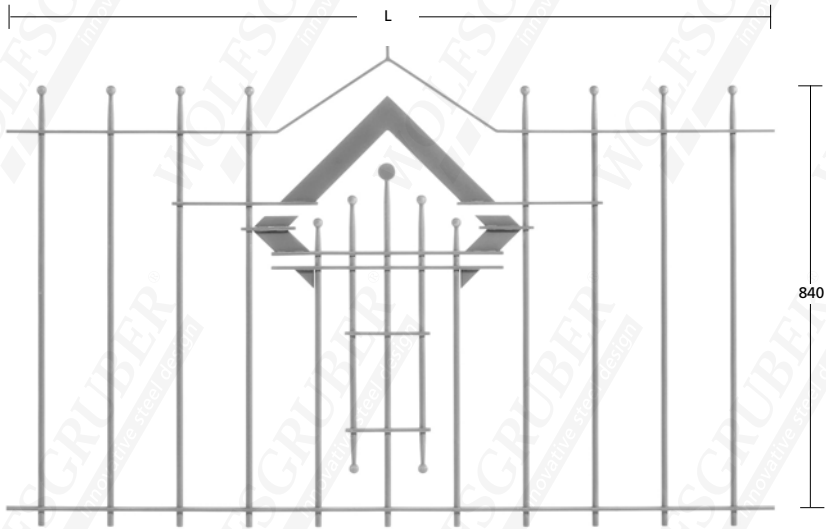

17440 \varnothing 12mm - 20x6 mm - L: 1440 mm

17445 \varnothing 12mm - 20x6 mm - L: 1920 mm

Altre misure su richiesta - Sondergrößen auf Anfrage - other size on request

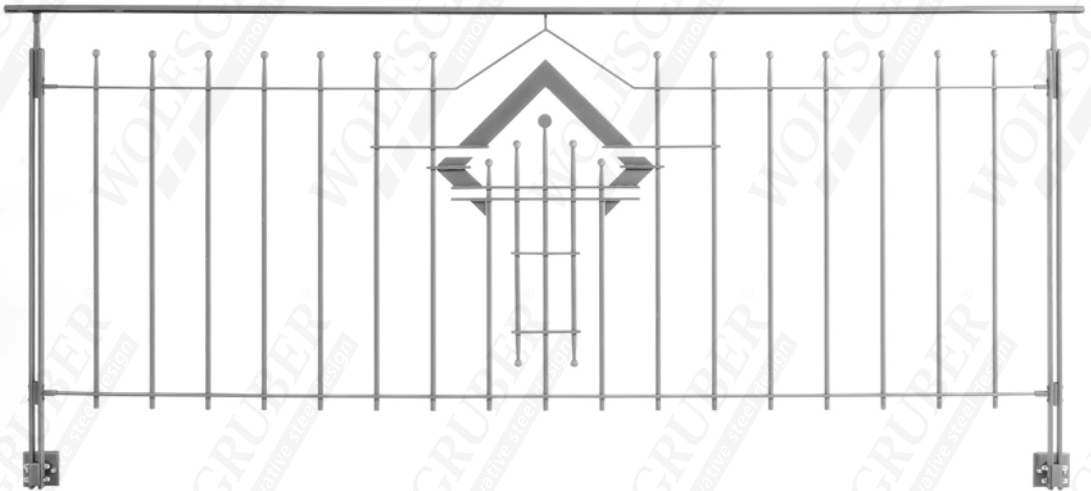

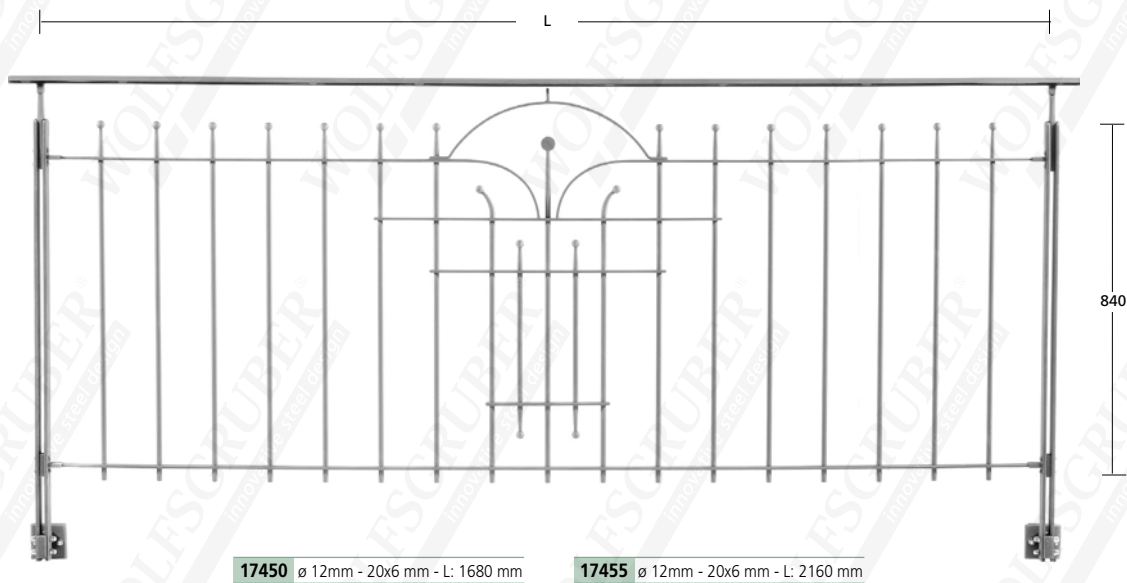

Fornitura senza caposaldi e corrimano - Anfangssteher und Handlauf nicht im Lieferumfang - Initial rods and handrail not in supply

Altre misure su richiesta - Sondergrößen auf Anfrage - other size on request

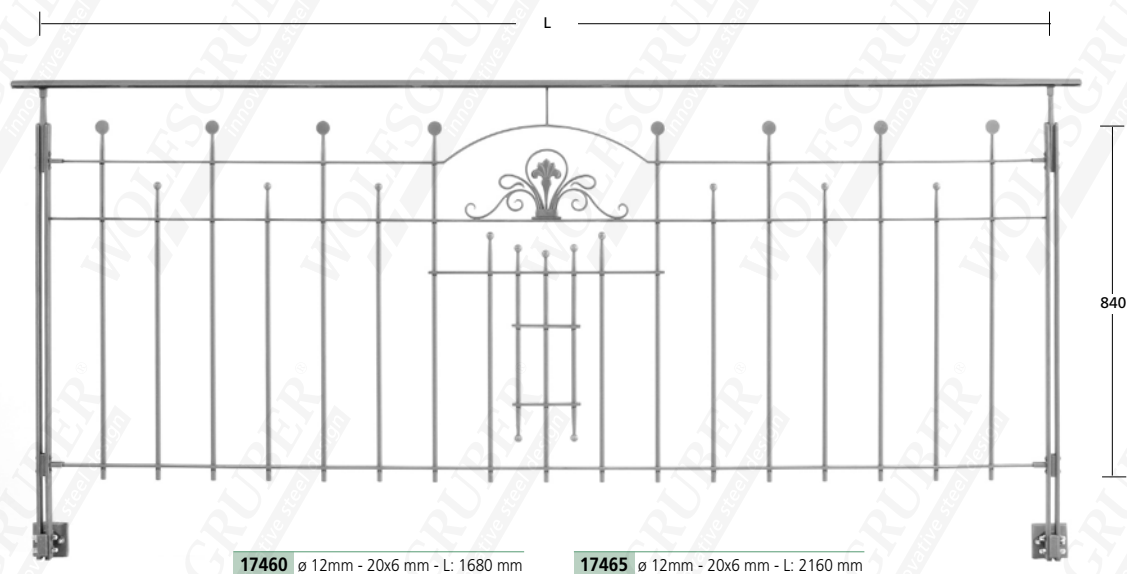

Fornitura senza caposaldi e corrimano - Anfangssteher und Handlauf nicht im Lieferumfang - Initial rods and handrail not in supply

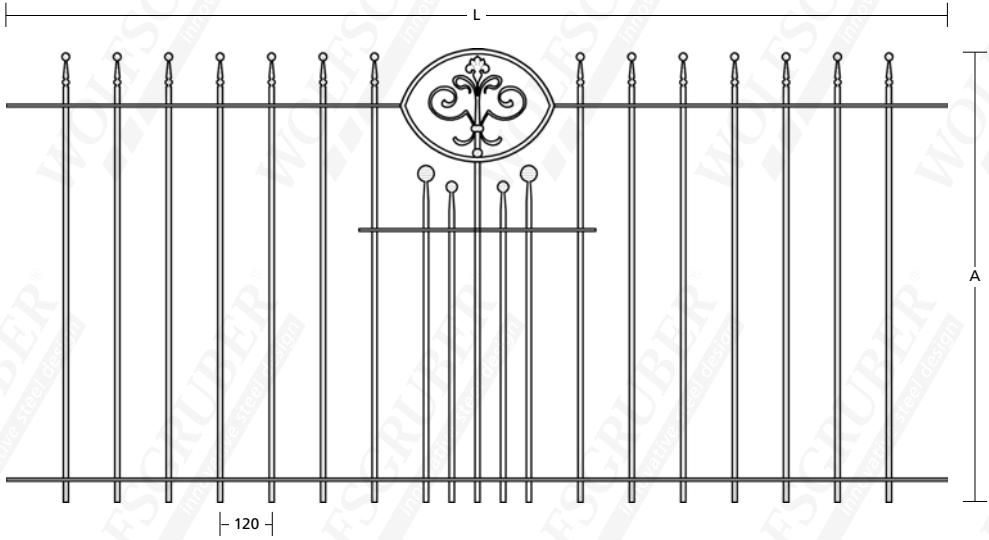

17600 25x8 l ø 12mm - L: 2200 - A: 700

17601 25x8 l ø 12mm - L: 2200 - A: 1000

Altre misure su richiesta - Sondergrößen auf Anfrage - other size on request

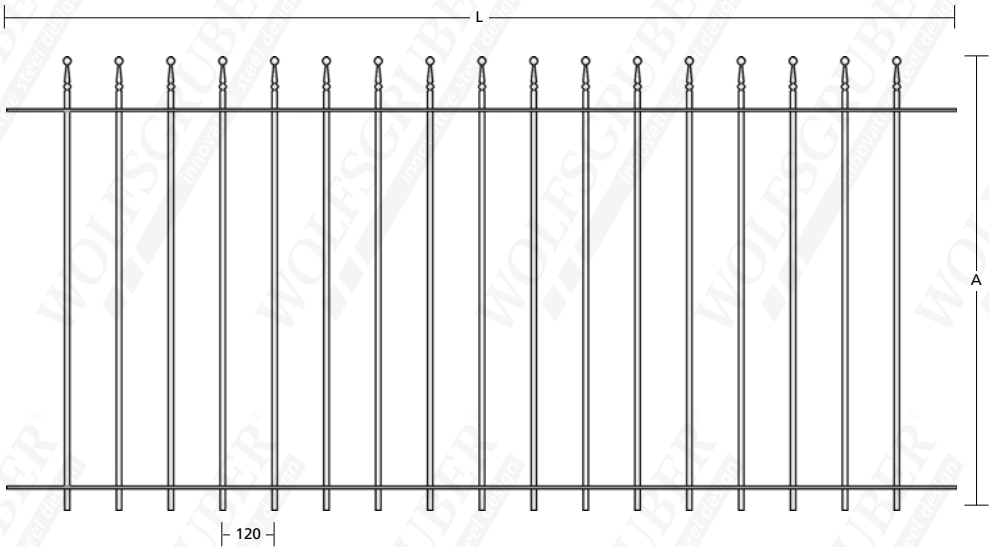

17603 25x8 l ø 12mm - L: 2200 - A: 700

17604 25x8 l ø 12mm - L: 2200 - A: 1000

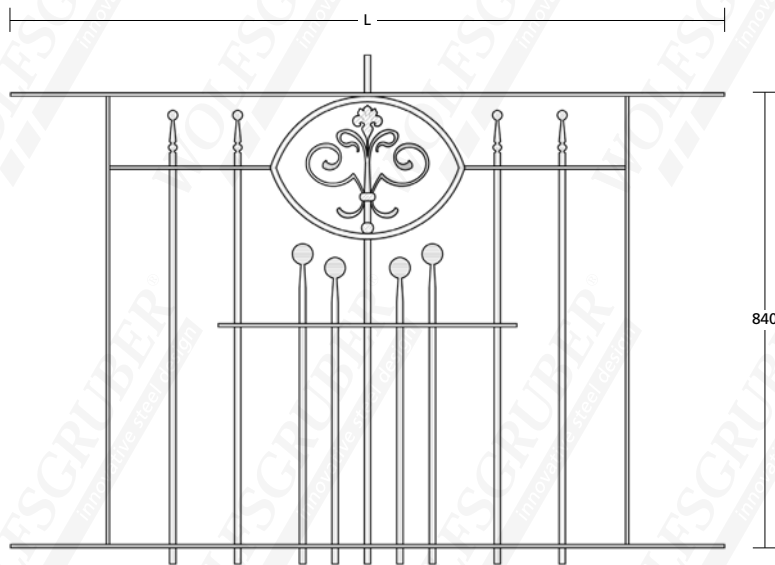

17500 25x8 | \varnothing 12mm - L: 1320

17501 25x8 | \varnothing 12mm - L: 1800

Altre misure su richiesta - Sondergrößen auf Anfrage - other size on request

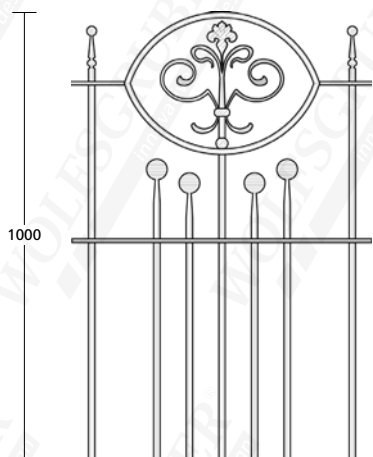

17500-E

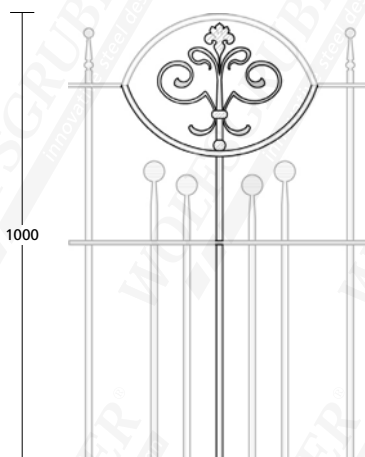

17500-S

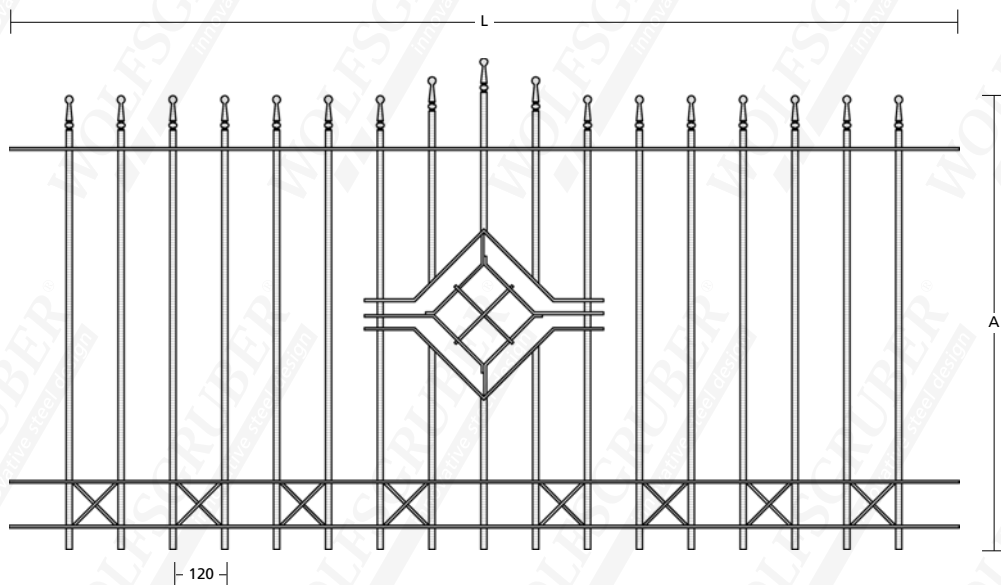

17605 25x8 | \varnothing 12mm - L: 2200 - A: 700

17606 25x8 | \varnothing 12mm - L: 2200 - A: 1000

Altre misure su richiesta - Sondergrößen auf Anfrage - other size on request

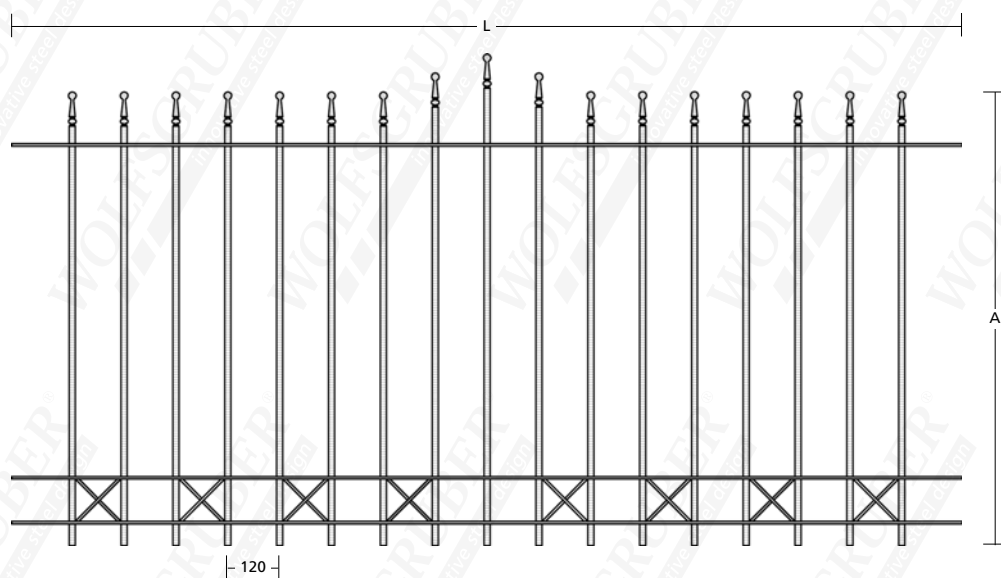

17608 25x8 | \varnothing 12mm - L: 2200 - A: 700

17609 25x8 | \varnothing 12mm - L: 2200 - A: 1000

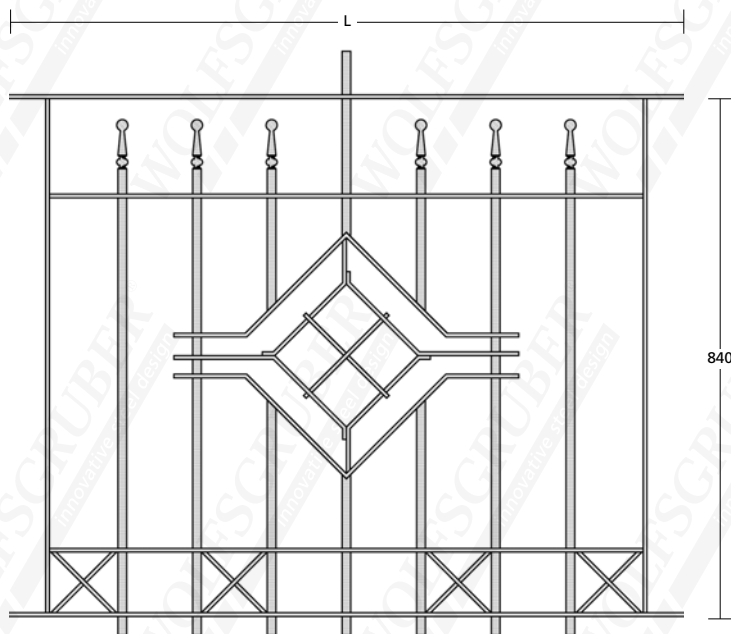
17505 25x8 | \varnothing 12mm - L: 132017506 25x8 | \varnothing 12mm - L: 1800

Altre misure su richiesta - Sondergrößen auf Anfrage - other size on request

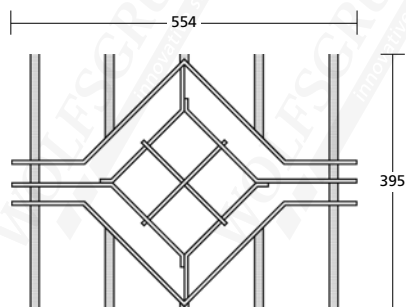

17505-E 12x6

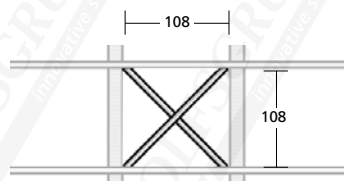

17505-K 12x6

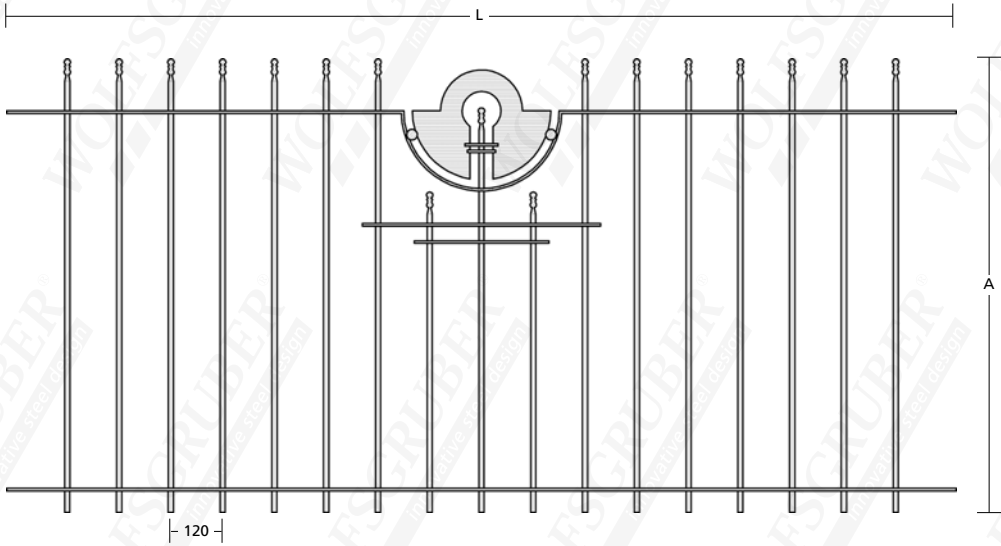

17610 25x8 l ø 12mm - L: 2200 - A: 700

17611 25x8 l ø 12mm - L: 2200 - A: 1000

Altre misure su richiesta - Sondergrößen auf Anfrage - other size on request

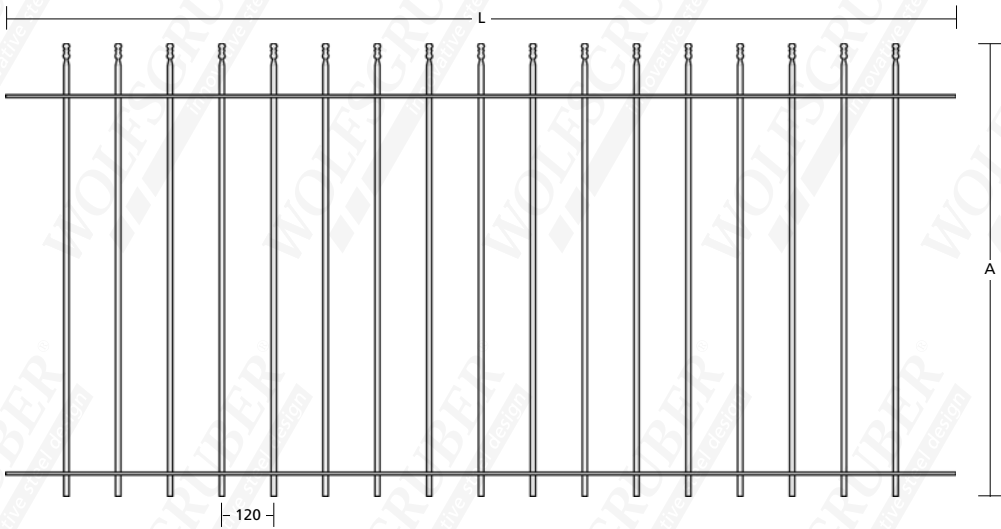

17613 25x8 l ø 12mm - L: 2200 - A: 700

17614 25x8 l ø 12mm - L: 2200 - A: 1000

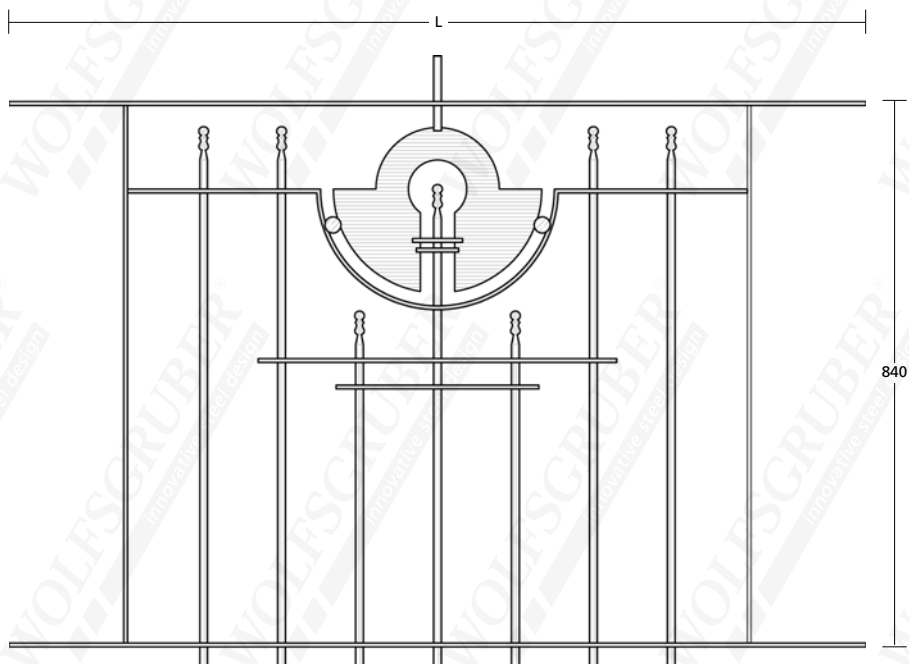
**17510** 25x8 | \varnothing 12mm - L: 1320**17511** 25x8 | \varnothing 12mm - L: 1800

Altre misure su richiesta - Sondergrößen auf Anfrage - other size on request

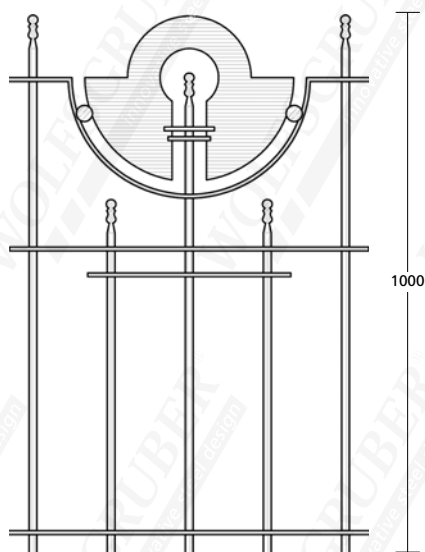
**17510-E**

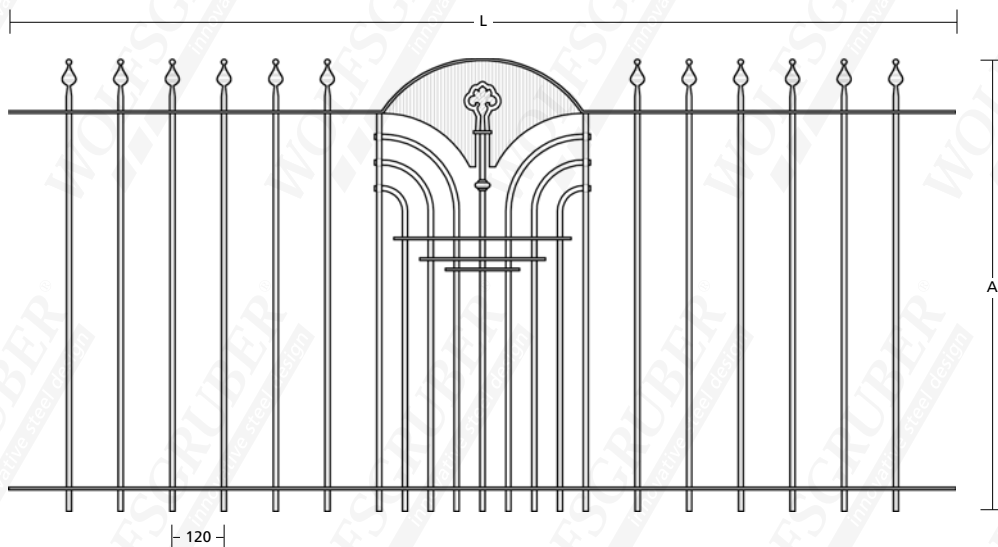

17615 25x8 | \varnothing 12mm - L: 2200 - A: 700

17616 25x8 | \varnothing 12mm - L: 2200 - A: 1000

Altre misure su richiesta - Sondergrößen auf Anfrage - other size on request

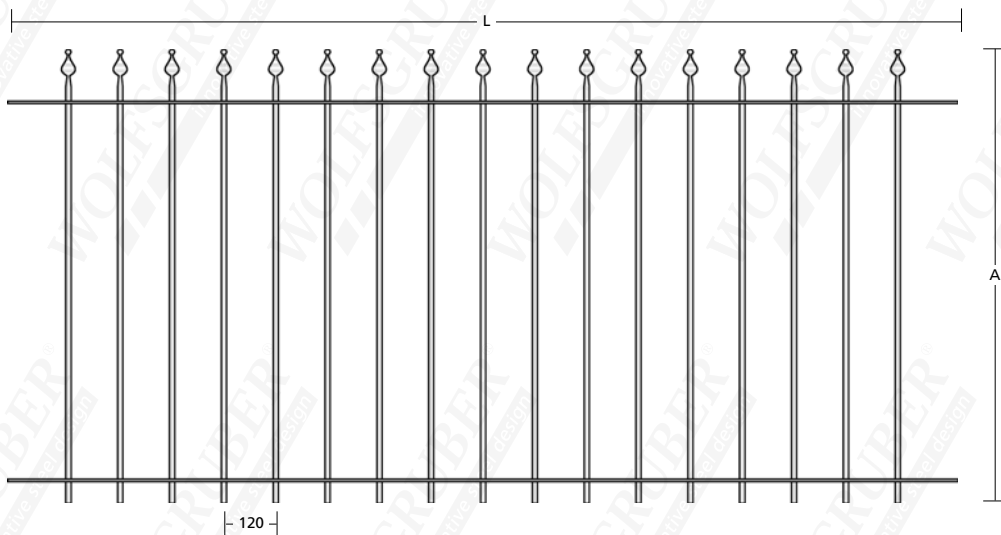

17618 25x8 | \varnothing 12mm - L: 2200 - A: 700

17619 25x8 | \varnothing 12mm - L: 2200 - A: 1000



Altre misure su richiesta - Sondergrößen auf Anfrage - other size on request

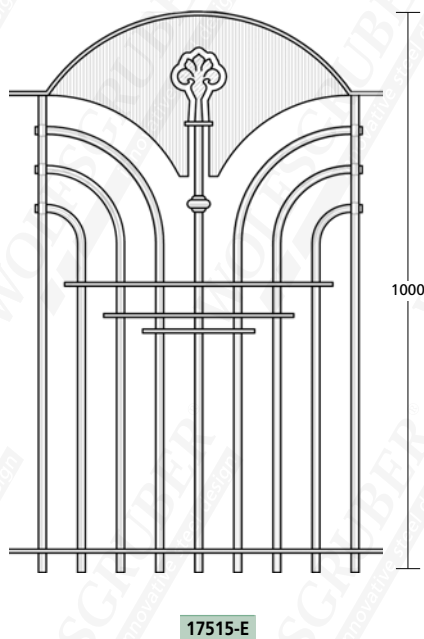

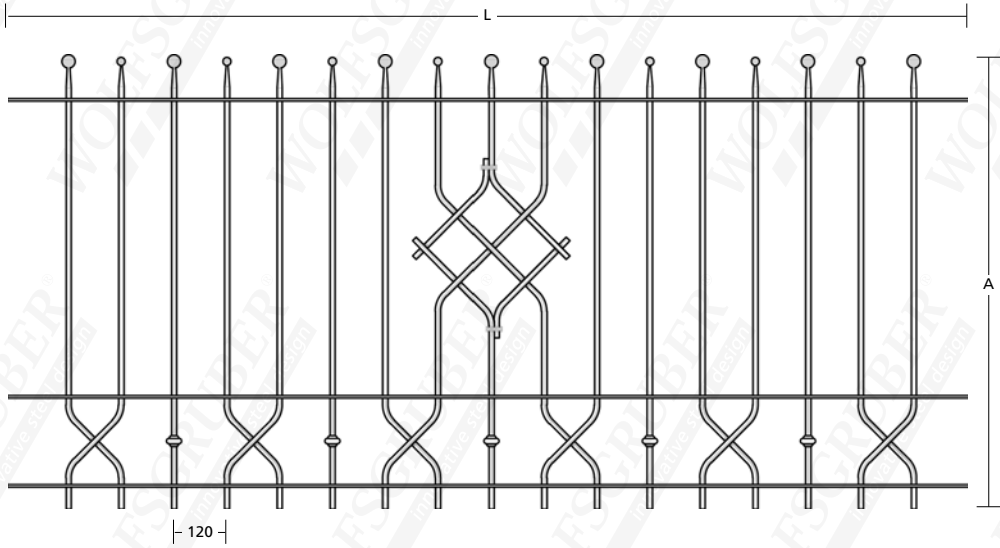

17620 25x8 l ø 12mm - L: 2200 - A: 1000

Altre misure su richiesta - Sondergrößen auf Anfrage - other size on request

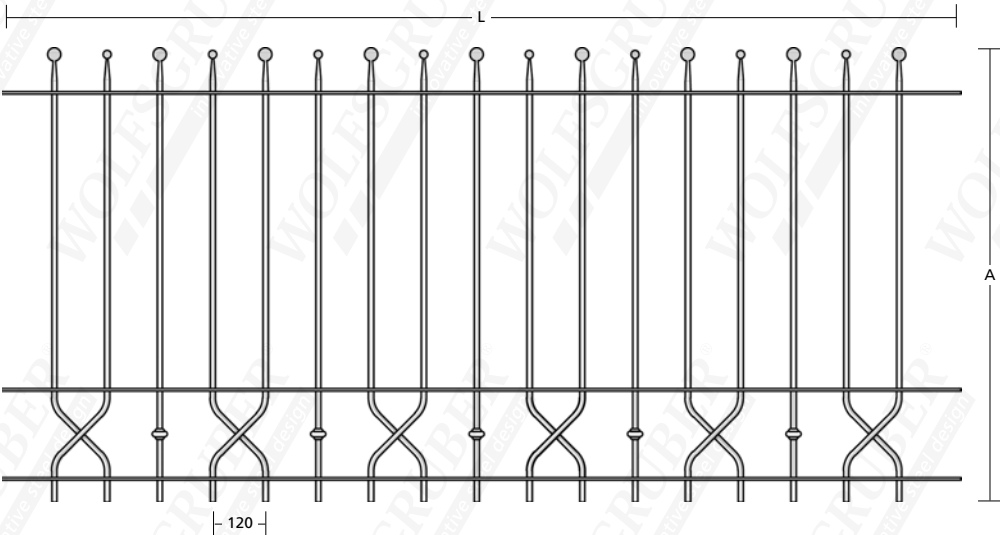

17623 25x8 l ø 12mm - L: 2200 - A: 700

17624 25x8 l ø 12mm - L: 2200 - A: 1000

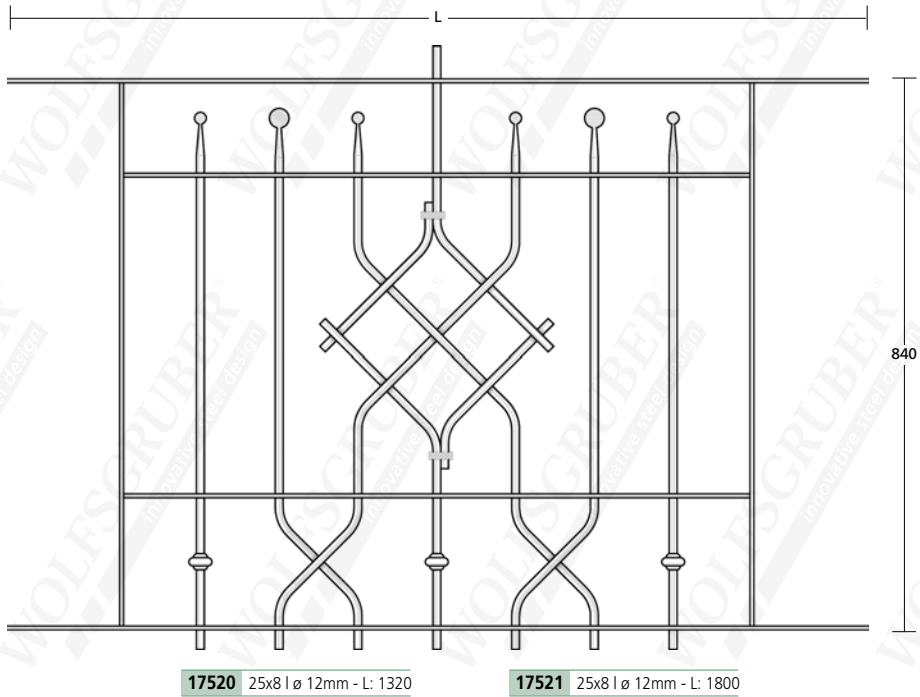

Altre misure su richiesta - Sondergrößen auf Anfrage - other size on request



PALETTI PER RECINZIONI - ZAUNSTÄBE - STAKES FOR FENCE

Serie
Trenta



Altre misure su richiesta - Sondergrößen auf Anfrage - other size on request

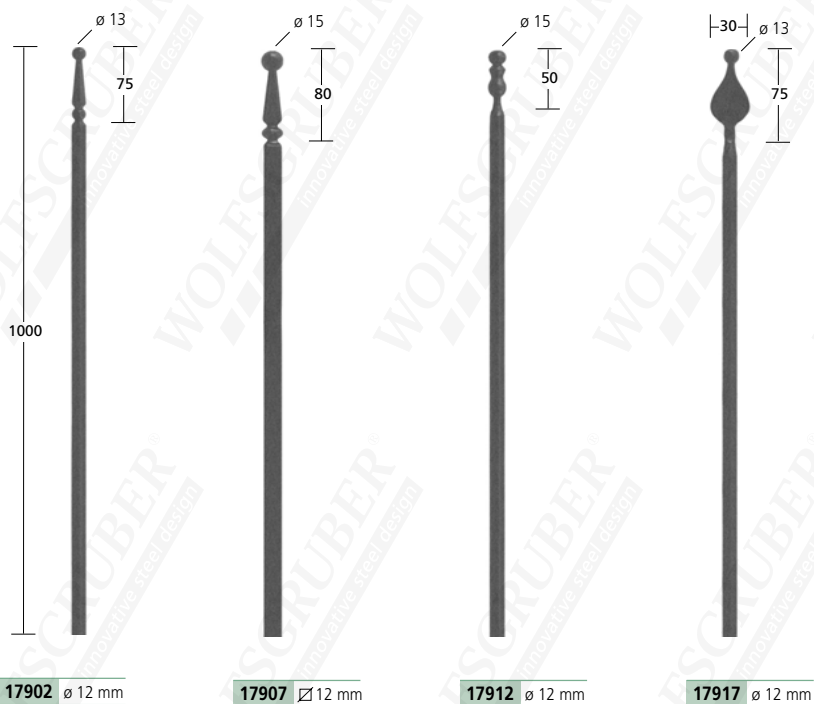

**PALETTI
STÄBE
RODS**





CAPOSALDI · ANFANGSSTÄBE · INITIAL RODS

forgiato a mano · handgeschmiedet · hand forged

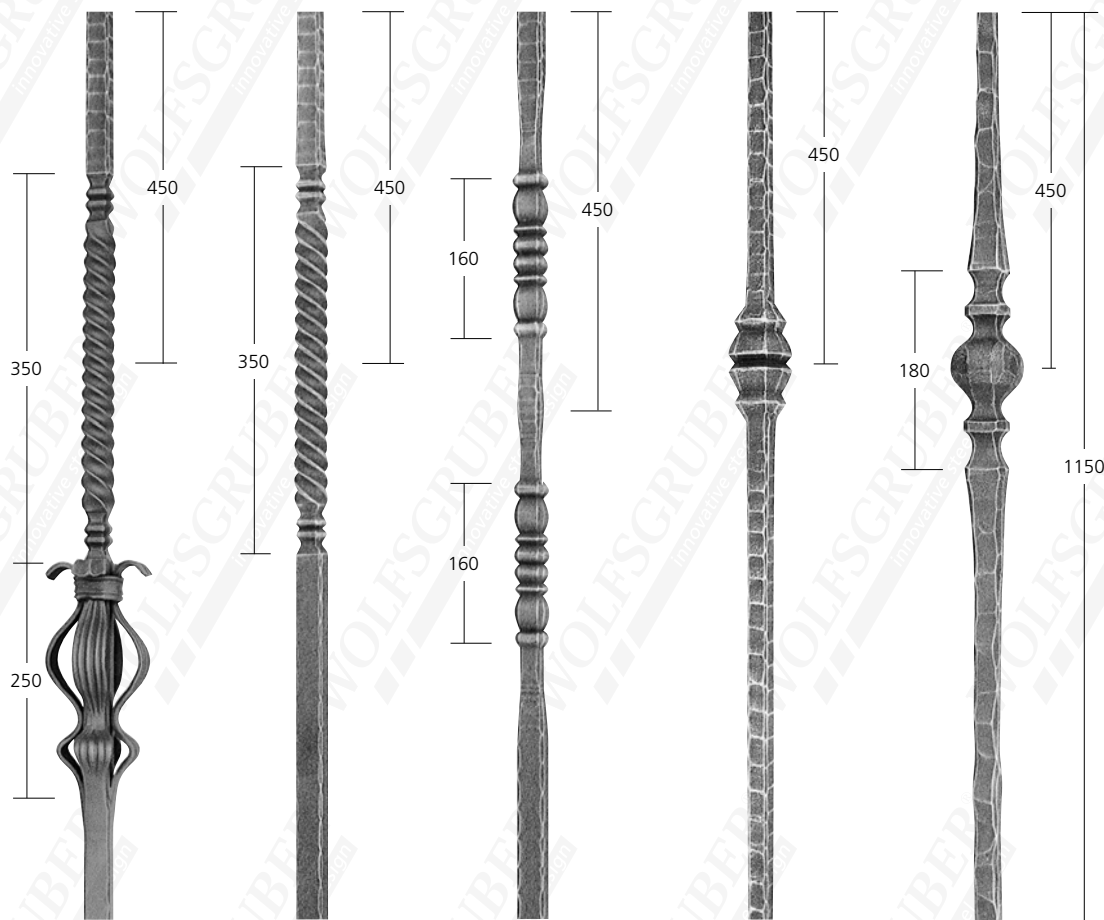

11102 $\varnothing 25$ mm
6,58 kg

11104 $\varnothing 25$ mm
5,54 kg

11106 $\varnothing 25$ mm
5,20 kg

11108 $\varnothing 25$ mm
5,63 kg

11110 $\varnothing 25$ mm
7,30 kg



forgiato a mano · handgeschmiedet · hand forged

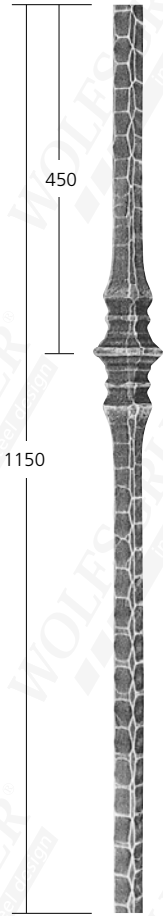

11112 $\varnothing 25$ mm
6,08 kg



11114 $\varnothing 25$ mm
4,58 kg



11116 $\varnothing 25$ mm
6,52 kg





forgiato a mano · handgeschmiedet · hand forged



11133 $\varnothing 25$ mm
5,80 kg



11135 $\varnothing 25$ mm
6,6 kg

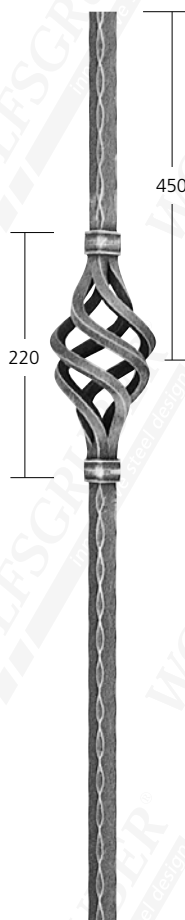

11202 $\varnothing 25$ mm
5,92 kg



11204 $\varnothing 20$ mm
3,88 kg



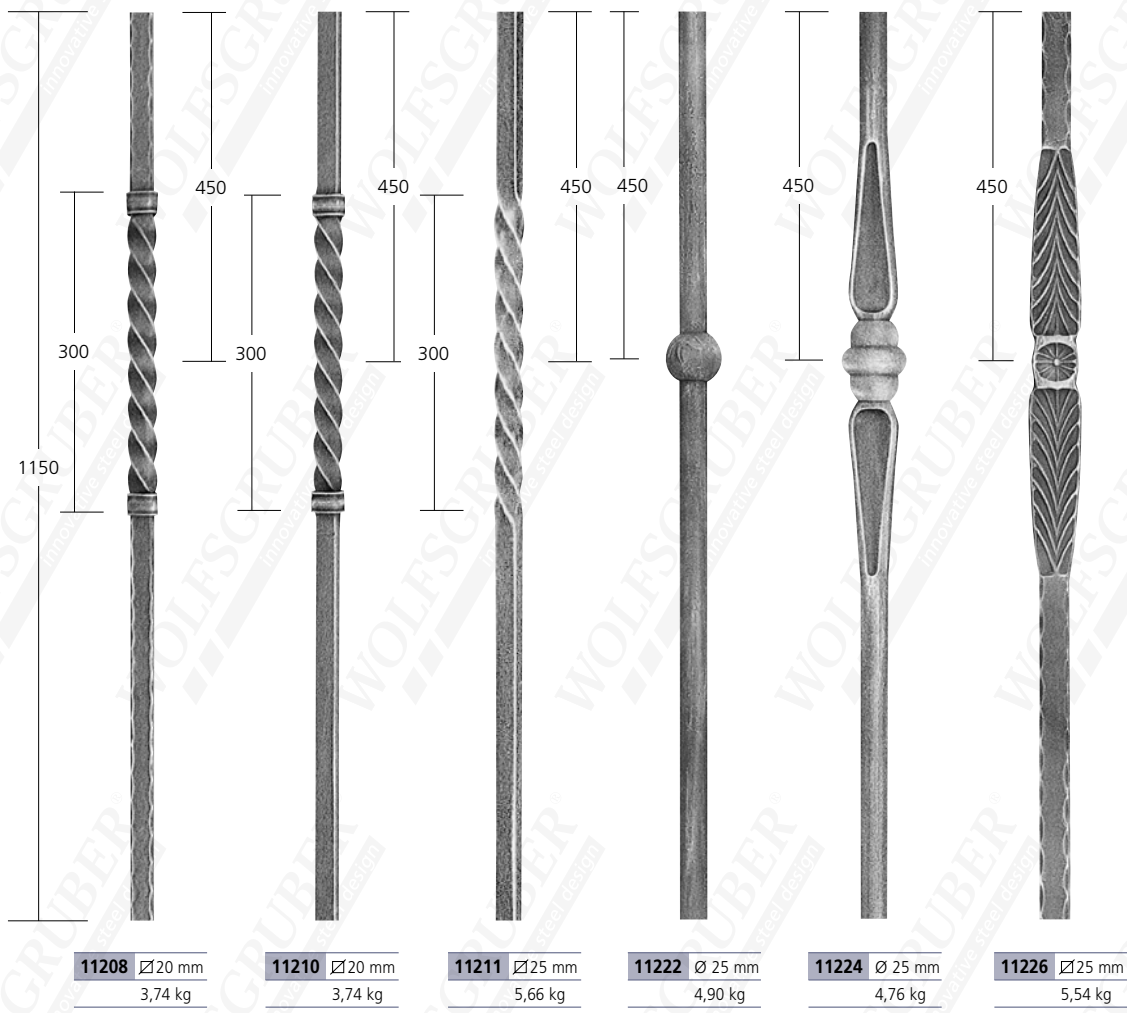

supporti ringhiera · Geländerstützen · rail supports

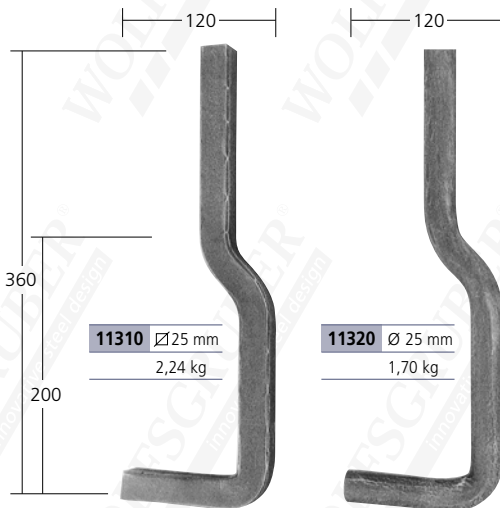

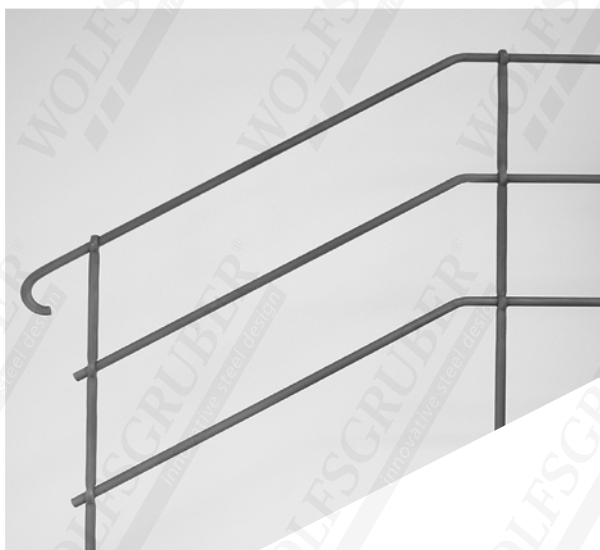
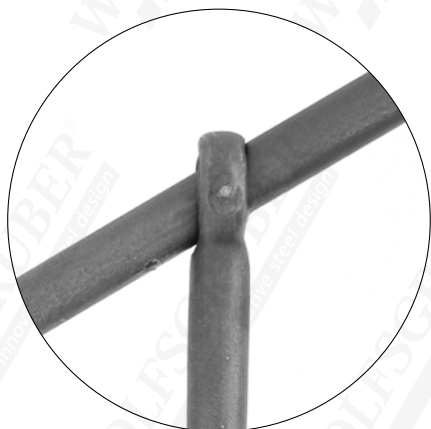
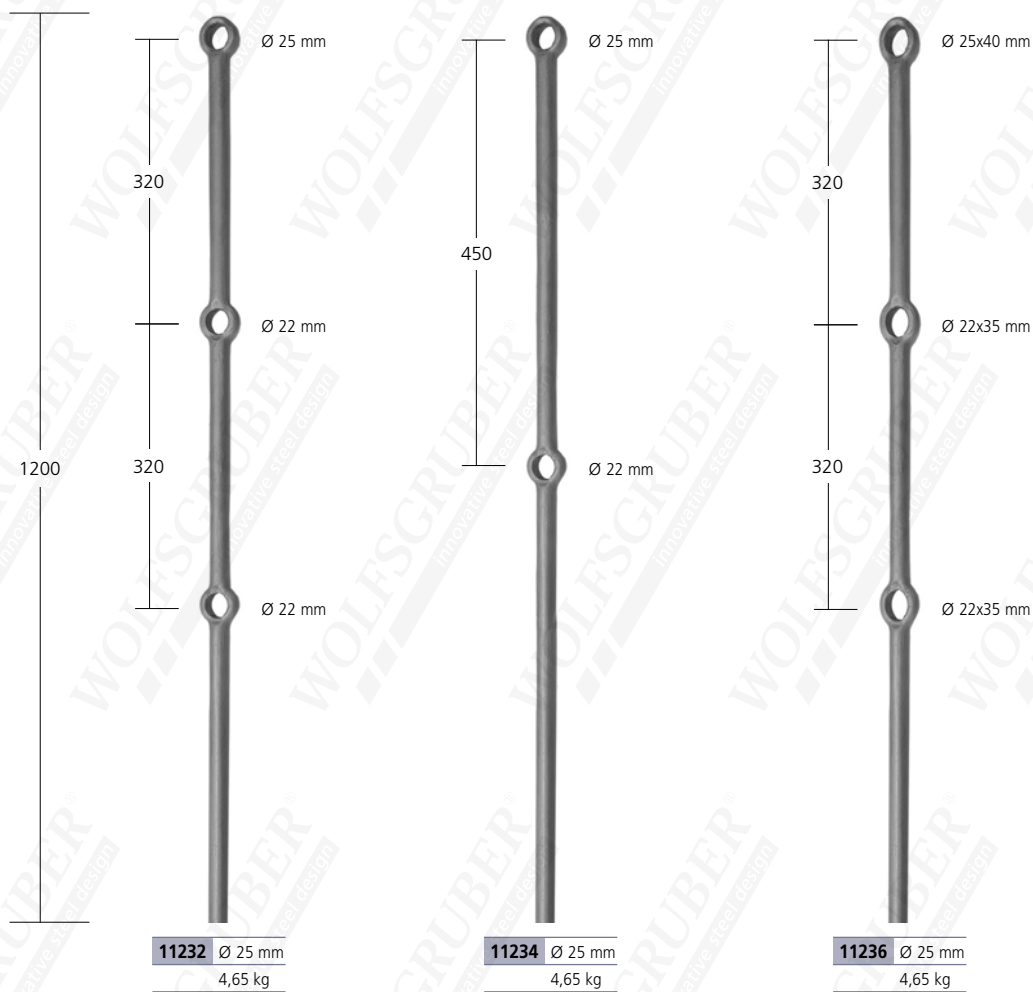

forgiato a mano · handgeschmiedet · hand forged

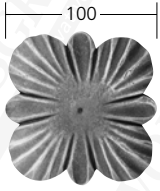

40610 Mat. 6 mm
0,36 kg



40620 Mat. 6 mm
0,62 kg

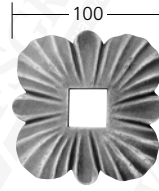

40618 Mat. 6 mm
0,32 kg
∅25,5 mm

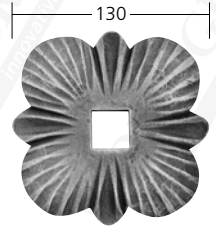

40628 Mat. 6 mm
0,58 kg
∅25,5 mm

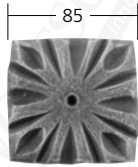

40630 Mat. 8 mm
0,40 kg

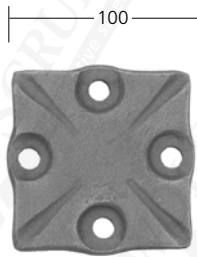

40632 Mat. 8 mm
0,40 kg

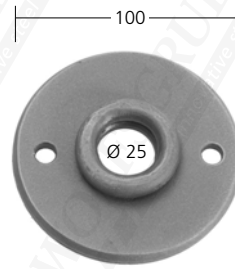

40622 Mat. 6 mm
0,34 kg

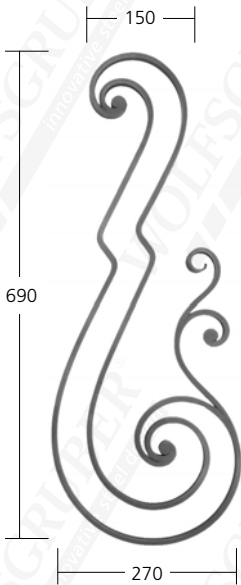

11242 Mat. 16x8 mm
4,20 kg

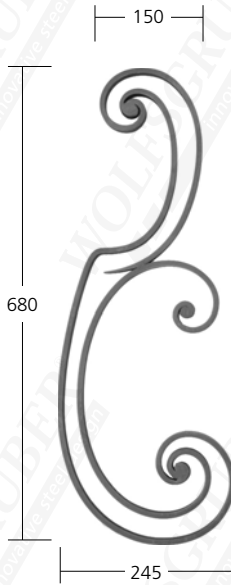

11244 Mat. 16x8 mm
2,66 kg

terminali a sfera · geländerkugeln · railing balls

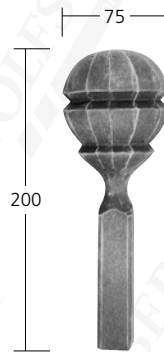

44010 ∅25 mm
2,46 kg

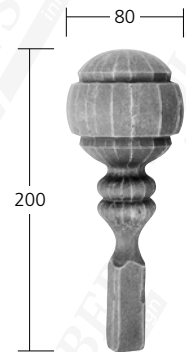

44020 ∅25 mm
2,82 kg

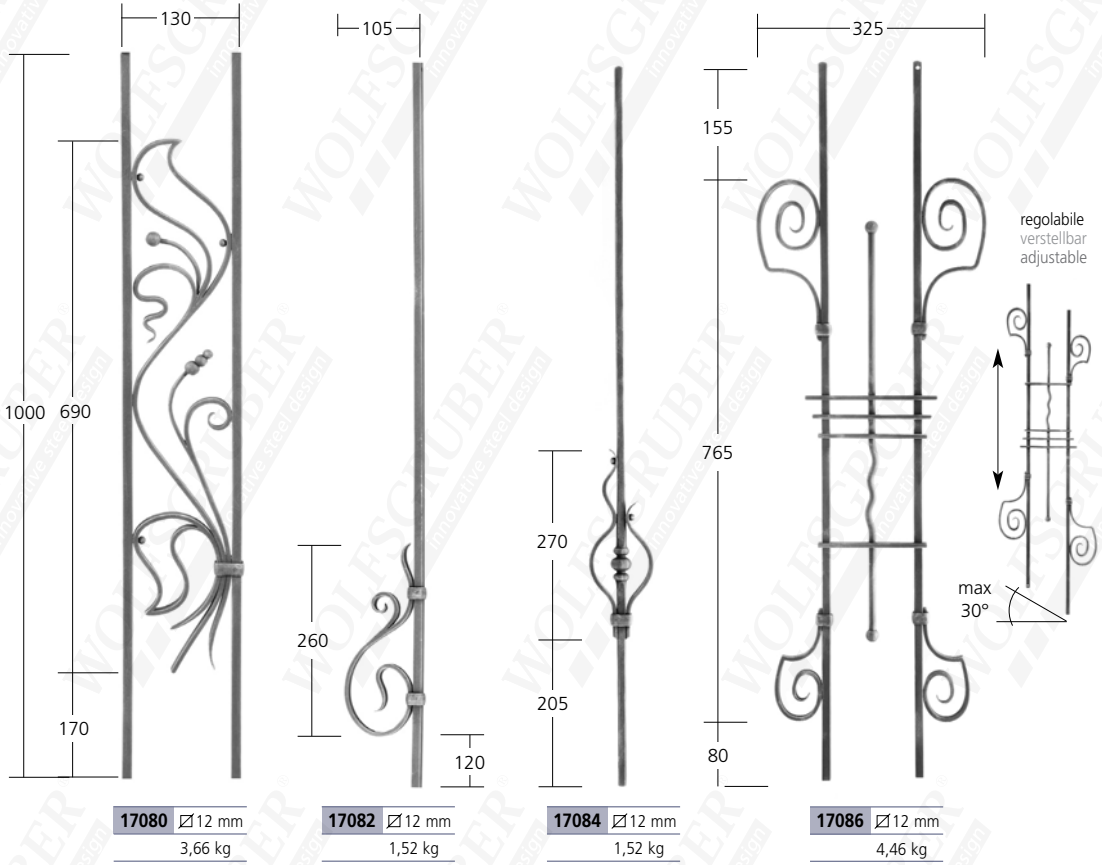

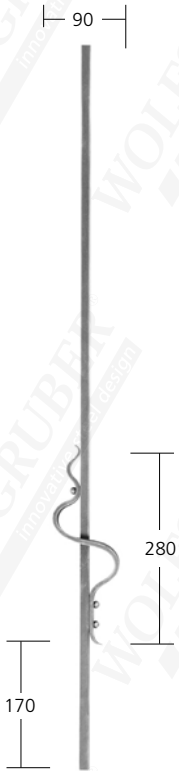

17090 \varnothing 12 mm
1,38 kg



17092 \varnothing 12 mm
1,20 kg



17094 \varnothing 12 mm
1,1 kg

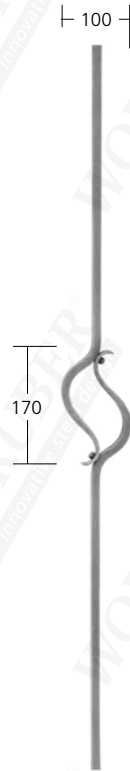

17096 \varnothing 12 mm
1,4 kg



17098 \varnothing 12 mm
1,5 kg



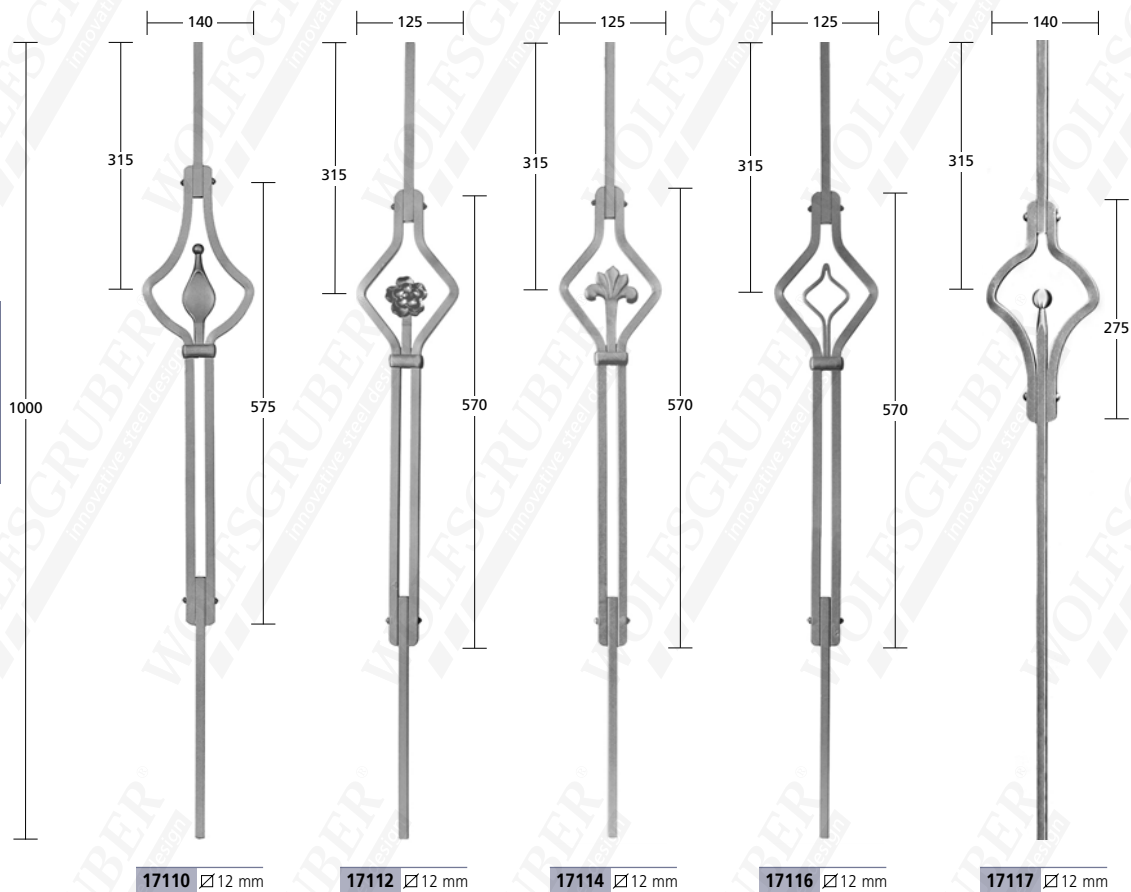



Cene
Trenta

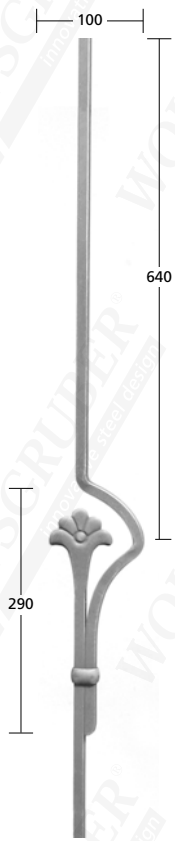

17119 Ø12 mm

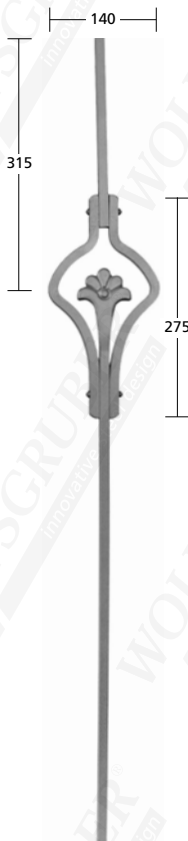

17120 Ø12 mm

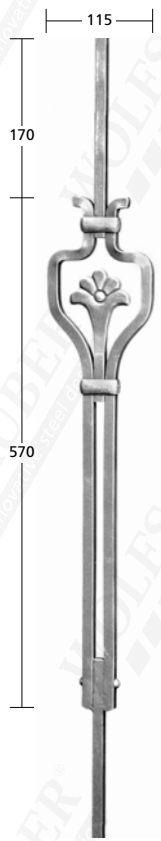

17121 Ø12 mm



17150 Ø12 mm

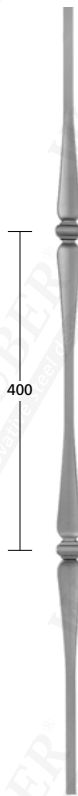

17151 Ø12 mm



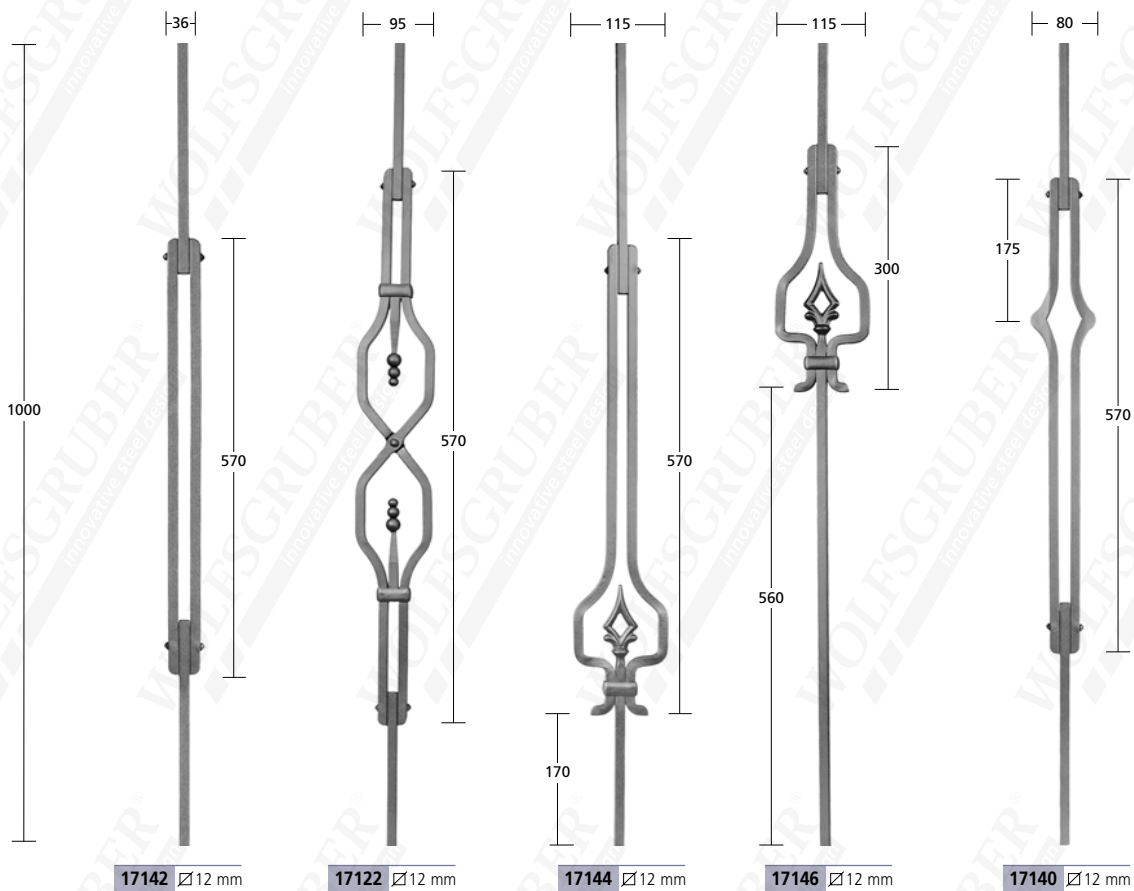

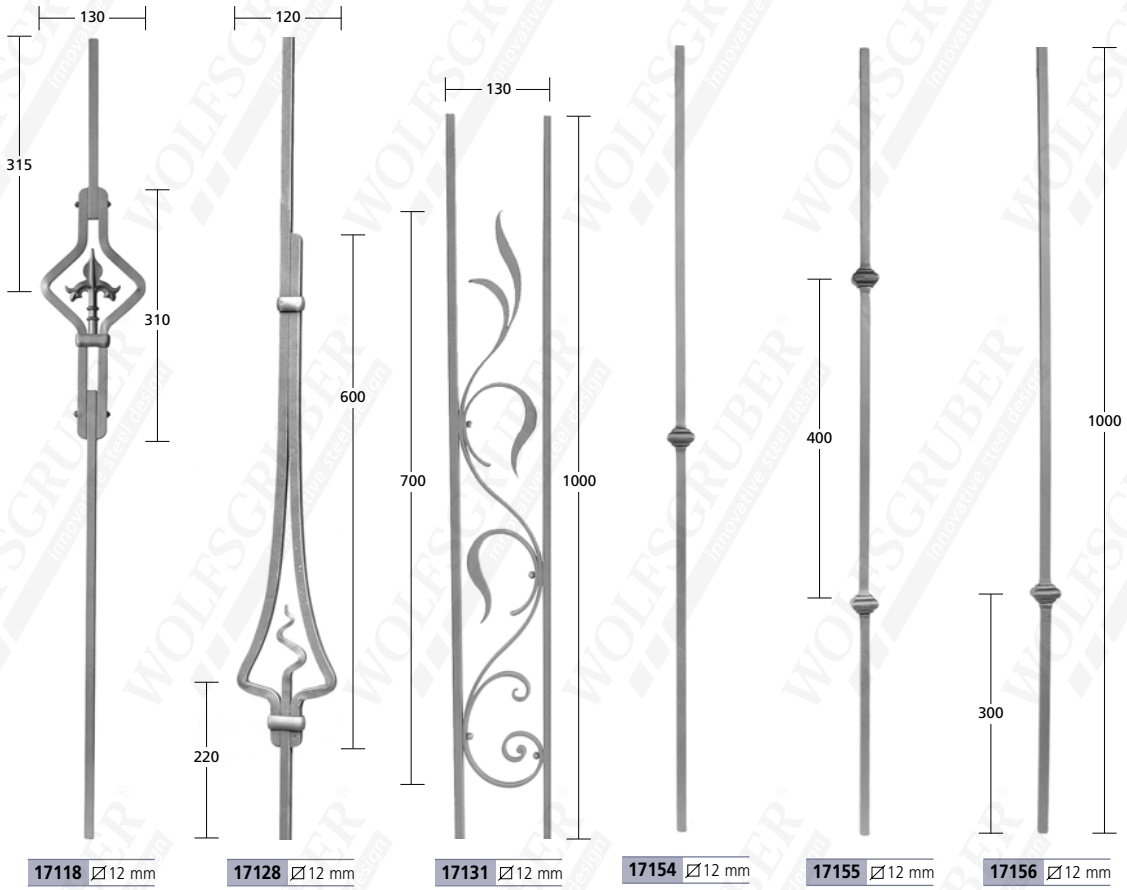



PALETTI · ZIERSTÄBE · ORNAMENTAL RODS

forgiato a mano · handgeschmiedet · hand forged

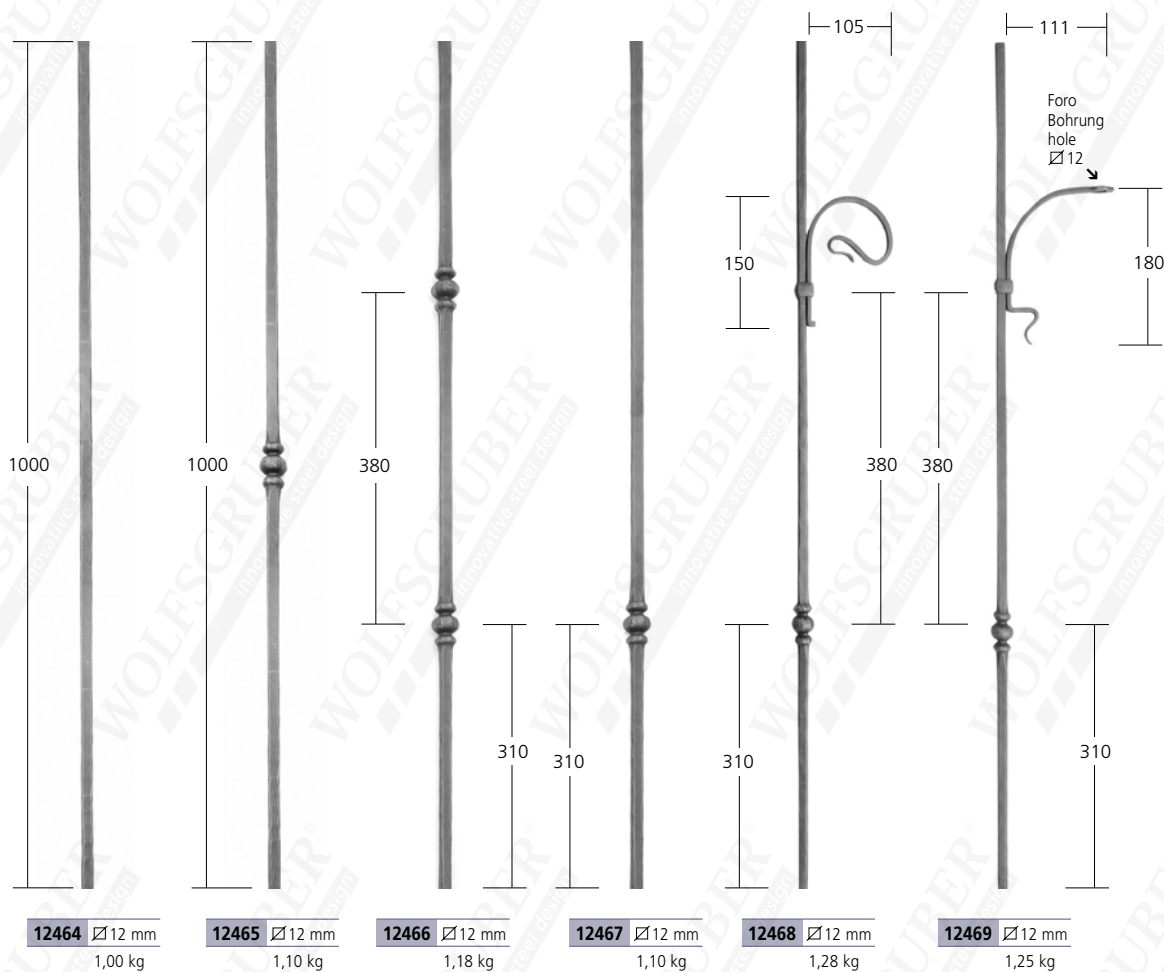

forgiato a mano · handgeschmiedet · hand forged

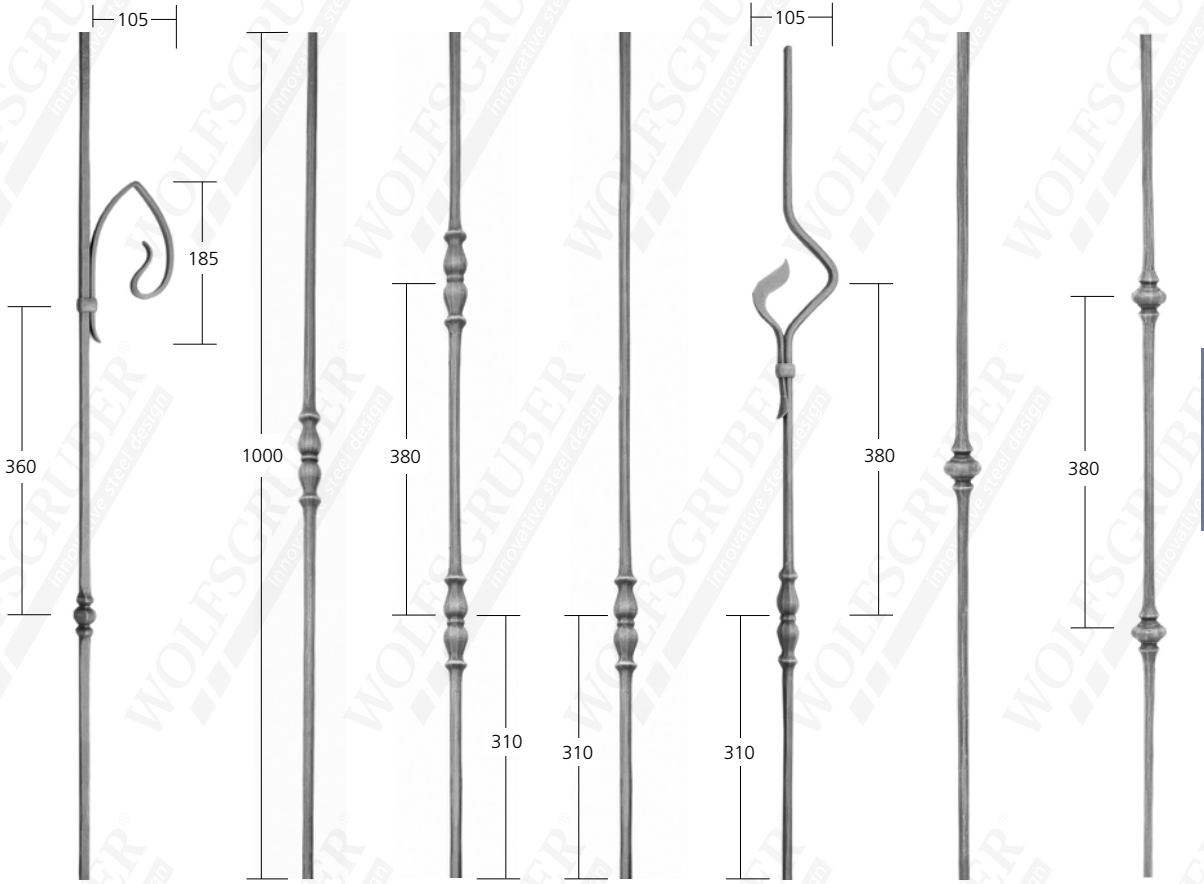

12470 Ø 12 mm
1,32 kg

12472 Ø 12 mm
1,05 kg

12473 Ø 12 mm
1,25 kg

12471 Ø 12 mm
1,05 kg

12476 Ø 12 mm
1,1 kg

12457 Ø 12 mm
1,00 kg

12458 Ø 12 mm
1,17 kg



forgiato a mano · handgeschmiedet · hand forged

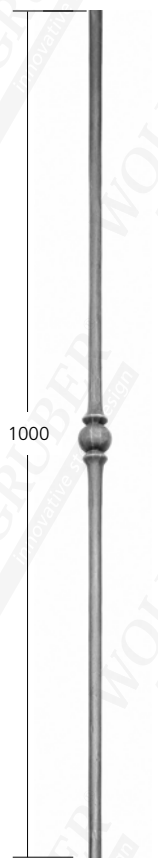

12477 Ø 14 mm

1,33 kg

liscio · glatt · smooth

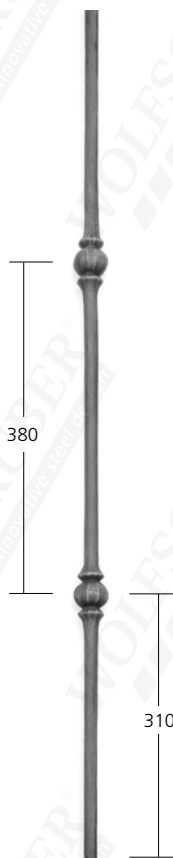

12478 Ø 14 mm

1,72 kg

liscio · glatt · smooth



12479 Ø 14 mm

1,33 kg

liscio · glatt · smooth



12486 Ø 14 mm

1,46 kg

liscio · glatt · smooth



12474 Ø 14-12 mm

0,98 kg

liscio · glatt · smooth

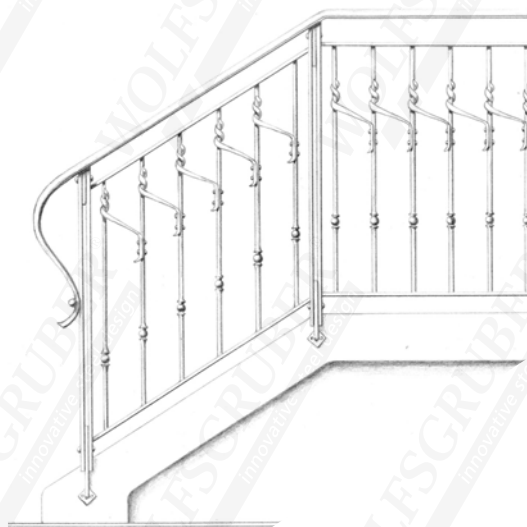

forgiato a mano · handgeschmiedet · hand forged

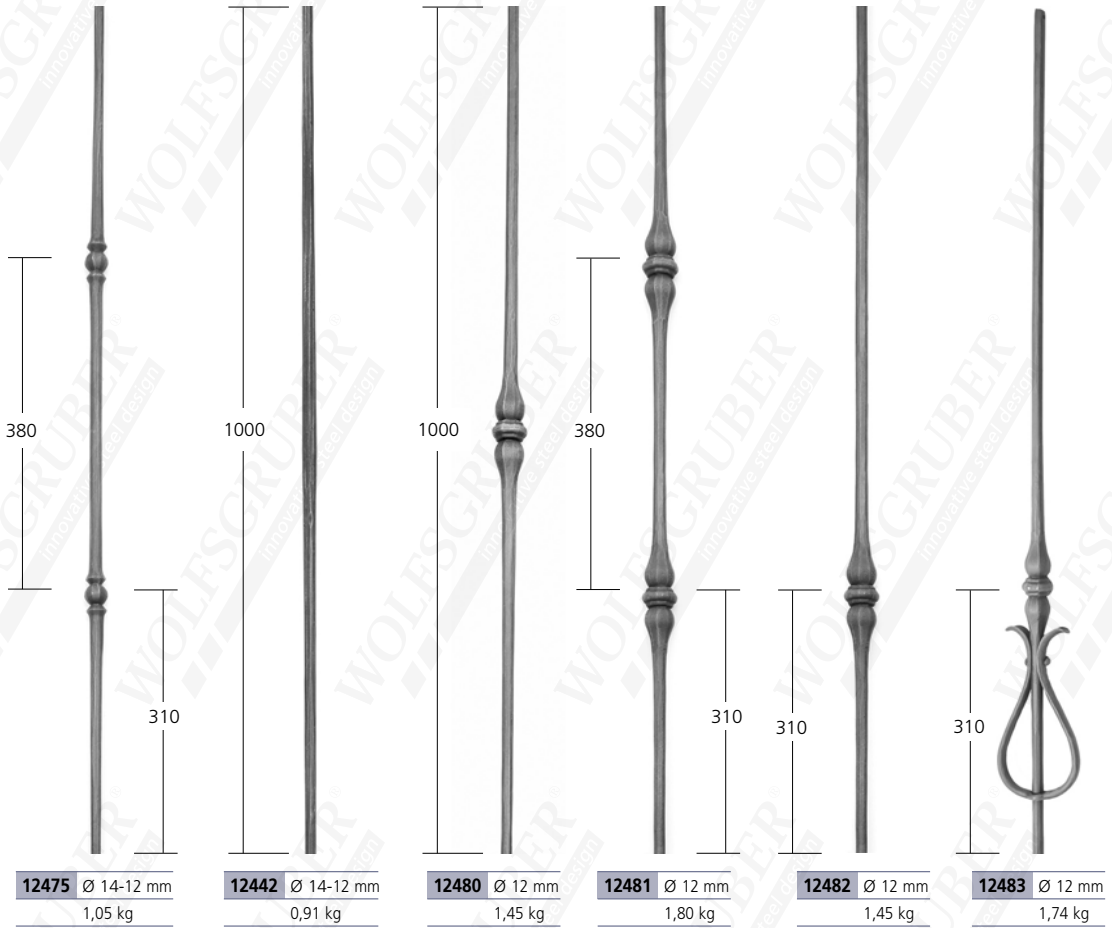

liscio · glatt · smooth

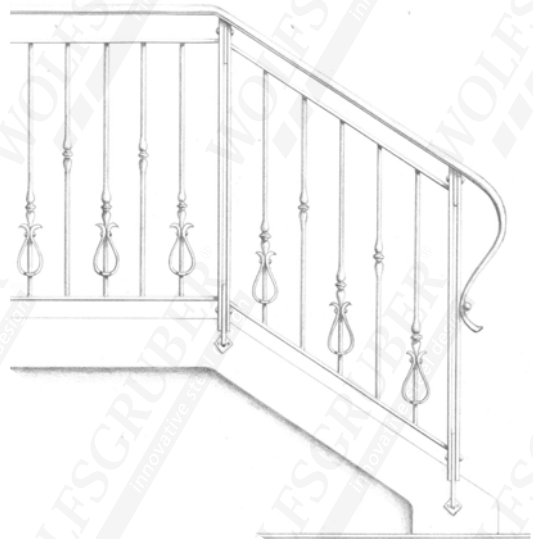



PALETTI · ZIERSTÄBE · ORNAMENTAL RODS

forgiato a mano · handgeschmiedet · hand forged

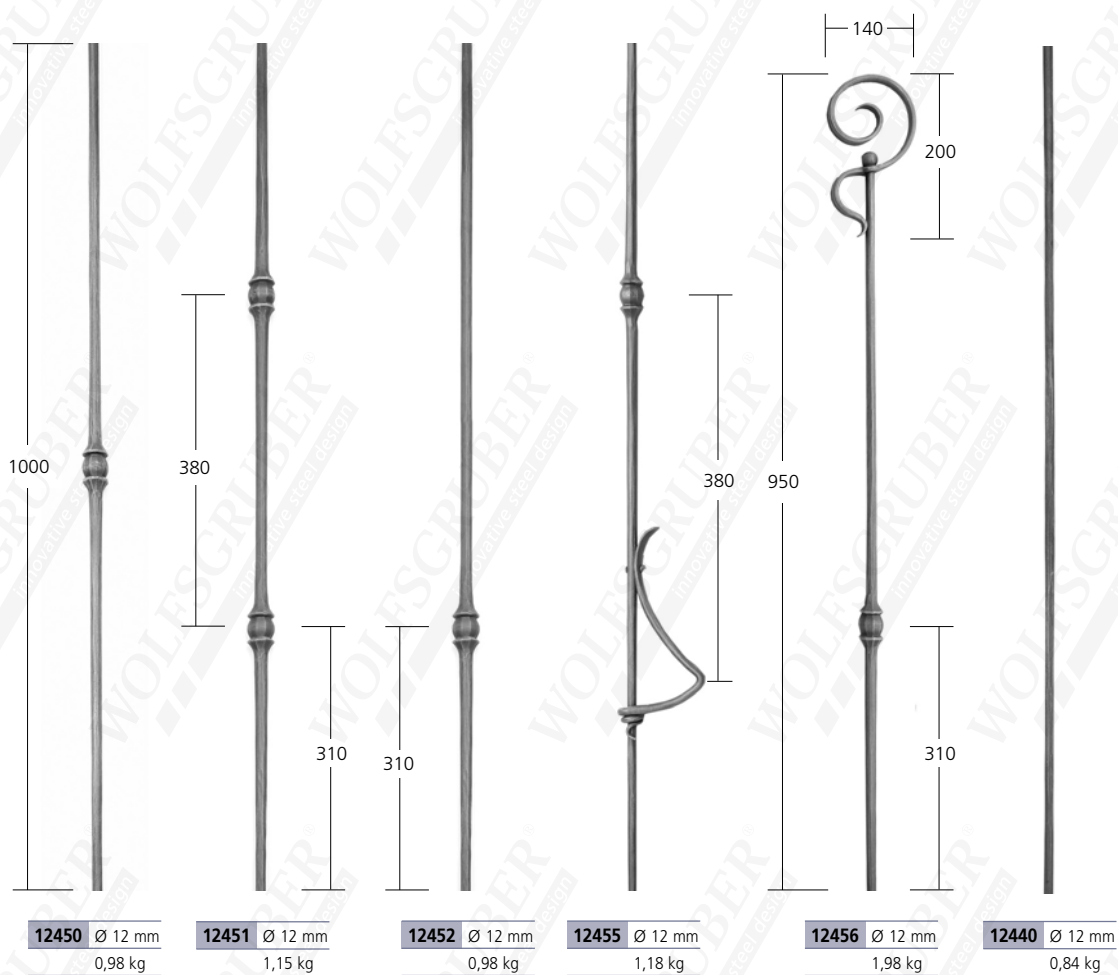



forgiato a mano · handgeschmiedet · hand forged

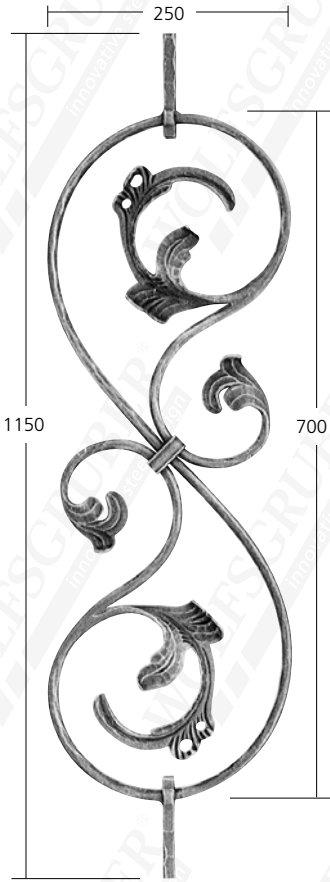

12102 ∅ 14 mm
3,20 kg

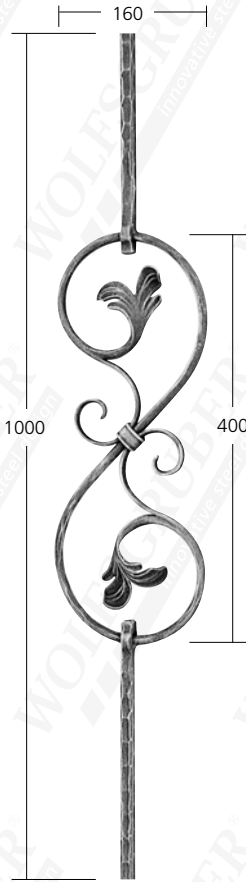

12104 ∅ 14 mm
1,48 kg



12106 ∅ 14 mm
1,42 kg



12108 ∅ 14 mm
1,74 kg



12204 ∅ 14 mm
1,93 kg





PALETTI · ZIERSTÄBE · ORNAMENTAL RODS

forgiato a mano · handgeschmiedet · hand forged

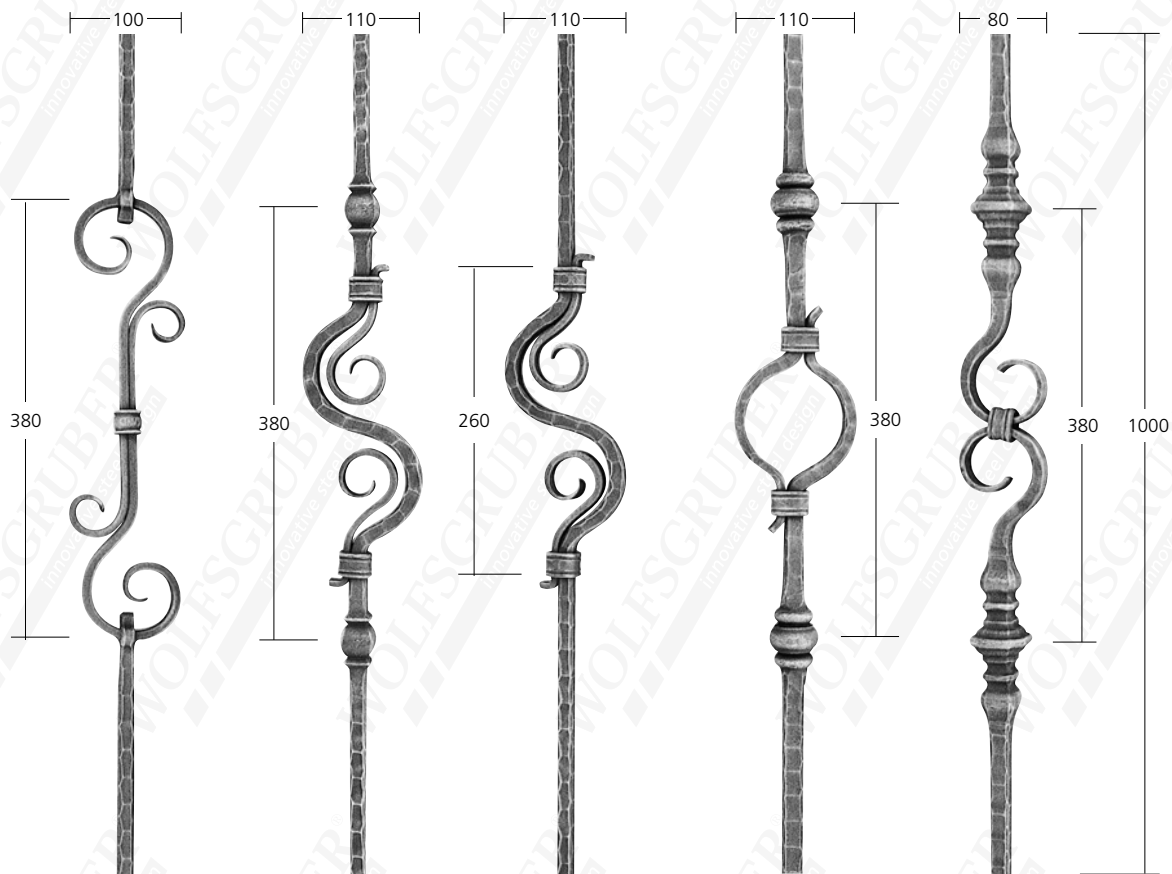

12206 ∅14 mm
1,63 kg

12208 ∅14 mm
2,32 kg

12210 ∅14 mm
1,70 kg

12302 ∅14 mm
3,04 kg

12304 ∅14 mm
3,52 kg



forgiato a mano · handgeschmiedet · hand forged

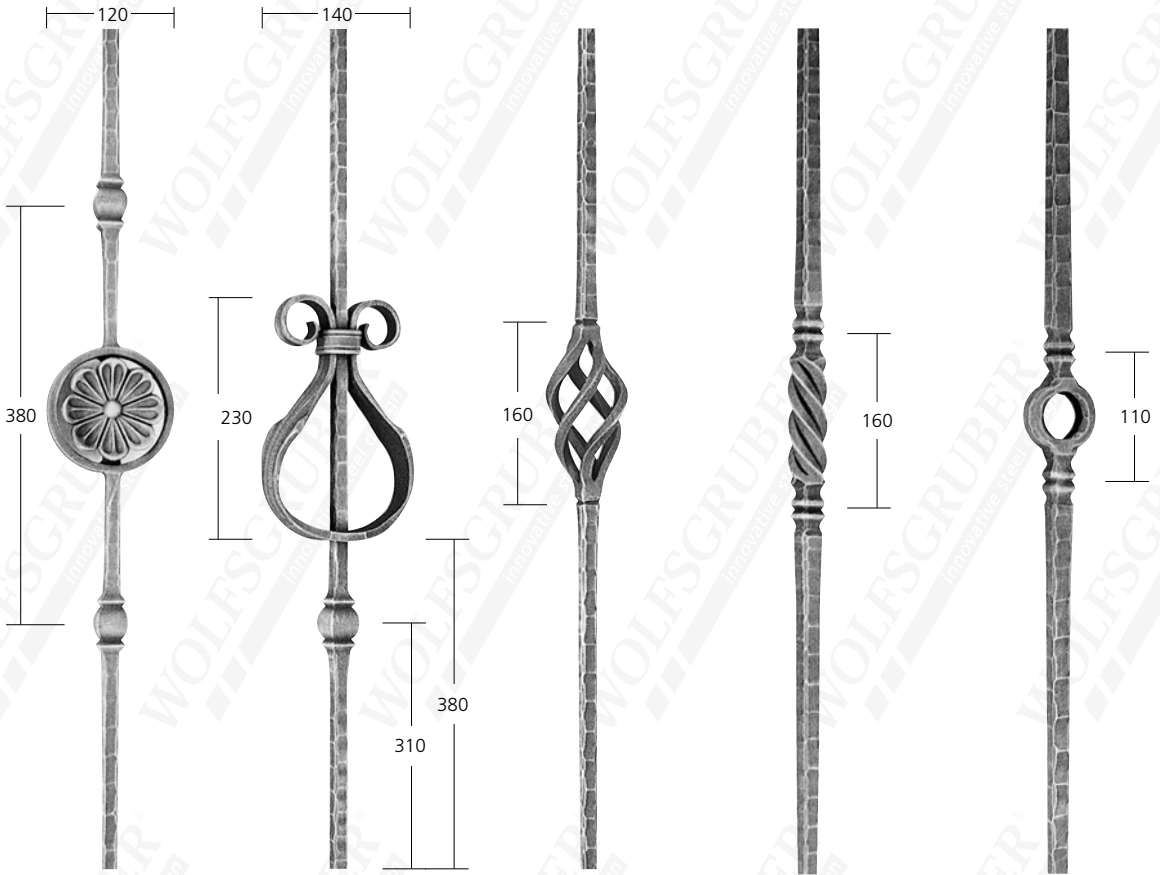

12310 ∅ 14 mm
2,48 kg

12312 ∅ 14 mm
2,56 kg

12314 ∅ 14 mm
1,65 kg

12306 ∅ 14 mm
2,34 kg

12308 ∅ 14 mm
2,32 kg



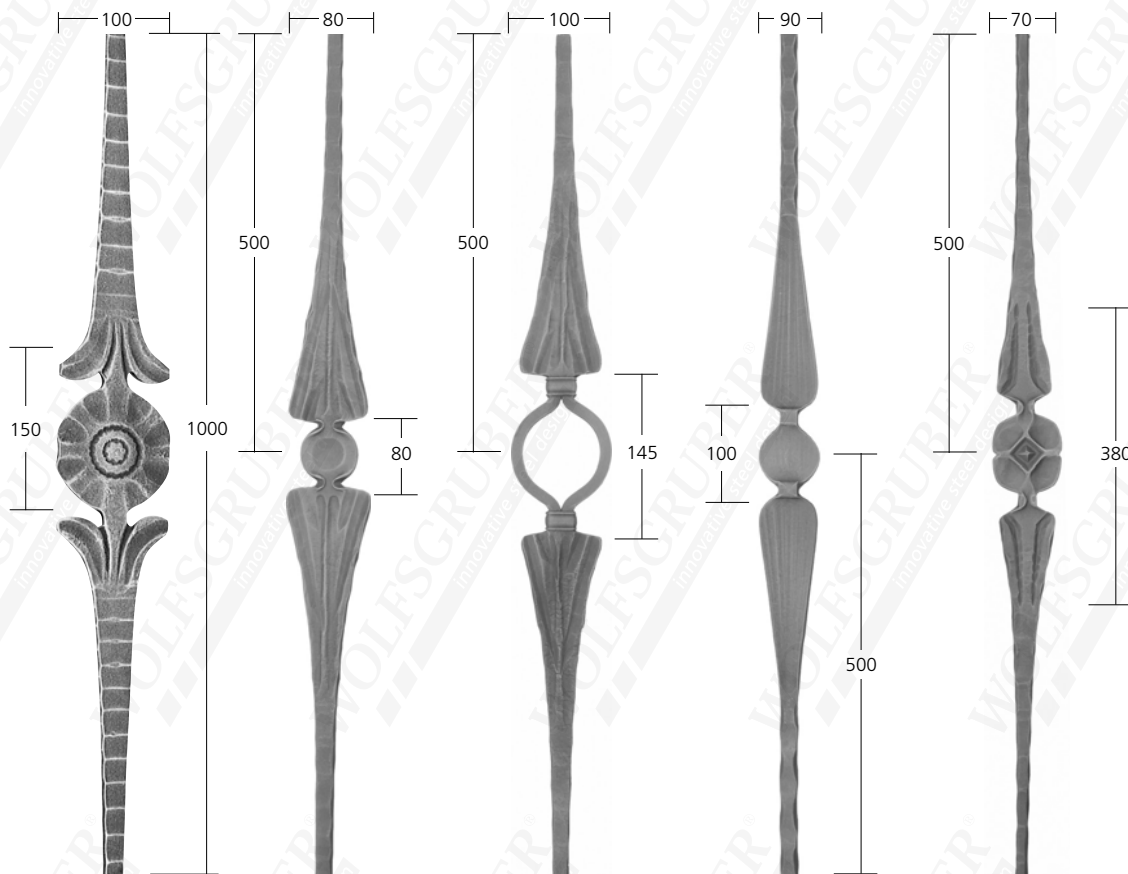

12316 Mat. 8x18 mm
2,52 kg

12318 Mat. 14x14 mm
2,35 kg

12320 Mat. 20x12 mm
2,30 kg

12322 Mat. 14x14 mm
1,75 kg

12324 Mat. 12x12 mm
2,30 kg





12401 $\varnothing 14$ mm
1,48 kg

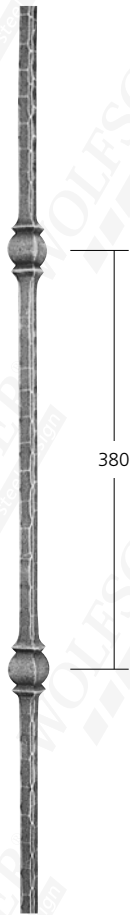

12402 $\varnothing 14$ mm
1,70 kg



12403 $\varnothing 14$ mm
1,48 kg



12405 $\varnothing 14$ mm
1,54 kg

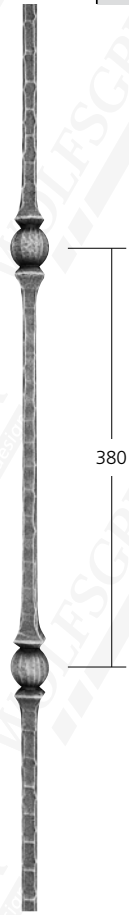

12406 $\varnothing 14$ mm
1,78 kg





12408 \varnothing 14 mm
2,40 kg

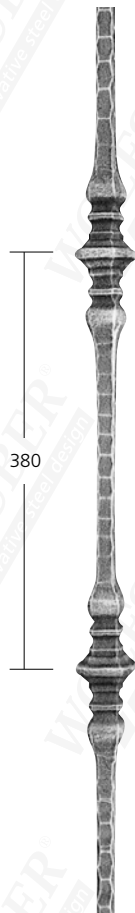

12409 \varnothing 14 mm
3,12 kg

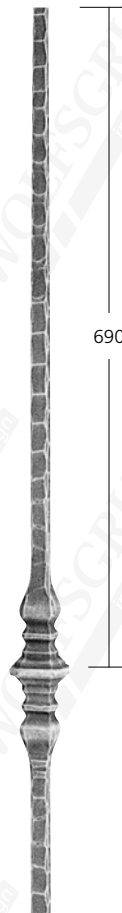

12410 \varnothing 14 mm
2,40 kg



12412 \varnothing 14 mm
2,20 kg

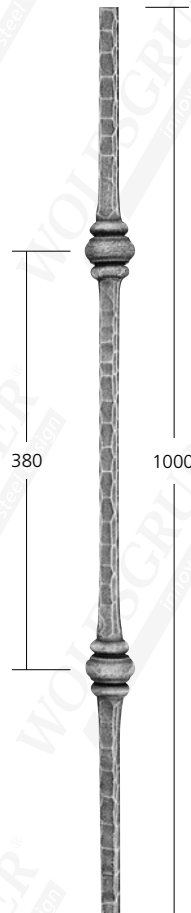

12413 \varnothing 14 mm
2,50 kg



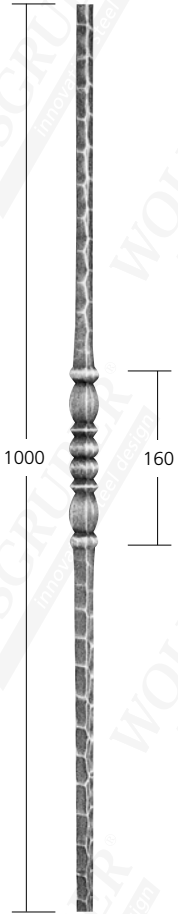

12416 \varnothing 14 mm
1,50 kg



12417 \varnothing 14 mm
1,46 kg



12420 \varnothing 14 mm
1,46 kg



12422 \varnothing 14 mm
1,50 kg



12502 \varnothing 12 mm
1,06 kg



12504 \varnothing 12 mm
1,02 kg



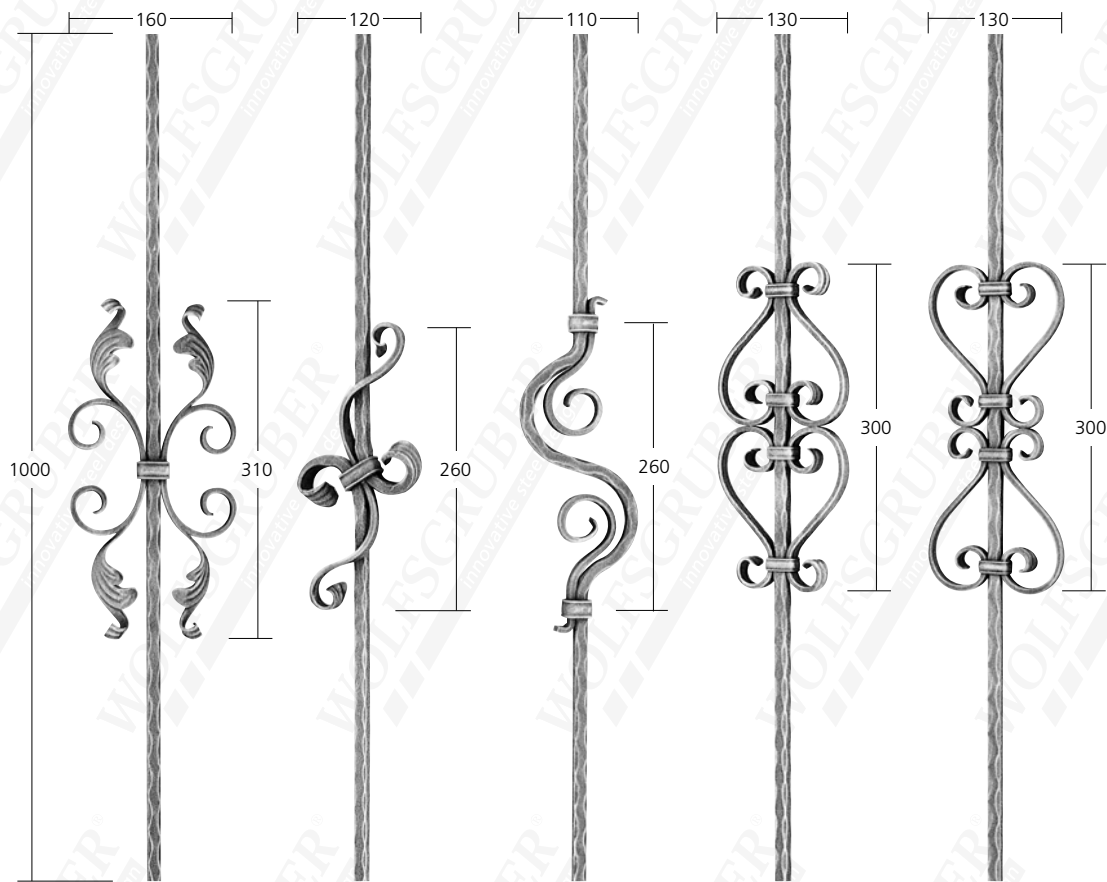

12510 Ø 12 mm
1,68 kg

12512 Ø 12 mm
1,46 kg

12514 Ø 12 mm
1,36 kg

12516 Ø 12 mm
1,75 kg

12518 Ø 12 mm
1,75 kg





12528 $\varnothing 12$ mm
1,11 kg

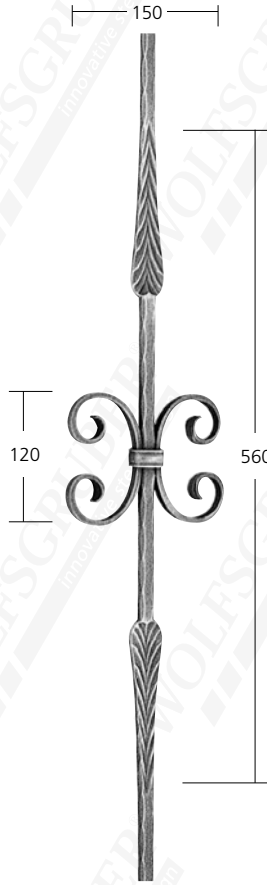

12532 $\varnothing 12$ mm
1,46 kg

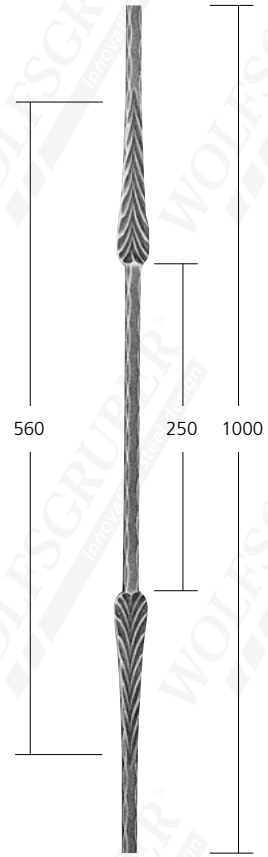

12529 $\varnothing 12$ mm
1,11 kg



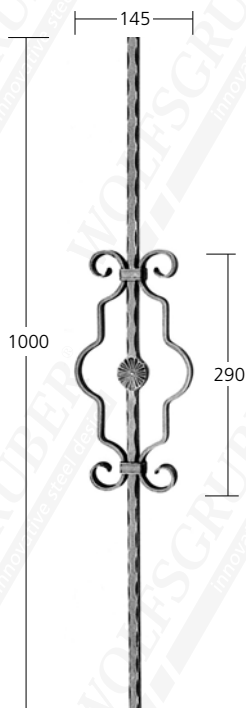

12540 ∅12 mm
1,62 kg



12542 ∅12 mm
3,04 kg

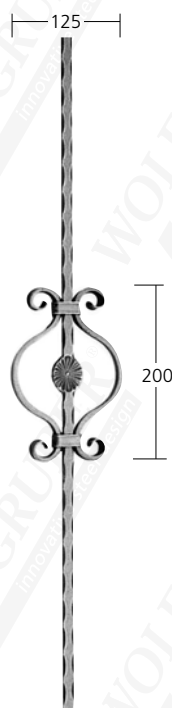

12544 ∅12 mm
1,50 kg

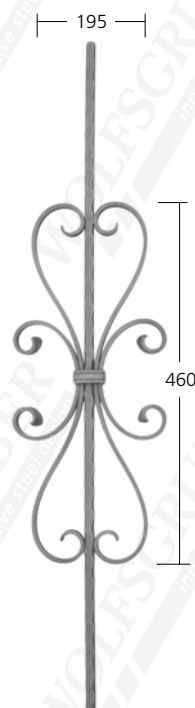

12545 ∅12 mm
2,00 kg



12546 ∅12 mm
1,09 kg

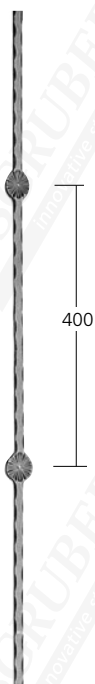

12548 ∅12 mm
1,12 kg



12550 ∅12 mm
1,54 kg

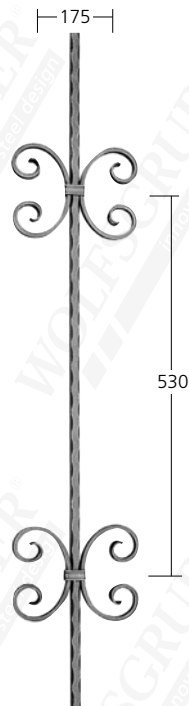

12552 ∅12 mm
1,96 kg



12560 ∅12 mm
1,48 kg



12562 ∅12 mm
1,54 kg

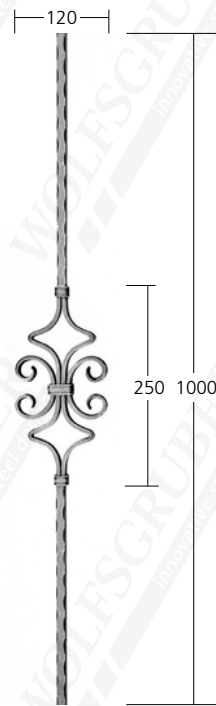

12564 ∅12 mm
1,48 kg



12566 ∅12 mm
1,46 kg

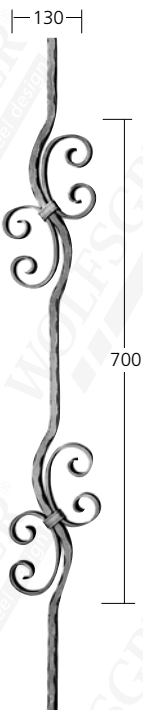

12568 ∅12 mm
1,80 kg



12570 ∅12 mm
1,44 kg

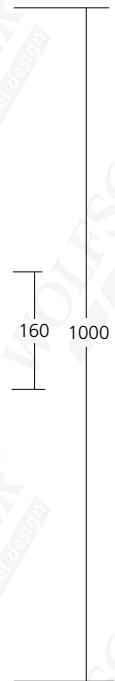

12572 ∅12 mm
1,18 kg



12602  12 mm
0,97 kg

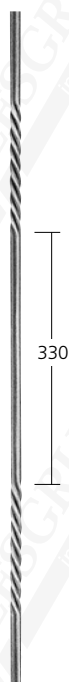

12604  12 mm
0,97 kg



12610  12 mm
1,14 kg



12612  12 mm
1,26 kg



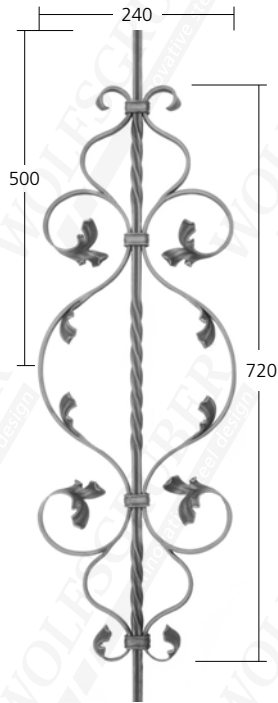

12620 12 mm
2,40 kg

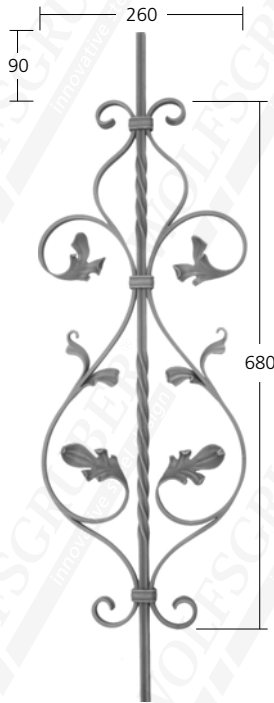

12621 12 mm
2,30 kg

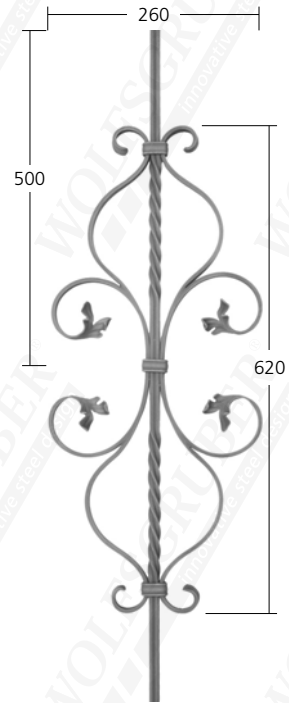

12622 12 mm
2,10 kg

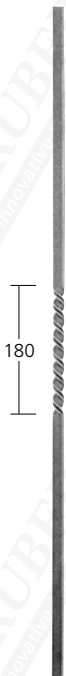

12640 16x8 mm
0,88 kg



12642 16x8 mm
0,88 kg



12650 16x8 mm
1,86 kg

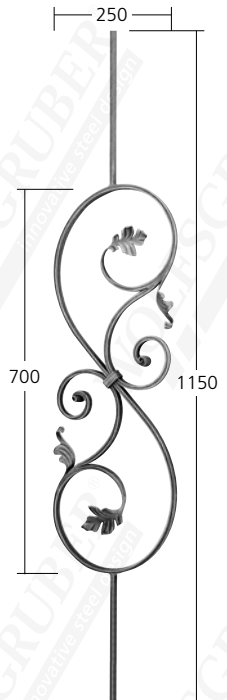

12652 16x8 mm
3,20 kg

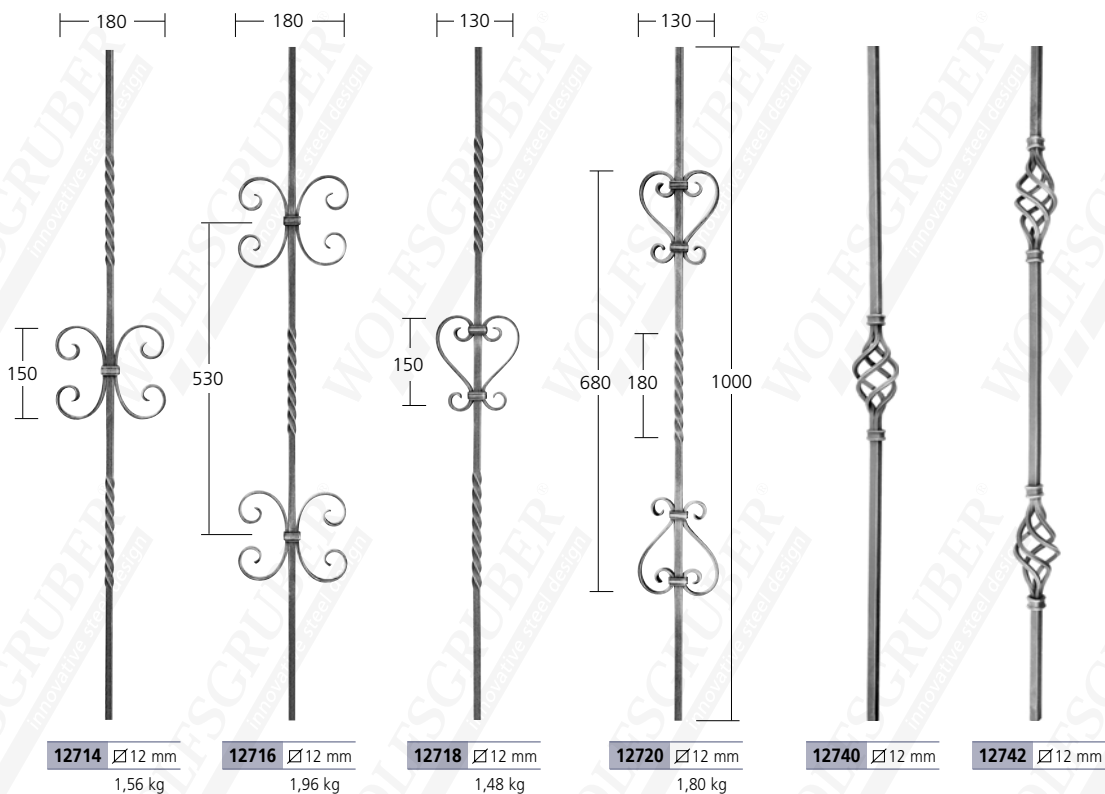
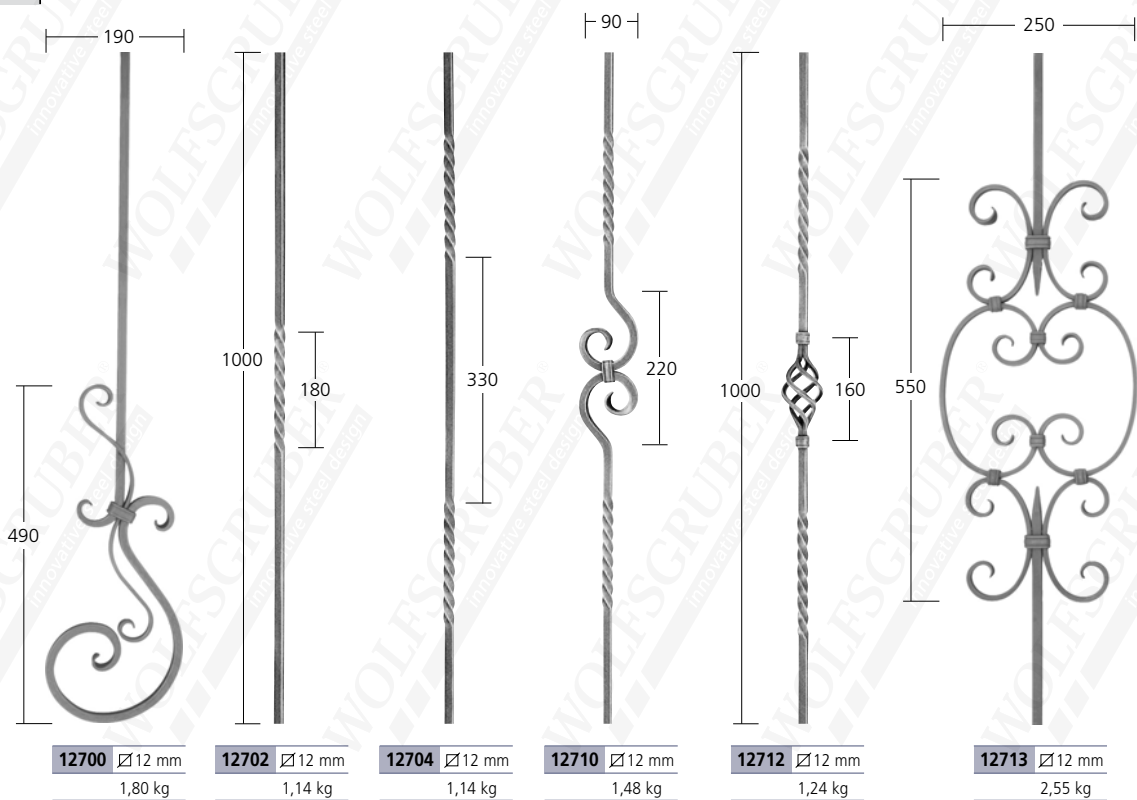

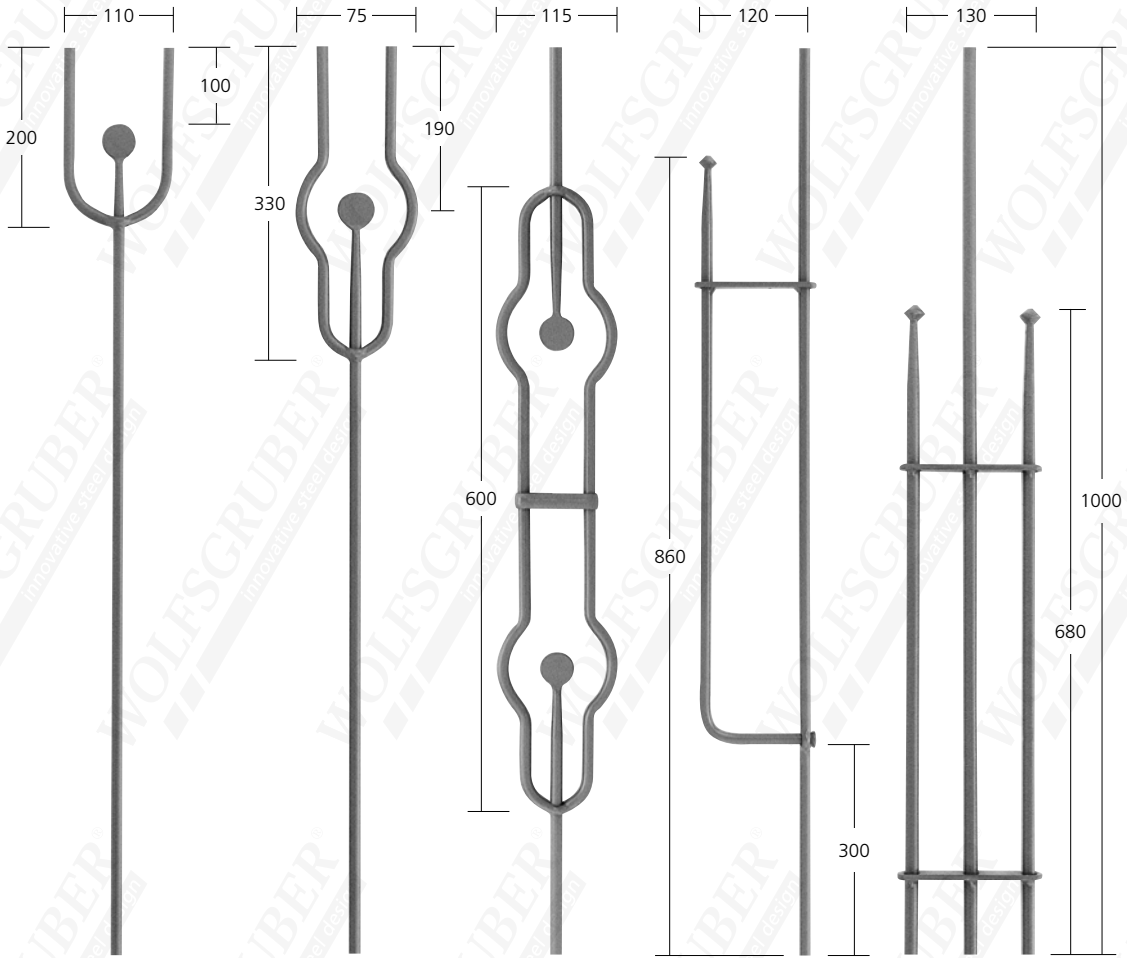

14002 Ø 12 mm
1,18 kg

14004 Ø 12 mm
1,32 kg

14006 Ø 12 mm
1,82 kg

14008 Ø 12 mm
1,62 kg

14010 Ø 12 mm
2,28 kg



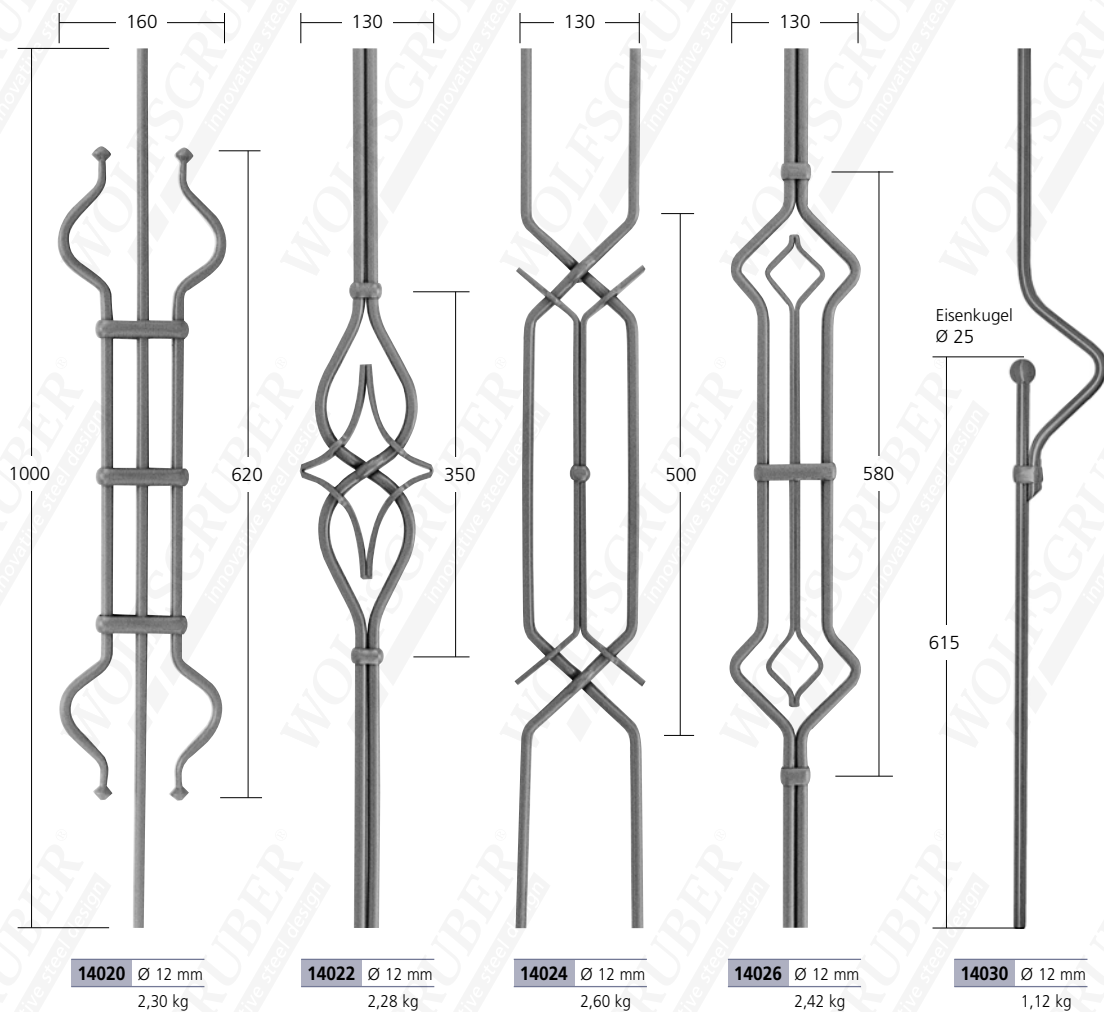



14015 Ø 12 mm
2,38 kg



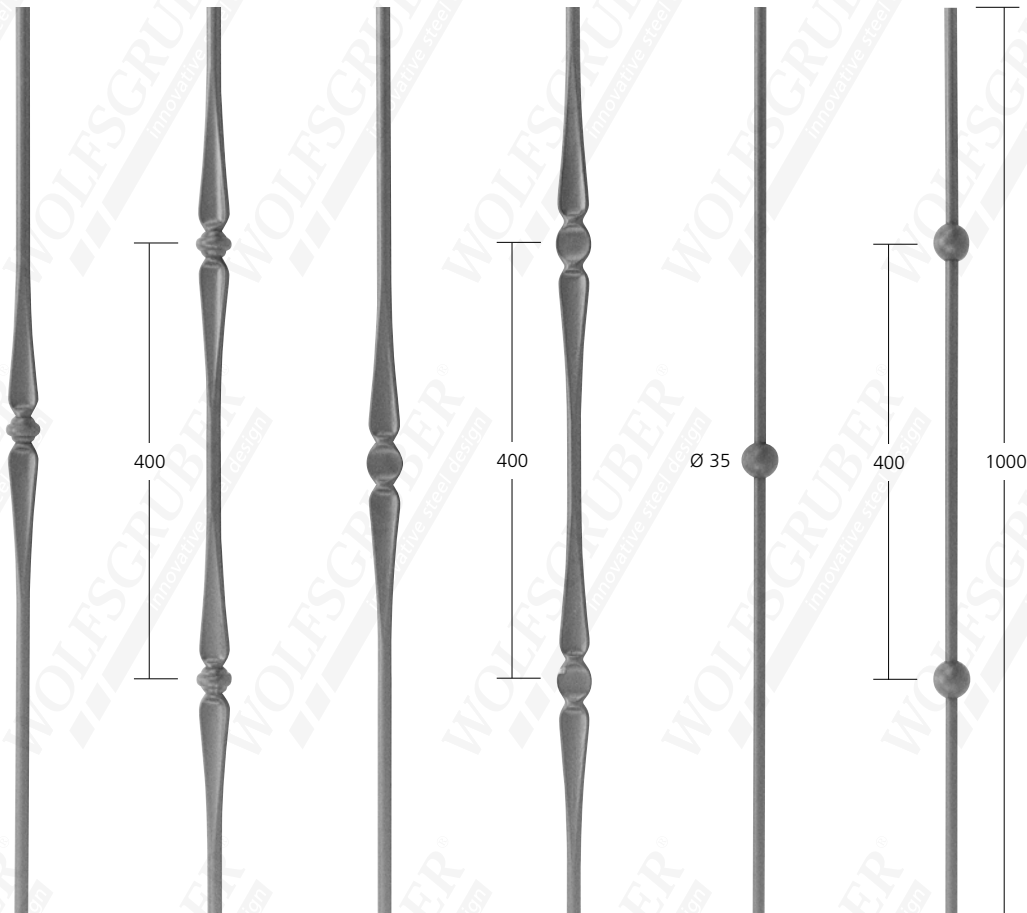

14200 Ø 12 0,93 kg
14202 Ø 14 1,28 kg

14201 Ø 12 1,02 kg
14203 Ø 14 1,36 kg

14210 Ø 14 mm
1,20 kg

14211 Ø 14 mm
1,20 kg

14220 Ø 12 mm
1,04 kg

14221 Ø 12 mm
1,16 kg





borchie in ottone lucidate e verniciate a forno · Messinghülsen hochglanzpoliert und einbrennlackiert
 enveloping bodies of brass highly polished and stove enamelled

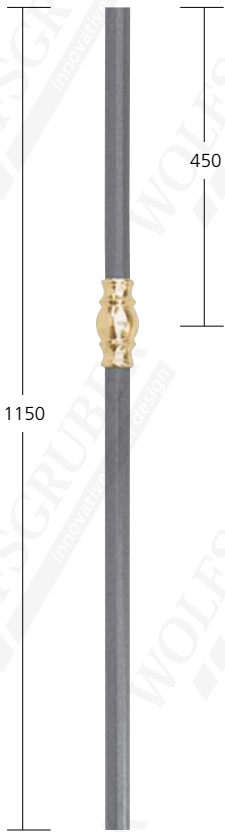

11435 Ø 25 mm
4,80 kg



11440 Ø 25 mm
4,80 kg



11455 Ø 25 mm
4,90 kg



11456 Ø 25 mm
4,90 kg



11835 Mat. Ø 105x1x25 mm
0,09 kg
foro Loch - hole Ø 25,5 mm



11830 Mat. Ø 100x6 mm
0,34 kg
foro Loch - hole Ø 25,5 mm

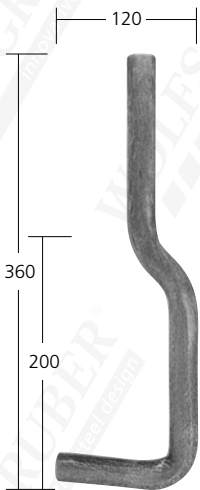

11320 Ø 25 mm
1,70 kg



11810 Ø 25 mm
2,34 kg



distanza dal muro: 40 mm
 Wandabstand: 40 mm
 distance to wall: 40 mm

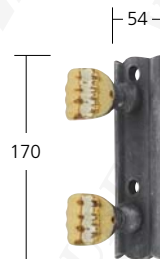

11815 foro Loch - hole Ø 25 mm
1,00 kg



borchie in ottone lucidate e verniciate a forno ·
 Messinghülsen hochglanzpoliert und einbrennlackiert
 enveloping bodies of brass highly polished and stove
 enamelled

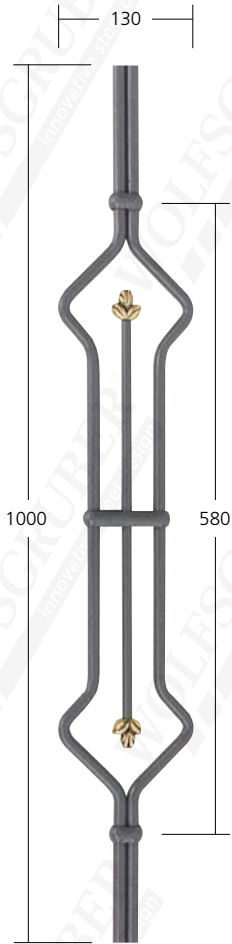

15012 Ø 12 mm
2,30 kg



15014 Ø 12 mm
2,20 kg



15016 Ø 14 mm
1,35 kg



15018 Ø 14 mm
1,84 kg

borchie in ottone lucidate e verniciate a forno ·
Messinghülsen hochglanzpoliert und einbrennlackiert
enveloping bodies of brass highly polished and stove
enamelled



borchie in ottone lucidate e verniciate a forno · Messinghülsen hochglanzpoliert und einbrennlackiert
 enveloping bodies of brass highly polished and stove enamelled



15202 Ø 12 mm
0,96 kg

15203 Ø 12 mm
1,06 kg

15206 Ø 12 mm
1,08 kg

15208 Ø 12 mm
1,10 kg

15212 Ø 12 mm
1,20 kg

da avvitare
verschraubbar
screwable

da avvitare
verschraubbar
screwable



borchie in ottone lucidate e verniciate a forno · Messinghülsen hochglanzpoliert und einbrennlackiert
 enveloping bodies of brass highly polished and stove enamelled



lance con foro · Zaunspitzen mit Bohrung · spears with hole

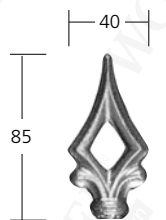

↑ foro
Bohrung
hole
Ø 12,5

41300



↑ foro
Bohrung
hole
Ø 12,5

41315

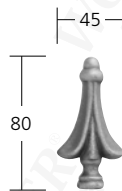

↑ foro
Bohrung
hole
Ø 12,5

41323

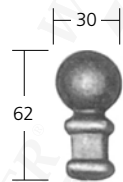

↑ foro
Bohrung
hole
Ø 12,5

41333

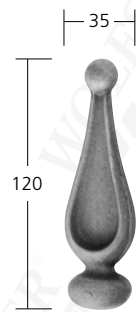

↑ foro
Bohrung
hole
Ø 12,5

41345



↑ foro
Bohrung
hole
Ø 12,5

41351



↑ foro
Bohrung
hole
Ø 12,5

41361



↑ foro
Bohrung
hole
Ø 12,5

41363



↑ foro
Bohrung
hole
Ø 12,5

41371



↑ foro
Bohrung
hole
Ø 12,5

41375

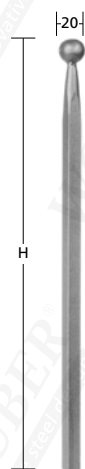

Ø 12 mm

46050 H: 500 mm

46052 H: 1000 mm

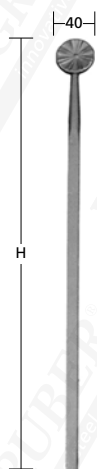

Ø 12 mm

46055 H: 500 mm

46057 H: 1000 mm

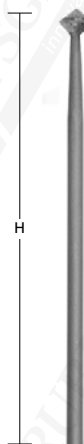

Ø 12 mm

46038 H: 500 mm

46039 H: 1000 mm



Ø 12 mm

46035 H: 500 mm

46037 H: 1000 mm



Ø 12 mm

46060 H: 600 mm

46061 H: 1000 mm

46062 H: 1200 mm

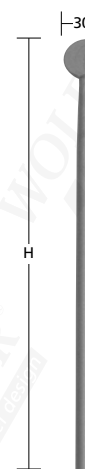

Ø 12 mm

46040 H: 500 mm

46042 H: 1000 mm

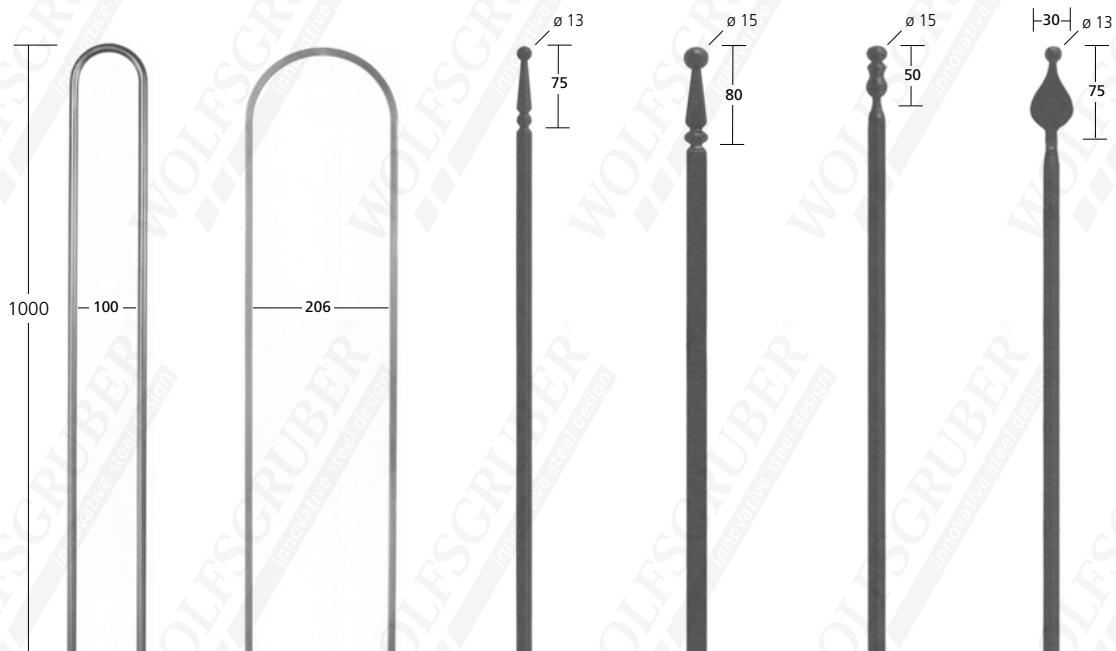

17202 Mat. \varnothing 12 mm

17212 Mat. \varnothing 12 mm

17902 \varnothing 12 mm

17907 \varnothing 12 mm

17912 \varnothing 12 mm

17917 \varnothing 12 mm

17204 Mat. \varnothing 14 mm

17214 Mat. \varnothing 14 mm

17206 Mat. \varnothing 12 mm

17216 Mat. \varnothing 12 mm

17208 Mat. \varnothing 14 mm

17218 Mat. \varnothing 14 mm



17190 \varnothing 12 mm

17191 \varnothing 12 mm

17192 \varnothing 12 mm

17193 \varnothing 12 mm

17194 \varnothing 12 mm

17195 \varnothing 12 mm

17196 \varnothing 12 mm

17197 \varnothing 12 mm



18002 Ø 14 mm
1,50 kg



18004 Ø 14 mm
1,56 kg



18006 Ø 14 mm
1,88 kg

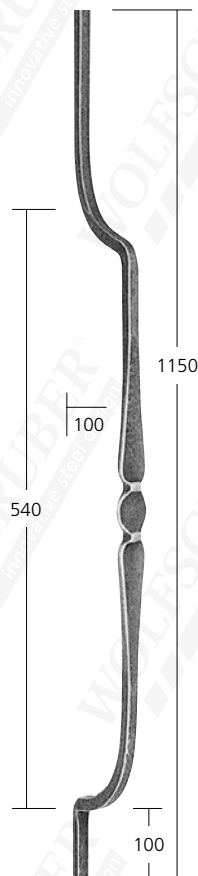

18008 Ø 14 mm
1,88 kg

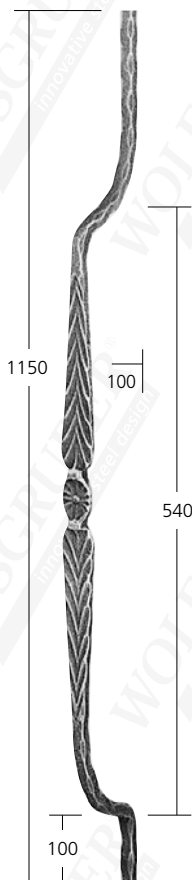

18020 \varnothing 12 mm
1,25 kg



18022 \varnothing 12 mm
1,25 kg



18024 \varnothing 12 mm
1,72 kg

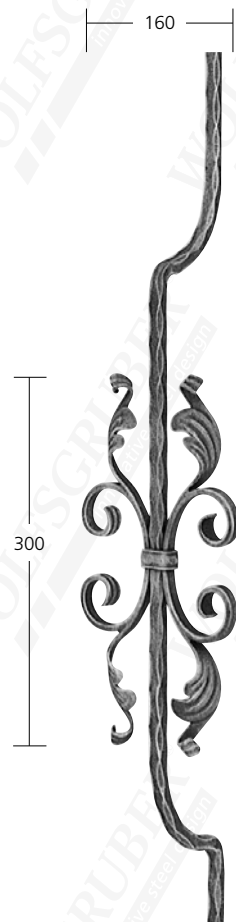

18026 \varnothing 12 mm
1,92 kg



18102 $\varnothing 12$ mm
1,50 kg



18104 $\varnothing 12$ mm
1,50 kg



18110 16x8 mm
2,62 kg

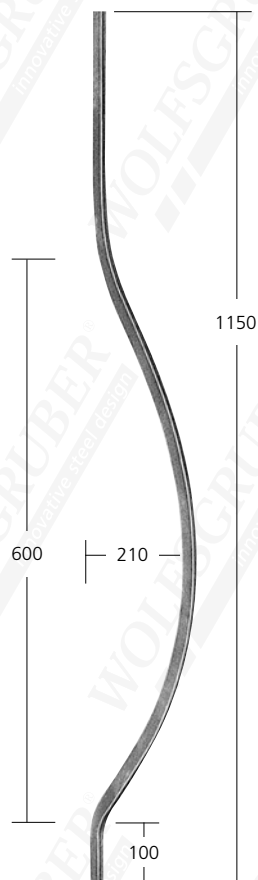

18112 16x8 mm
1,14 kg

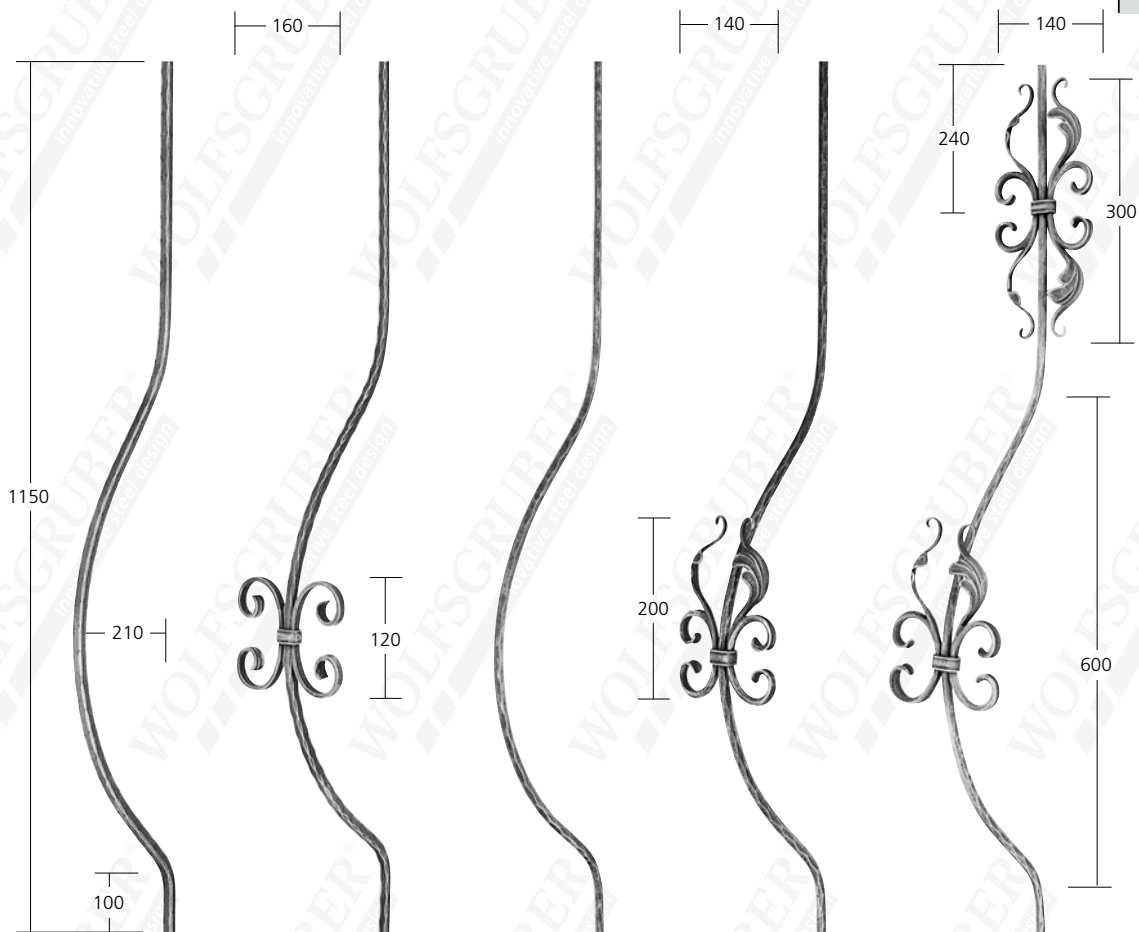

18120 Ø 12 mm
1,40 kg

18122 Ø 12 mm
1,70 kg

18130 Ø 12 mm
1,04 kg

18132 Ø 12 mm
1,48 kg

18134 Ø 12 mm
2,00 kg



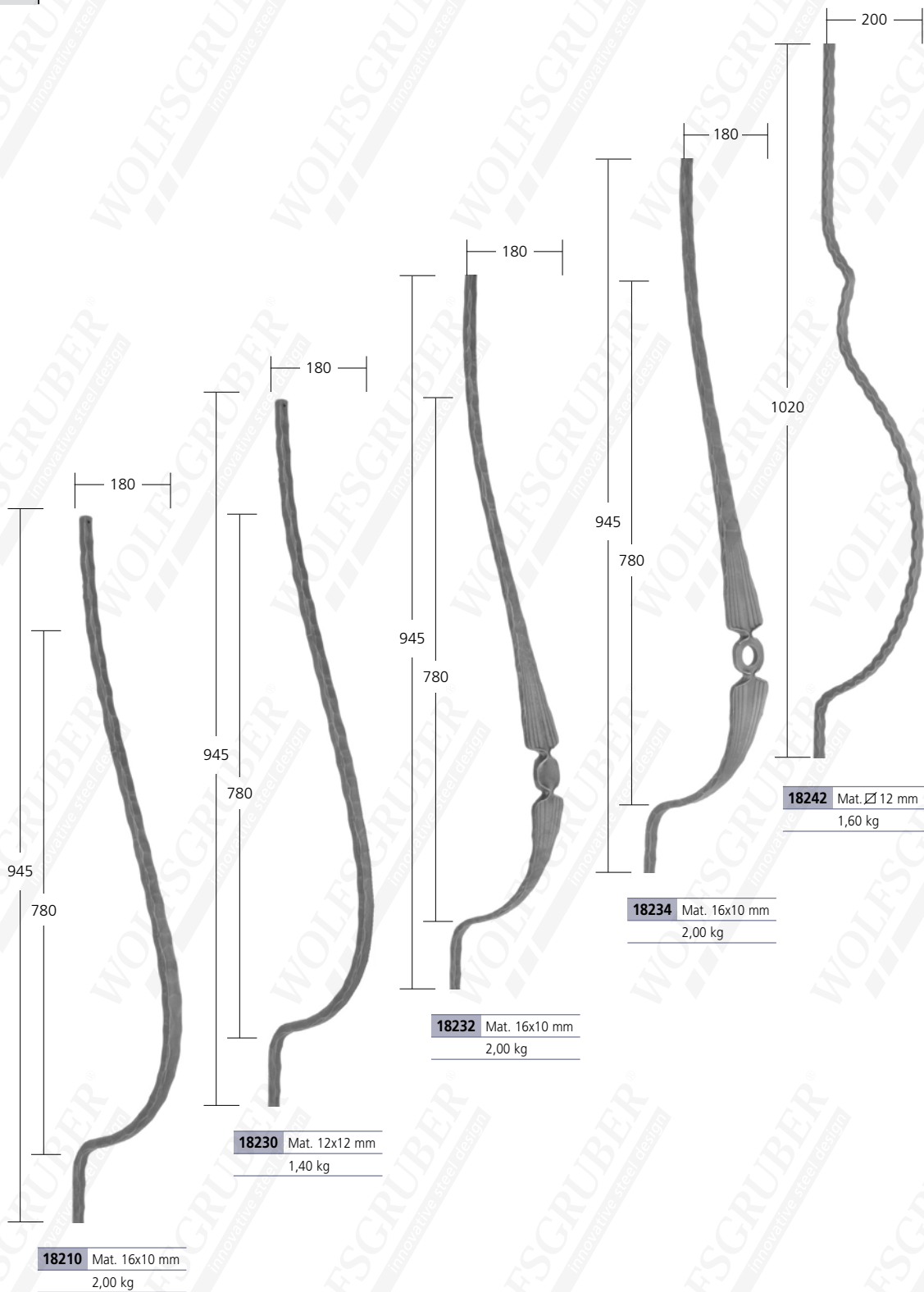

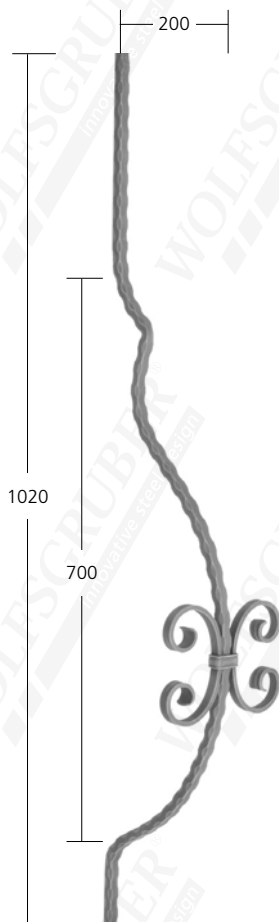

18244 Mat. \varnothing 12 mm
2,00 kg

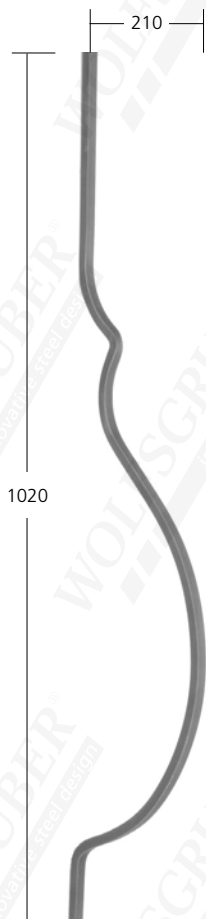

18246 Mat. \varnothing 12 mm
1,60 kg

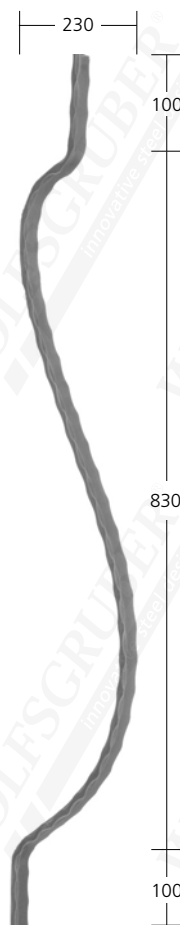

18252 Mat. 20x12 mm
2,15 kg



18254 Mat. 20x12 mm
2,40 kg

BARRE
STANGENMATERIAL
BAR STOCK



WOLFSGRUBER

 innovative steel design

laminati a caldo • warm gewalzt • rolled with heat

20121 Mat. 40x12x6000 mm
3,85 kg/m

20110 Mat. 50x14x3000 mm
4,32 kg/m

20111 Mat. 50x14x6000 mm
4,32 kg/m

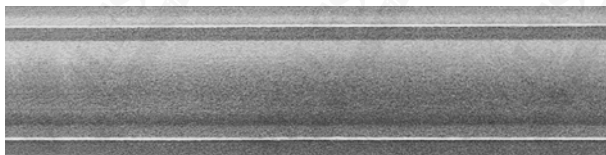

20210 Mat. 50x8x3000 mm
2,55 kg/m

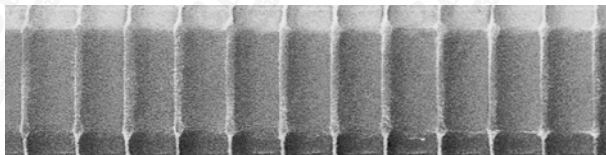

20220 Mat. 50x10x3000 mm
3,69 kg/m

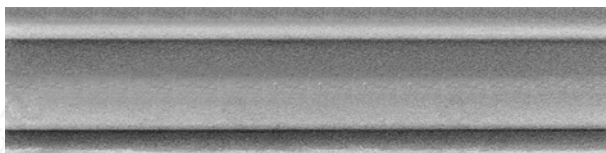

20230 Mat. 40x8x3000 mm
2,47 kg/m

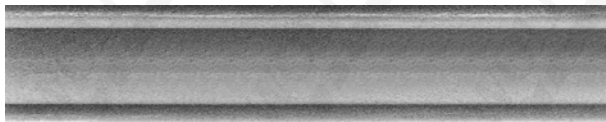

20240 Mat. 40x8x3000 mm
2,49 kg/m

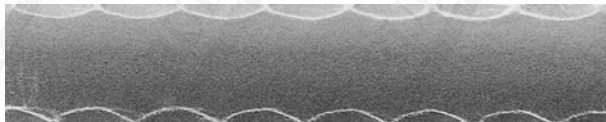

laminati a caldo • warm gewalzt • rolled with heat

20250 Mat. 40x8x3000 mm
2,06 kg/m

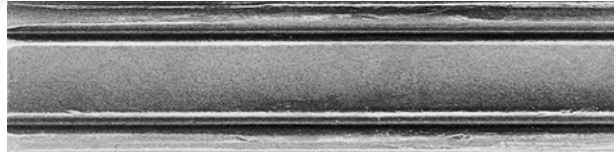

20310 Mat. 50x12x3000 mm
3,68 kg/m

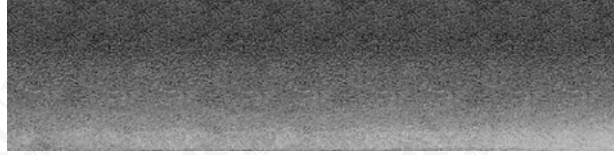

20340 Mat. 40x8x3000 mm
1,972 kg/m

20350 Mat. 40x10x3000 mm
2,37 kg/m

20351 Mat. 40x10x6000 mm
2,37 kg/m

20320 Mat. 40x12x3000 mm
3,01 kg/m

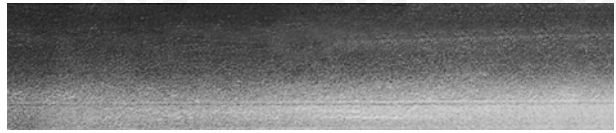

20330 Mat. 30x10x3000 mm
1,89 kg/m

20331 Mat. 30x10x6000 mm
1,89 kg/m



laminato a freddo • kalt gewalzt • rolled without heat

20410 Mat. 40x8x3000 mm
2,36 kg/m

20441 Mat. 40x8x6000 mm
2,36 kg/m

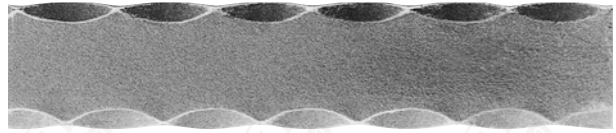

20420 Mat. 40x8x3000 mm
2,36 kg/m

20421 Mat. 40x8x6000 mm
2,36 kg/m

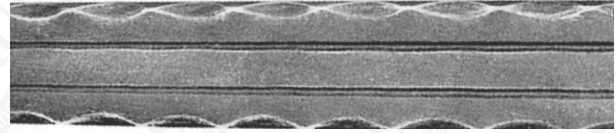

bronzo forgiato • Schmiedebronze • forged bronze



20510 Mat. 54x8x3000 mm
2,69 kg/m



20520 Mat. 54x8x3000 mm
3,09 kg/m



20530 Mat. 42x8x3000 mm
2,30 kg/m



20540 Mat. 45x15x3000 mm
2,81 kg/m



20550 Mat. 50x15x3000 mm
3,83 kg/m

ottone lucidato · Messing hochglanzpoliert · brass highly polished



20700 Mat. \varnothing 42x2x3000 mm

corrimani faggio non trattato · Holzhandläufe Buche natur · handrails beech nature

corrimano in legno
Holzhandlauf
wood handrail



68810 Mat. Ø 42,4x2500 mm



< 27 >

68814 Mat. Ø 49x2500 mm

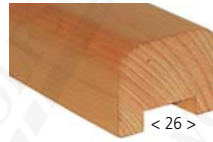

< 26 >

68818 Mat. 45x35x2500 mm



per · für · for
Art. 68814

68815 Mat. 10x25x2500 mm



per tubo
für Rohr Ø 42,4
for tube

68820 Mat. 48,5x24,5x2500 mm



lavorazione finale
Endbearbeitung
finale work

68821

cordone corrimano di iuta · Handlaufseil in Jute · handrail rope in jute



Seil · cordone · rope

20800 Ø 30 mm
0,42 kg/m



nodo · Knoten · knot

20801 Ø 75 mm
0,09 kg

profili di corrimano in PVC · PVC Handlaufprofile · handrail sections in PVC



40 x 8 mm

rulli di 25 m / Rollen à 25 m / roller with 25 m

querzia chiara
Eiche hell
oak light

20810 Mat. 45x19 mm
0,40 kg/m



40 x 8 mm

rosso
Rot
red

20820 Mat. 45x19 mm
0,40 kg/m

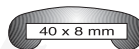

40 x 8 mm

oro
Gold
gold

20830 Mat. 45x19 mm
0,40 kg/m

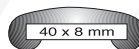

40 x 8 mm

nero
Schwarz
black

20840 Mat. 45x19 mm
0,40 kg/m

laminati a caldo • warm gewalzt • rolled with heat



20121	Mat. 40x12x6000 mm
	3,85 kg/m
20110	Mat. 50x14x3000 mm
	4,32 kg/m
20111	Mat. 50x14x6000 mm
	4,32 kg/m

20122	Mat. 40x12 mm
	1,78 kg
20112	Mat. 50x14 mm
	2,59 kg



20124	Mat. 40x12 mm
	1,78 kg
20114	Mat. 50x14 mm
	2,59 kg

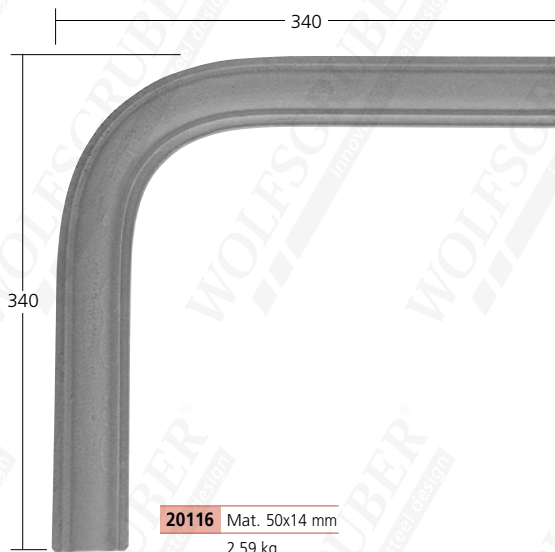

20116	Mat. 50x14 mm
	2,59 kg

laminati a caldo • warm gewalzt • rolled with heat

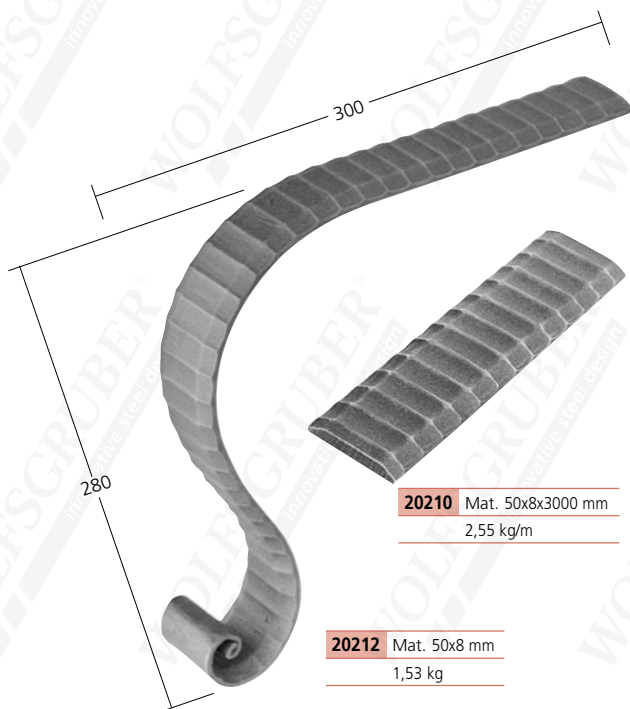

20210 Mat. 50x8x3000 mm
2,55 kg/m

20212 Mat. 50x8 mm
1,53 kg

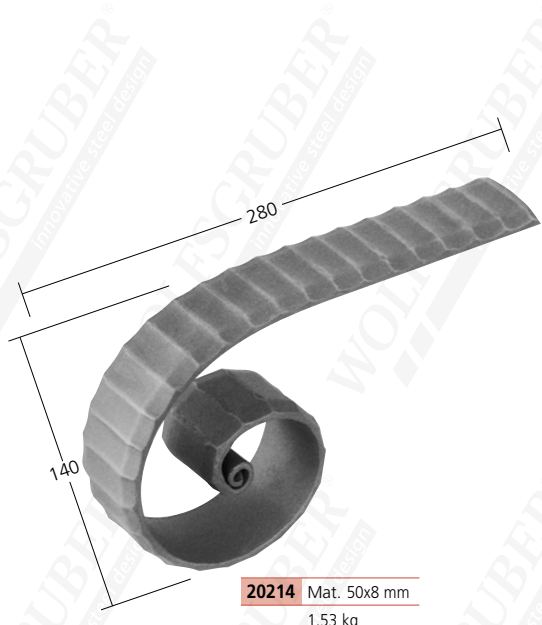
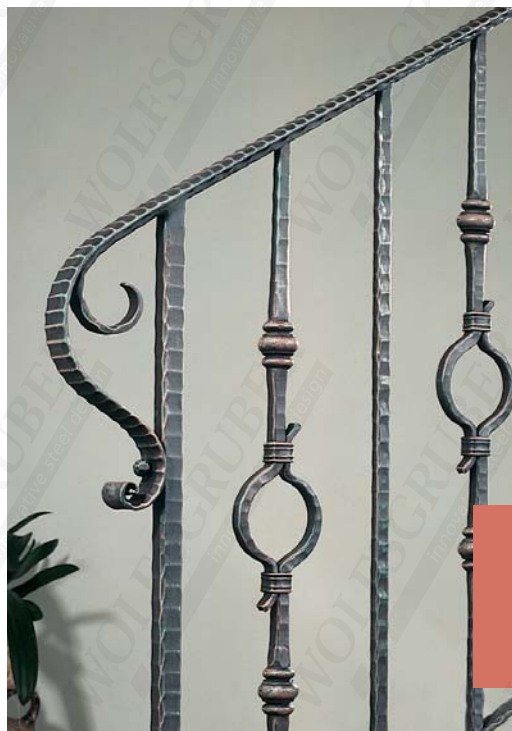

20214 Mat. 50x8 mm
1,53 kg

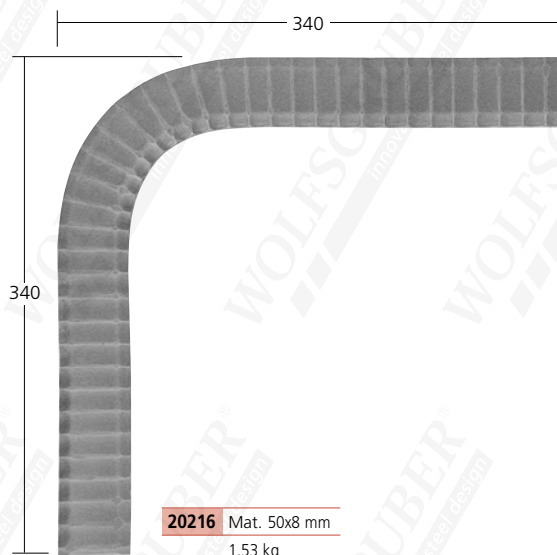

20216 Mat. 50x8 mm
1,53 kg

laminati a caldo • warm gewalzt • rolled with heat

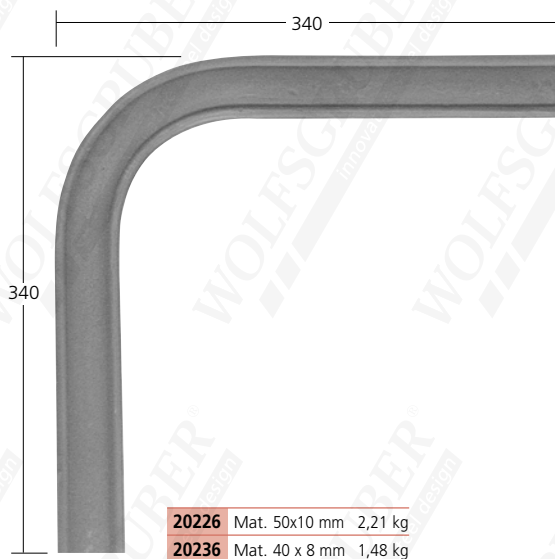
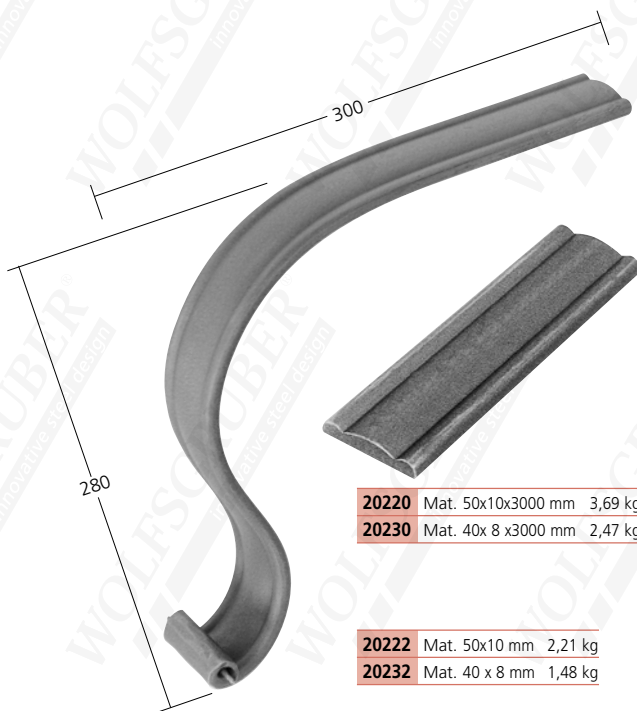

laminati a caldo • warm gewalzt • rolled with heat



20240 Mat. 40x8x3000 mm
2,49 kg/m

20242 Mat. 40x8 mm
1,49 kg

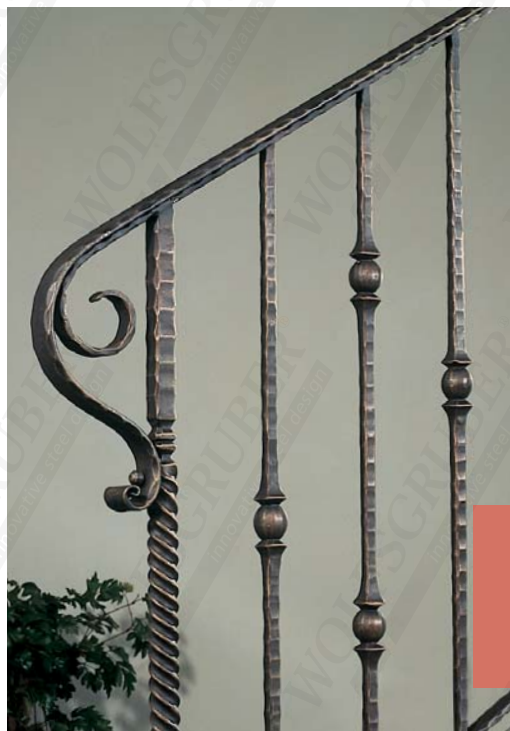

20244 Mat. 40x8 mm
1,49 kg

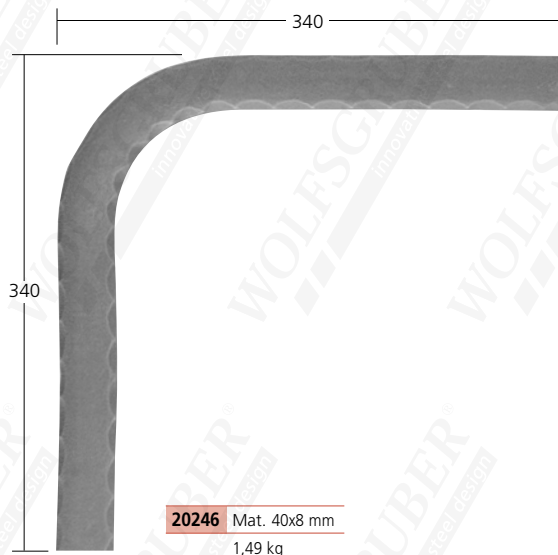

20246 Mat. 40x8 mm
1,49 kg



laminati a caldo • warm gewalzt • rolled with heat

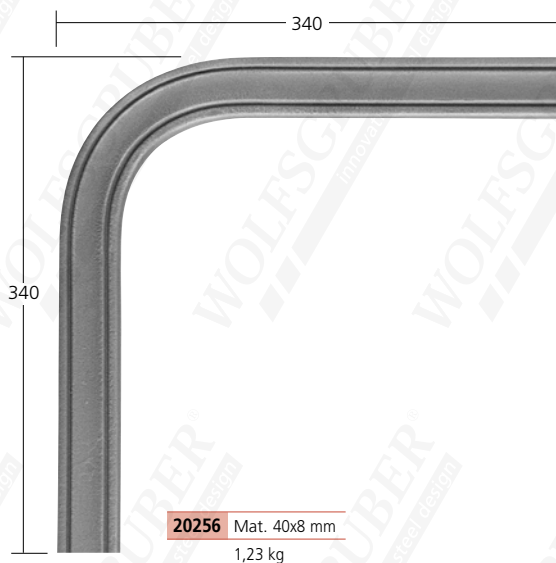
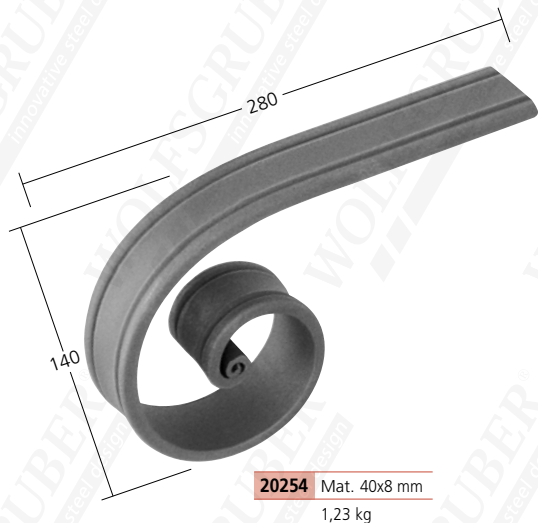

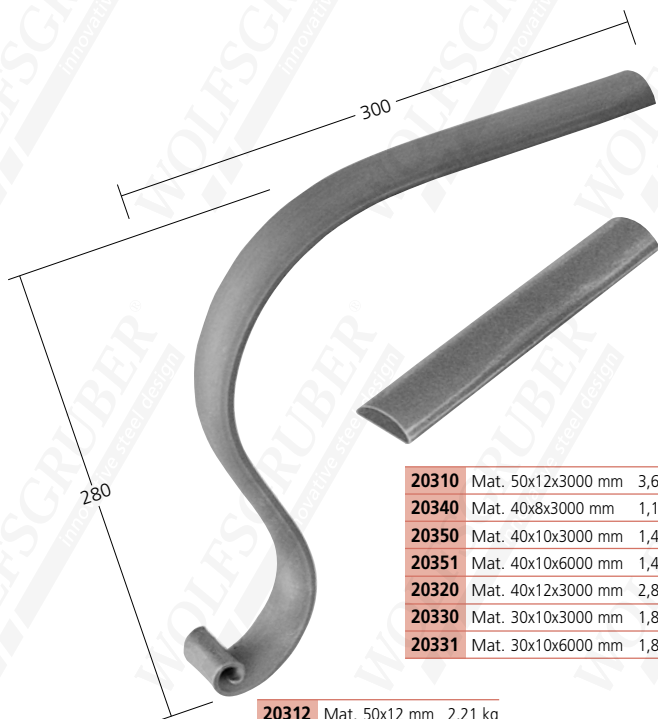

20310	Mat. 50x12x3000 mm	3,68 kg/m
20340	Mat. 40x8x3000 mm	1,18 kg/m
20350	Mat. 40x10x3000 mm	1,40 kg/m
20351	Mat. 40x10x6000 mm	1,40 kg/m
20320	Mat. 40x12x3000 mm	2,86 kg/m
20330	Mat. 30x10x3000 mm	1,89 kg/m
20331	Mat. 30x10x6000 mm	1,89 kg/m

20312	Mat. 50x12 mm	2,21 kg
20342	Mat. 40x8 mm	0,71 kg
20352	Mat. 40x10 mm	0,84 kg
20322	Mat. 40x12 mm	1,72 kg
20332	Mat. 30x10 mm	1,13 kg

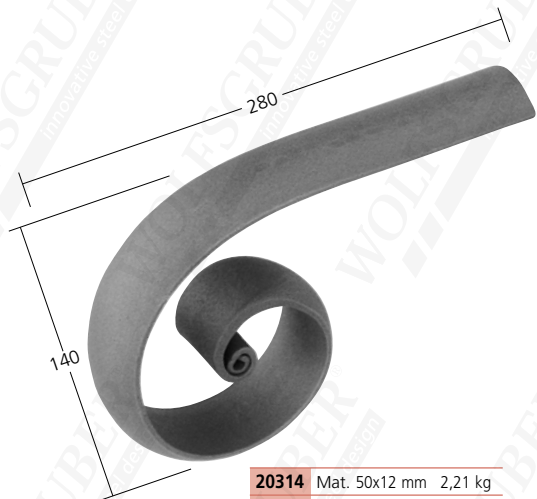
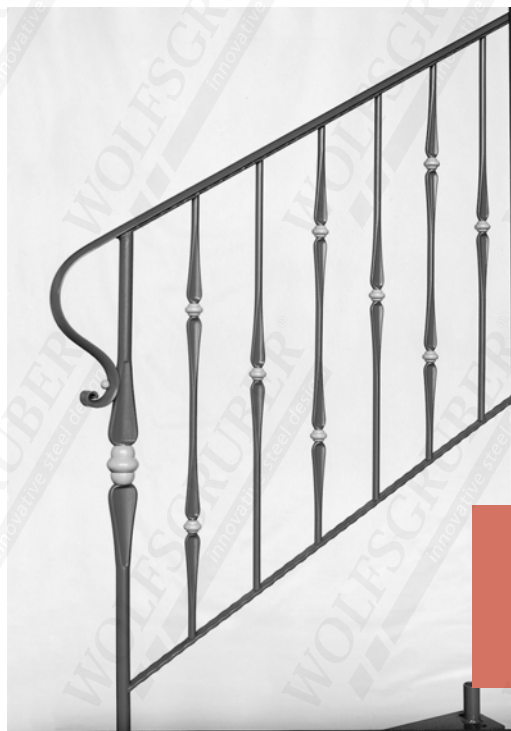

20314	Mat. 50x12 mm	2,21 kg
20344	Mat. 40x8 mm	0,71 kg
20354	Mat. 40x10 mm	0,84 kg
20324	Mat. 40x12 mm	1,72 kg
20334	Mat. 30x10 mm	1,13 kg

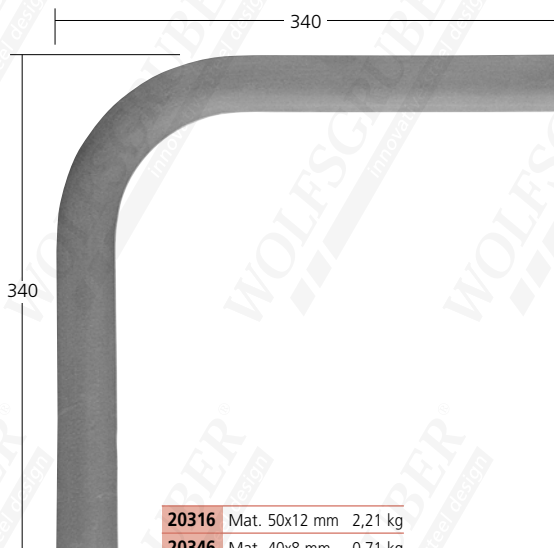

20316	Mat. 50x12 mm	2,21 kg
20346	Mat. 40x8 mm	0,71 kg
20356	Mat. 40x10 mm	0,84 kg
20326	Mat. 40x12 mm	1,72 kg
20336	Mat. 30x10 mm	1,13 kg



laminati a freddo • kalt gewalzt • rolled without heat

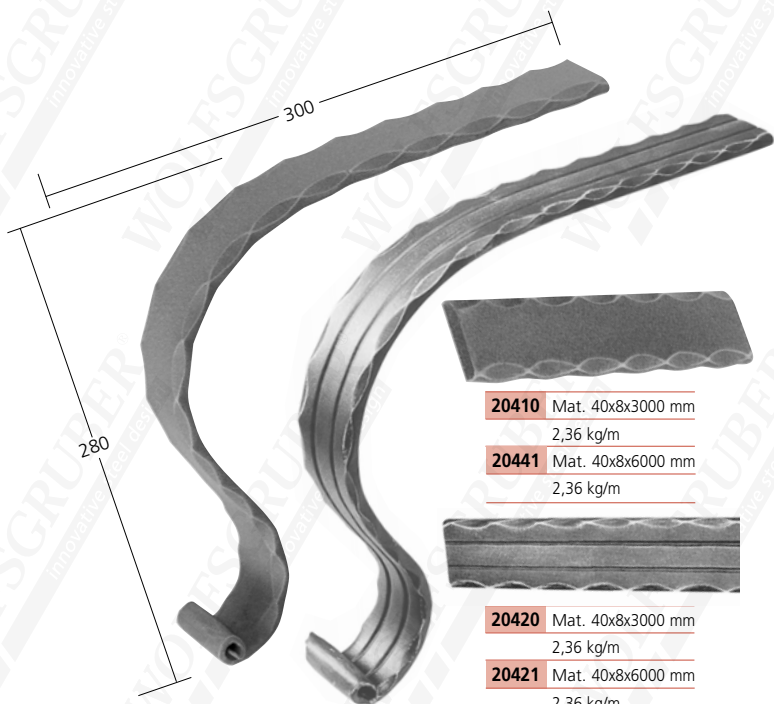

20412 Mat. 40x8 mm
1,42 kg

20422 Mat. 40x8 mm
1,42 kg

20410 Mat. 40x8x3000 mm
2,36 kg/m
20441 Mat. 40x8x6000 mm
2,36 kg/m

20420 Mat. 40x8x3000 mm
2,36 kg/m
20421 Mat. 40x8x6000 mm
2,36 kg/m

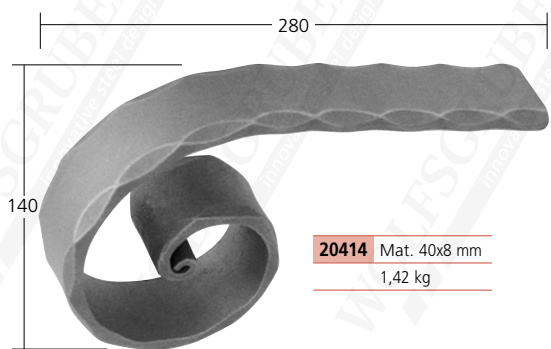

20414 Mat. 40x8 mm
1,42 kg

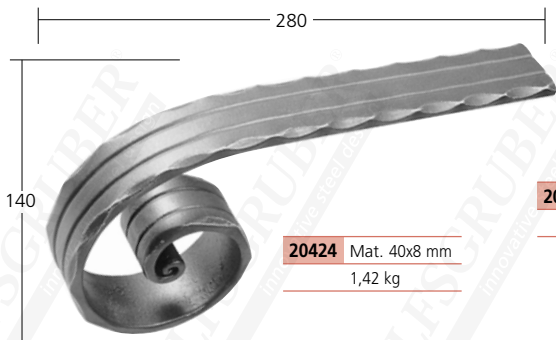

20424 Mat. 40x8 mm
1,42 kg

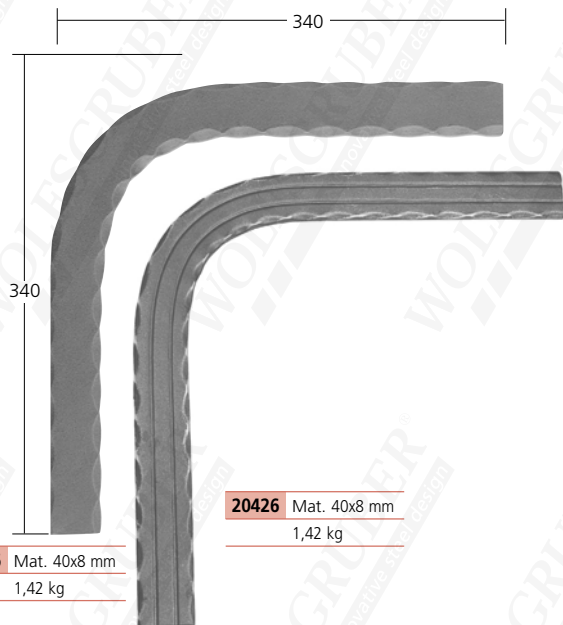

20426 Mat. 40x8 mm
1,42 kg

20416 Mat. 40x8 mm
1,42 kg

laminati a freddo • kalt gewalzt • rolled without heat

20910 Ø 30x2800 mm
3,77 kg/m

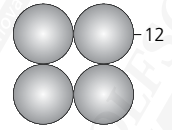
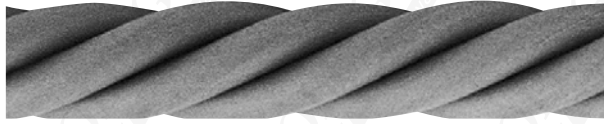

20920 Ø 20x2800 mm
1,77 kg/m

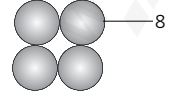

20930 Ø 15x2800 mm
1,06 kg/m

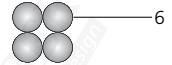

piani di fondo · Untergurte · planes bellow

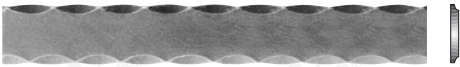

21010 Mat. 25x8x3000 mm 1,47 kg/m
21020 Mat. 30x8x3000 mm 1,76 kg/m
21030 Mat. 30x10x3000 mm 2,26 kg/m
21031 Mat. 30x10x6000 mm 2,26 kg/m



21016 Mat. 25x8 mm 0,88 kg
21026 Mat. 30x8 mm 1,06 kg
21036 Mat. 30x10 mm 1,36 kg

spigoli martellati a due lati
Kanten beidseitig gehämmert
edges hammered on both sides

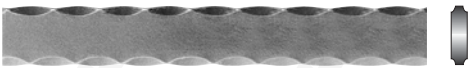

21210 Mat. 25x8x3000 mm 1,43 kg/m
21220 Mat. 30x8x3000 mm 1,80 kg/m
21230 Mat. 30x10x3000 mm 2,29 kg/m
21240 Mat. 30x12x3000 mm 2,74 kg/m

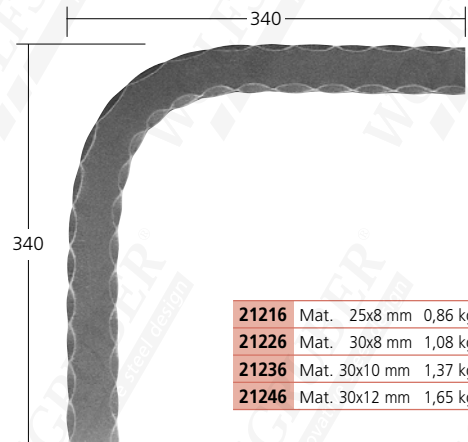

21216 Mat. 25x8 mm 0,86 kg
21226 Mat. 30x8 mm 1,08 kg
21236 Mat. 30x10 mm 1,37 kg
21246 Mat. 30x12 mm 1,65 kg



laminati a caldo • warm gewalzt • rolled with heat



bronzo da forgia
Schmiedebronze
bronze forged



20510 Mat. 54x8x3000 mm
2,69 kg/m

20512 Mat. 54x8 mm
1,61 kg



20514 Mat. 54x8 mm
1,61 kg

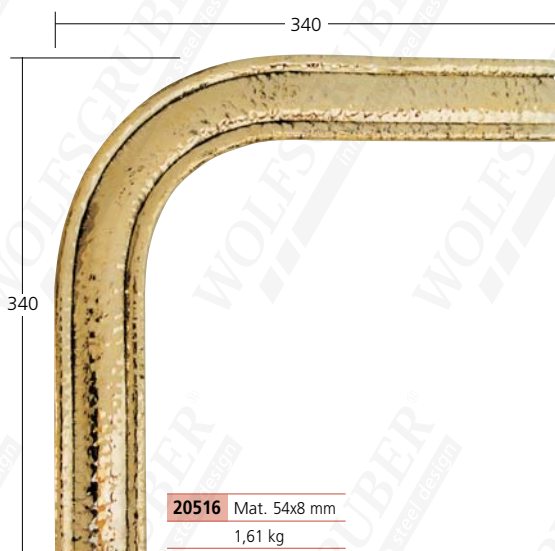

20516 Mat. 54x8 mm
1,61 kg

bronzo da forgia
Schmiedebronze
bronze forged



20520	Mat. 54x8x3000 mm	3,09 kg/m
20530	Mat. 42x8x3000 mm	2,30 kg/m

20522	Mat. 54x8 mm	1,85 kg
20532	Mat. 42x8 mm	1,38 kg



20524	Mat. 54x8 mm	1,85 kg
20534	Mat. 42x8 mm	1,38 kg



20526	Mat. 54x8 mm	1,85 kg
20536	Mat. 42x8 mm	1,38 kg



laminati a freddo • kalt gewalzt • rolled without heat



20542 Mat. 45x15 mm
1,69 kg

20552 Mat. 50x15 mm
2,30 kg

20540 Mat. 45x15x3000 mm
2,81 kg/m



20550 Mat. 50x15x3000 mm
3,83 kg/m



20544 Mat. 45x15 mm
1,69 kg

20554 Mat. 50x15 mm
2,30 kg



22610 Mat. Ø 12 mm
0,62 kg



22620 Mat. Ø 14 mm
0,74 kg



22630 Mat. Ø 14 mm
0,8 kg



22640 Loch
foro - hole Ø 30 mm
0,68 kg

sostegni per
cordoni
Seilträger
supporting
guides for
ropes

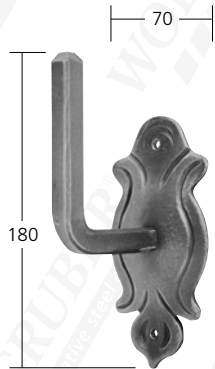

22650 Mat. 12x12 mm
0,46 kg

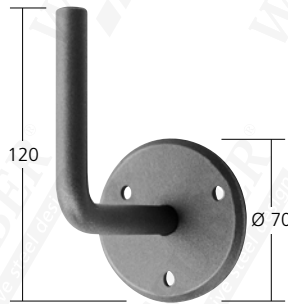

22710 Mat. Ø 14 mm 0,28 kg
22712 Mat. Ø 12 mm 0,24 kg



22720 Mat. Ø 14 mm
0,28 kg



22730 Mat. Ø 14 mm
0,28 kg



22660 Mat. Ø 12 mm
0,85 kg



für Rohr
per tubo
for hole
22735 Ø 42,4 mm



Mat.	kg	loch foro hole
22810	76x1.5x12	0,06 Ø 14
22812	76x1.5x12	0,06 Ø 12



Mat.	kg	loch foro hole
22820	70x5	0,06 Ø 14
22822	70x5	0,06 Ø 12



TUBI ANGOLARI • VIERKANTROHRE • SQUARE TUBES

martellati a spigolo • Kanten gehämmert • edges hammered

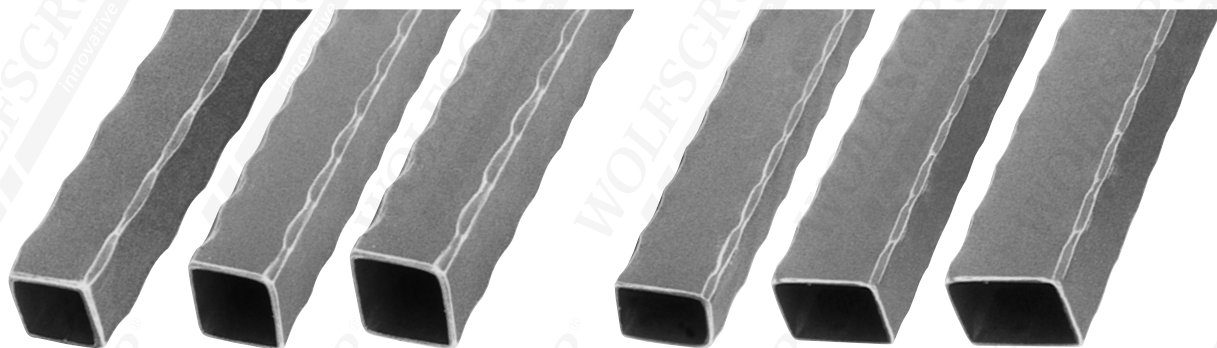

	Mat.	kg/m
23120	20x20x2x3000	1,13
23121	20x20x2x6000	1,13
23125	25x25x2,5x3000	1,47
23126	25x25x2,5x6000	1,47
23130	30x30x2,5x3000	1,76
23131	30x30x2,5x6000	1,76
23140	40x40x2,5x3000	3,60
23141	40x40x2,5x6000	3,60
23151	50x50x2,5x6000	3,58
23160	60x60x2,5x3000	5,36
23161	60x60x2,5x6000	5,36
23180	80x80x2,5x3000	7,30
23181	80x80x2,5x6000	7,30
23190	100x100x3x3000	12,05
23191	100x100x3x6000	12,05

	Mat.	kg/m
23230	30x20x2x3000	1,47
23231	30x20x2x6000	1,47
23240	40x20x2x3000	7,76
23241	40x20x2x6000	7,76
23245	40x30x2,5x3000	2,11
23246	40x30x2,5x6000	2,11
23250	50x30x2,5x3000	3,97
23251	50x30x2,5x6000	3,97
23255	50x40x2,5x3000	3,97
23256	50x40x2,5x6000	3,97
23260	60x40x2,5x3000	4,45
23261	60x40x2,5x6000	4,45
23280	80x40x2,5x3000	5,36
23281	80x40x2,5x6000	5,36
23291	100x40x2,5x6000	5,30
23296	100x50x3x6000	6,78



barre da 6 metri su richiesta • 6 meter Stangen auf Anfrage • 6 meters rods on request

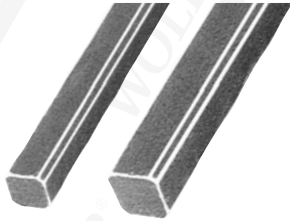

	Mat.	kg/m
24012	12x12x3000	1,10
24014	14x14x3000	1,50
24016	16x16x3000	1,89

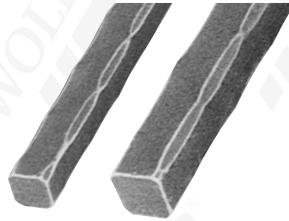

	Mat.	kg/m
24112	12x12x3000	1,10
24113	12x12x6000	1,10
24114	14x14x3000	1,50
24115	14x14x6000	1,50
24116	16x16x3000	1,89
24117	16x16x6000	1,89
24120	20x20x3000	2,98
24125	25x25x3000	4,90
24130	30x30x3000	7,10

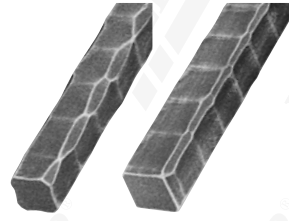

	Mat.	kg/m
24212	12x12x3000	1,10
24214	14x14x3000	1,38
24216	16x16x3000	1,89
24220	20x20x3000	2,98
24225	25x25x3000	4,60
24230	30x30x3000	7,10

forgiato a 4 lati
e spigliato
Fläche und Kante
gehämmert
surface and edges
hammered

cimase per cancelli su richiesta • Schweif und Segmentbögen auf Anfrage • ornaments for gates on request

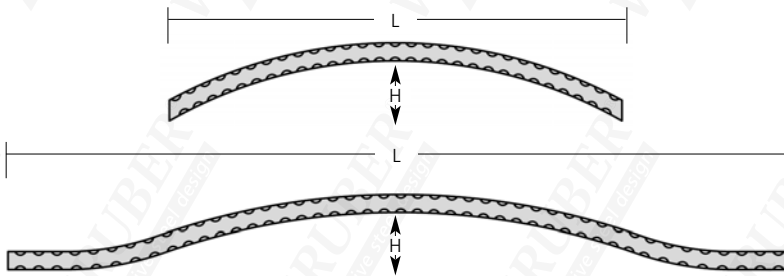

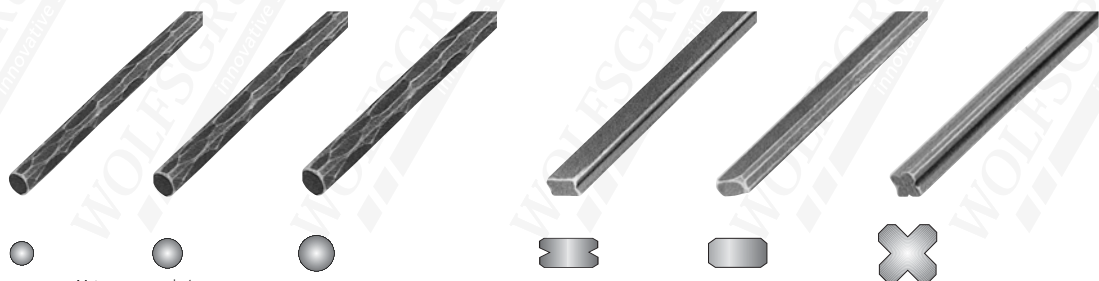

	Mat.	kg/m
24408	Ø 8x3000	0,36
24410	Ø 10x3000	0,56
24412	Ø 12x3000	0,80
24414	Ø 14x3000	1,21
24416	Ø 16x3000	1,58
24420	Ø 20x3000	2,47
24425	Ø 25x3000	3,85

24516	Mat. 16x8x3000 mm	0,95 kg/m
--------------	-------------------	-----------

24616	Mat. 16x8x3000 mm	0,97 kg/m
--------------	-------------------	-----------

24712	Mat. 12x12x3000 mm	1,01 kg/m
--------------	--------------------	-----------

profili sagomati · Zierprofile · ornamental sections

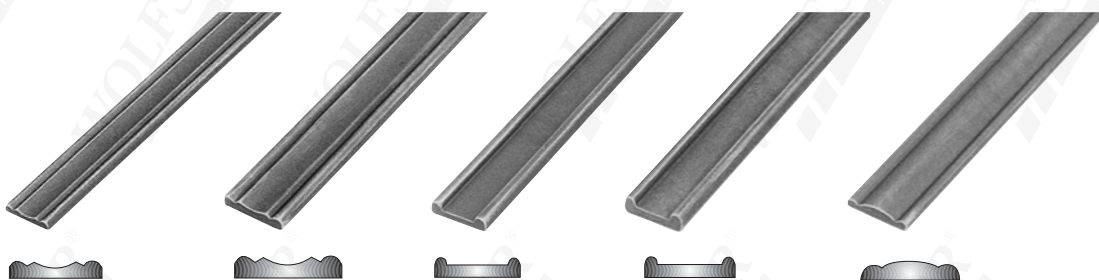

25022	22x4x3000 mm	0,65 kg/m
--------------	--------------	-----------

25033	33x7x3000 mm	1,53 kg/m
--------------	--------------	-----------

25125	25x8x3000 mm	1,09 kg/m
25126	25x8x6000 mm	

25130	30x8x3000 mm	1,25 kg/m
25131	30x8x6000 mm	

25330	30x6x3000 mm	1,06 kg/m
--------------	--------------	-----------

25141	40x8x6000 mm	1,59 kg/m
--------------	--------------	-----------



25150	Mat. 45x3x2000 mm	1,55 kg/m
--------------	-------------------	-----------



25622	Mat. 22x4x3000 mm	0,65 kg/m
--------------	-------------------	-----------

25630	Mat. 30x6x3000 mm	1,11 kg/m
--------------	-------------------	-----------

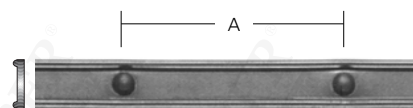

	Mat.	A	kg/m
25142	25x8x2000	125	2,18
25143	25x8x3000	125	2,18
25144	30x8x2000	125	2,50
25145	30x8x3000	125	2,50

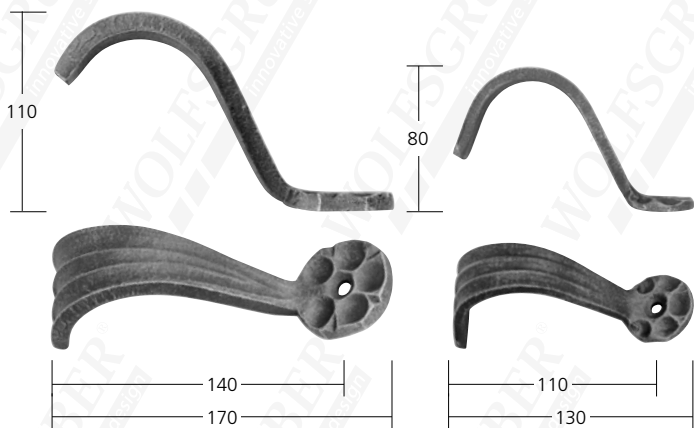

48010 Mat. 10 mm
0,50 kg

48015 Mat. 6 mm
0,25 kg



48020 Mat. 7 mm
0,30 kg



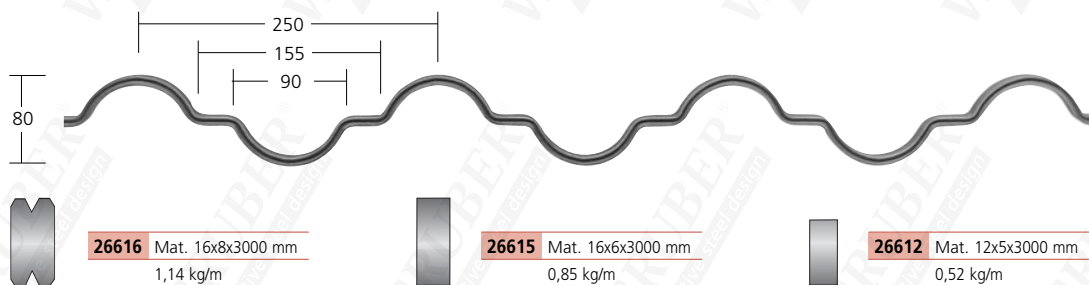
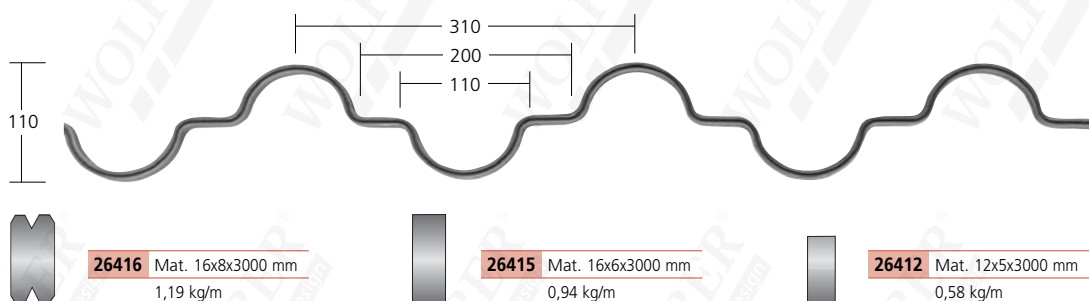
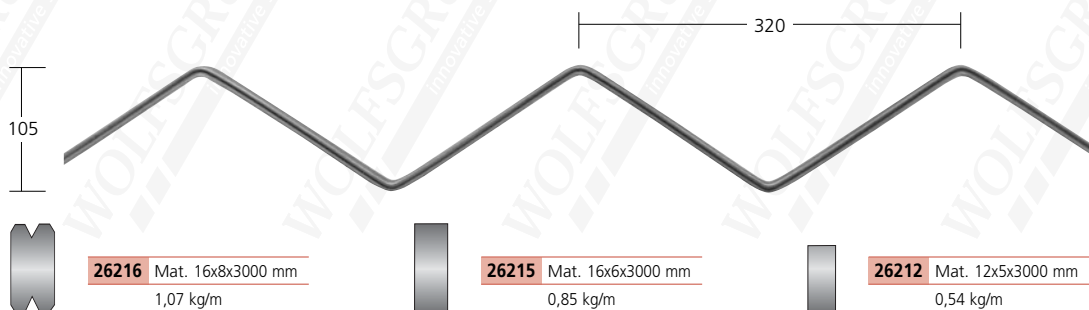

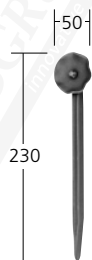

26716 Mat. 16x8 mm
0,22 kg



26715 Mat. 16x6 mm
0,18 kg



26712 Mat. 12x5 mm
0,12 kg

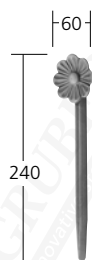

26816 Mat. 16x8 mm
0,28 kg



26815 Mat. 16x6 mm
0,24 kg



26812 Mat. 12x5 mm
0,18 kg

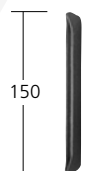

26916 Mat. 16x8 mm
0,13 kg



26915 Mat. 16x6 mm
0,10 kg



26912 Mat. 12x5 mm
0,07 kg

esempi d'impiego · Anwendungsbeispiele · examples of application



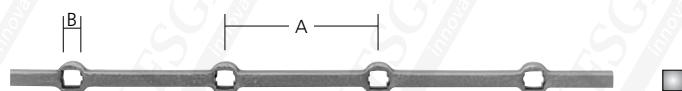

	A	B	∅	lunghezza Länge length	kg
27012	120	12,5	12	2000	2,15
27014	140	14,5	14	2000	2,92
27016	150	16,5	16	2000	3,82

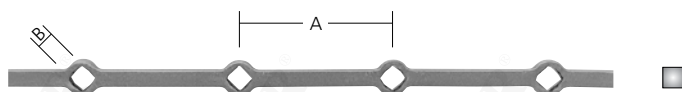

	A	B	∅	lunghezza Länge length	kg
27112	120	12,5	12	2000	2,15
27114	140	14,5	14	2000	2,92
27116	150	16,5	16	2000	3,82

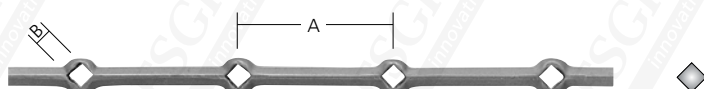

	A	B	∅	lunghezza Länge length	kg
27214	140	14,5	14	2000	2,92
27216	150	16,5	16	2000	3,82

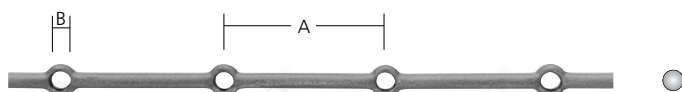

	A	B	∅	lunghezza Länge length	kg
27312	120	12,5	12	2000	1,78
27314	140	14,5	14	2000	2,42
27316	150	16,5	16	2000	3,15

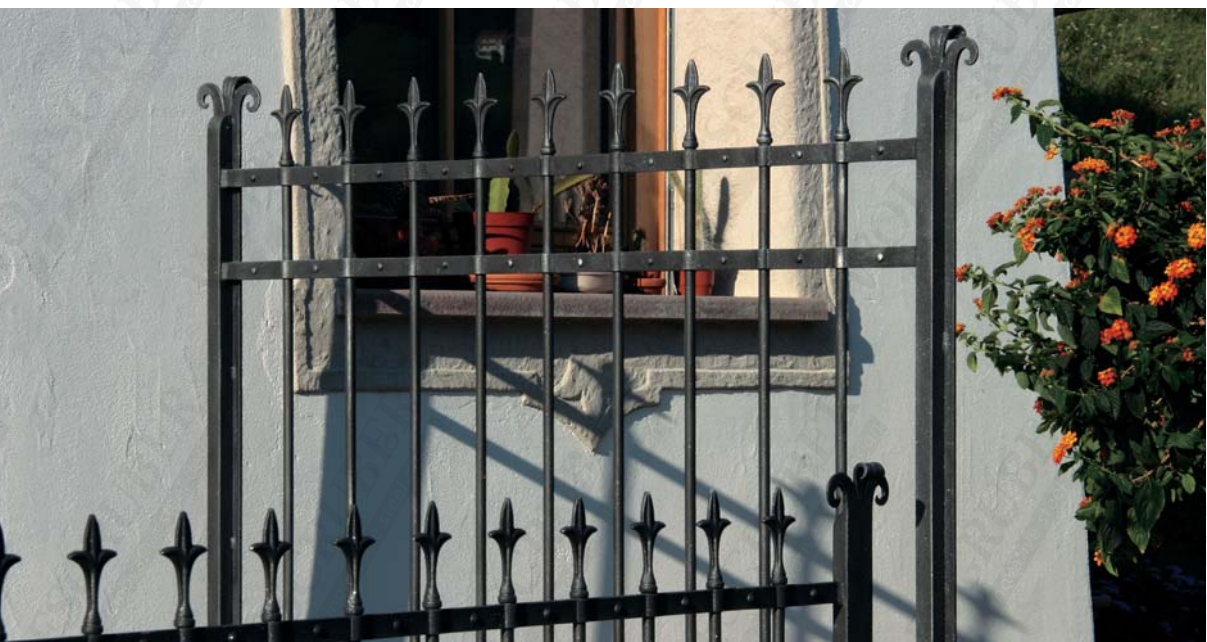

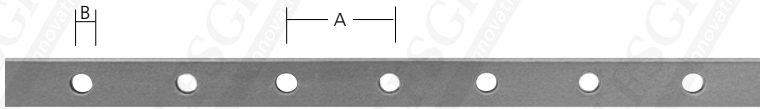

	Mat.	A	B	lunghezza Länge length	kg
27502	25x6	60	12,5	2000	2,30
27504	25x6	60	12,5	3000	3,50
27522	30x8	60	12,5	2000	3,60
27524	30x8	60	12,5	3000	5,60

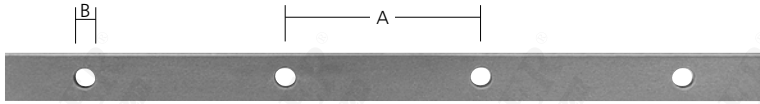

	Mat.	A	B	lunghezza Länge length	kg
27506	25x6	120	12,5	2000	2,30
27508	25x6	120	12,5	3000	3,50
27510	25x8	120	12,5	2000	3,00
27511	25x8	120	12,5	3000	4,50
27526	30x8	120	12,5	2000	3,60
27528	30x8	120	12,5	3000	5,60
27413	30x8	125	12,5	2000	3,60
27415	30x8	125	14,5	2000	3,62

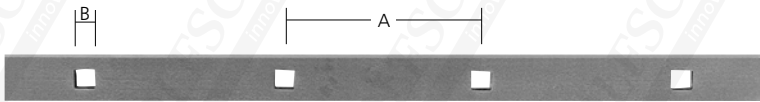

	Mat.	A	B	lunghezza Länge length	kg
27410	25x8	120	12,5	2000	3,00
27411	25x8	120	12,5	3000	4,50
27412	25x8	130	12,5	2000	3,00
27414	30x8	132	14,5	2000	3,57

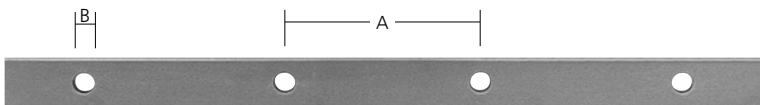

	Mat.	A	B	lunghezza Länge length	kg
27512	25x8	130	12,5	2000	3,03
27514	30x8	132	14,5	2000	3,62



	Mat.	A	B	lunghezza Länge length	kg
27606	25x5	60	12-14	2000	2,00

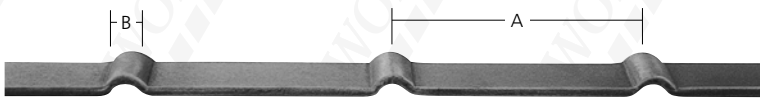

	Mat.	A	B	lunghezza Länge length	kg
27612	25x5	120	12-14	2000	2,00

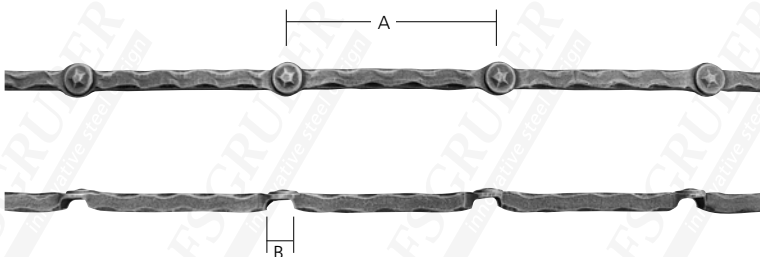

	Mat.	A	B	lunghezza Länge length	kg
27714	14x14	125	14,5	2000	3,08

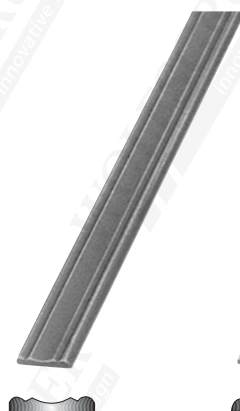

25022 22x4x3000 mm
0,65 kg/m



28112 12x3x3000 mm
0,25 kg/m



28114 14x3x3000 mm
0,30 kg/m

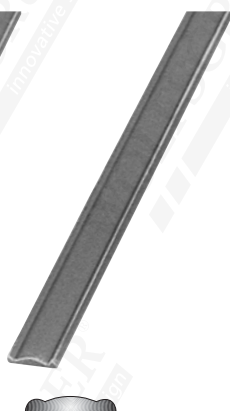

28116 16x4x3000 mm
0,46 kg/m



28120 20x4x3000 mm
0,53 kg/m



28214 14x4x2000 mm
28215 14x4x4000 mm
0,41 kg/m



28314 14x4x2000 mm
28315 14x4x4000 mm
0,37 kg/m

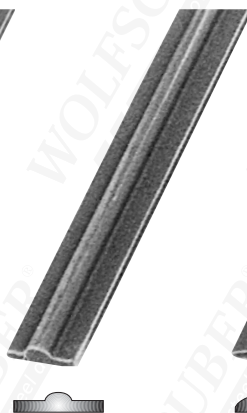

28318 18x5x2000 mm
28319 18x5x4000 mm
0,51 kg/m

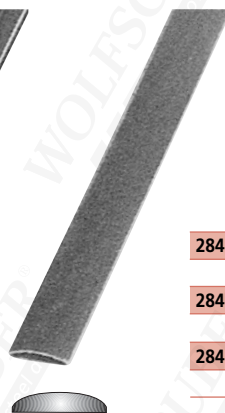

28417 14x4x4000 mm
0,33 kg/m
28414 16x5x2000 mm
0,28 kg/m
28414S 16x3x2000 mm
0,20 kg/m







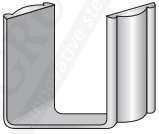





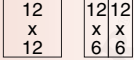







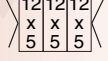
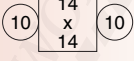

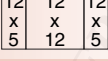





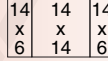
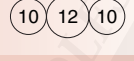

28816 16x4x3000 mm
0,41 kg/m

28820 20x4x3000 mm
0,57 kg/m

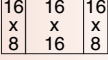
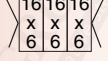
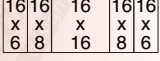

materiale tenero ricotto
Sondermaterial weichgeglüht · special soft-annealed material

Art.	giunzione del materiale: Materialverbindung: material connection:	impiego: Anwendung: application:	Art.	giunzione del materiale: Materialverbindung: material connection:	impiego: Anwendung: application:
Art. 28114  14x3 mm			Art. 28116  16x4 mm		
29402			29636		Art. 26416 Art. 26616
29404		Art. 26412 Art. 26612	29637		Art. 26216
29405		Art. 26212	29640		Art. 26416 Art. 26616
29412		Art. 26412 Art. 26612	29641		Art. 26216
29413		Art. 26212	29660		
29416			29672		
29418			29673		
Art. 28116  16x4 mm			Art. 28120  20x4 mm		
29600			29676		
29620			29677		
29622			29680		
29626		Art. 26415 Art. 26615	Art. 28120  20x4 mm		
29627		Art. 26215	29850		
29630		Art. 26415 Art. 26615	29852		
29631		Art. 26215	29856		Art. 32430
} congiunzioni di piatto piegato con raggio stretto { } Verbindungen von geknicktem Flachmaterial { } connections of flat iron curves with small radius {			29890		
			29894		

confezione da 100 pezzi · 100er-Pack · 100 pcs.

ELEMENTI ORNAMENTALI
ZIERELEMENTE
ORNAMENTAL ELEMENTS



WOLFSGRUBER



innovative steel design

barocco rustico · Ländliches Barock · country baroque

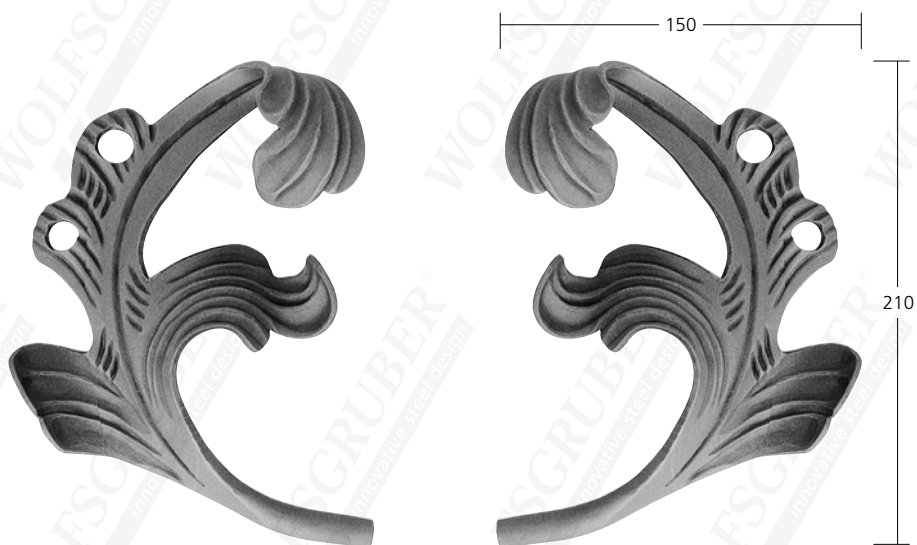

30010 Mat. 4 mm **30011**

0,48 kg

sede
Ansatz - lug Ø 12 mm



30012 Mat. 4 mm **30013**

0,36 kg

sede
Ansatz - lug Ø 12 mm

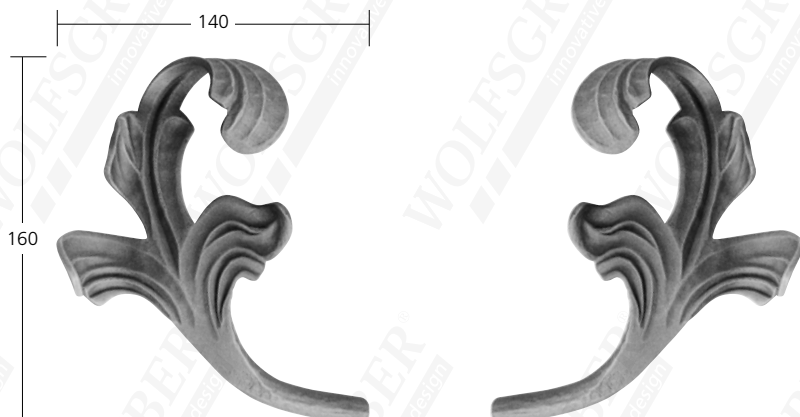

30016 Mat. 4 mm **30017**

0,31 kg

sede
Ansatz - lug Ø 12 mm

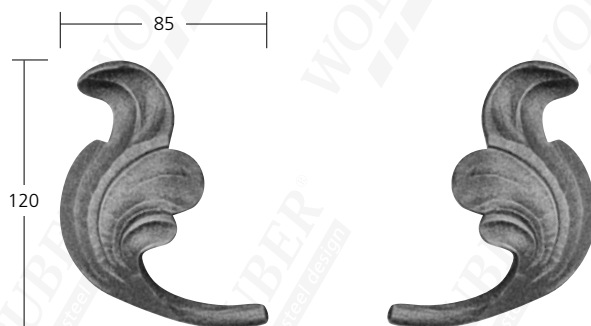

30018 Mat. 4 mm **30019**

0,16 kg

sede
Ansatz - lug Ø 12 mm

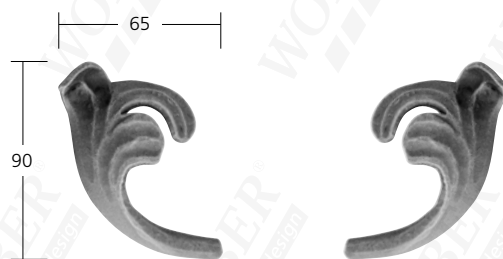

30020 Mat. 4 mm **30021**

0,12 kg

sede
Ansatz - lug Ø 10 mm

barocco rustico · Ländliches Barock · country baroque

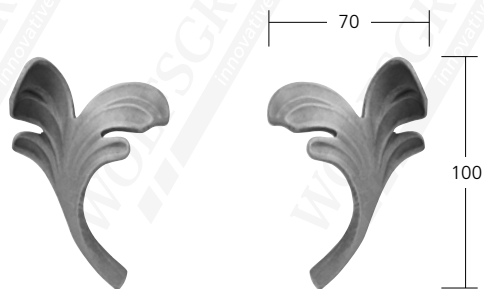

30210 Mat. 3 mm **30211**

0,08 kg

sede
Ansatz - lug Ø 10 mm

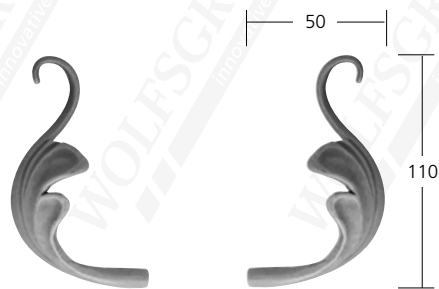

30214 Mat. 3 mm **30215**

0,06 kg

sede
Ansatz - lug Ø 10 mm

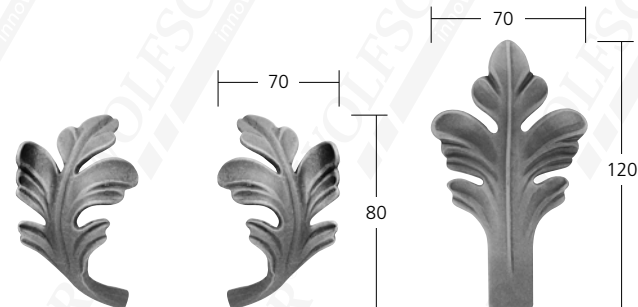

30218 Mat. 3 mm **30219**

0,10 kg

sede
Ansatz - lug Ø 10 mm

30220 Mat. 3 mm

0,10 kg

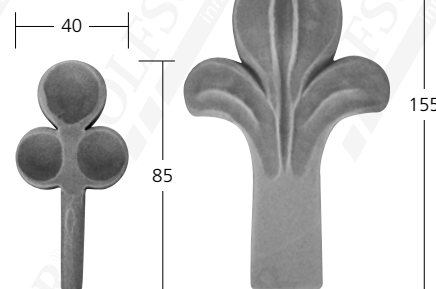

30224 Mat. 5 mm

0,06 kg

sede
Ansatz - lug Ø 10 mm

30227 Mat. 4 mm

0,18 kg



30226 Mat. 4 mm

0,16 kg

sede
Ansatz - lug Ø 12 mm

30250 Mat. 4 mm

0,25 kg

sede
Ansatz - lug Ø 12 mm

30254 Mat. 4 mm

0,30 kg

sede
Ansatz - lug Ø 12 mm

30260 Mat. 4 mm

0,24 kg

30264 Mat. 5 mm

0,28 kg



30272



30274



30276



30278



30286



30284

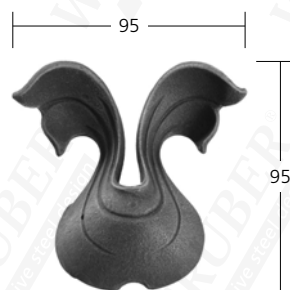

30280

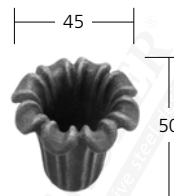

30282

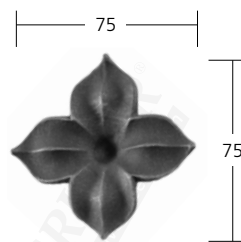

30288

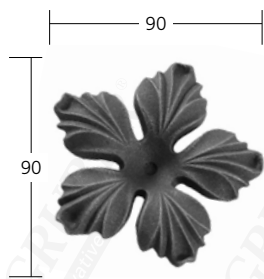

30290

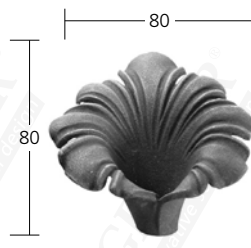

30292



barocco rustico · Ländliches Barock · country baroque

martellato · gehämmert · hammered

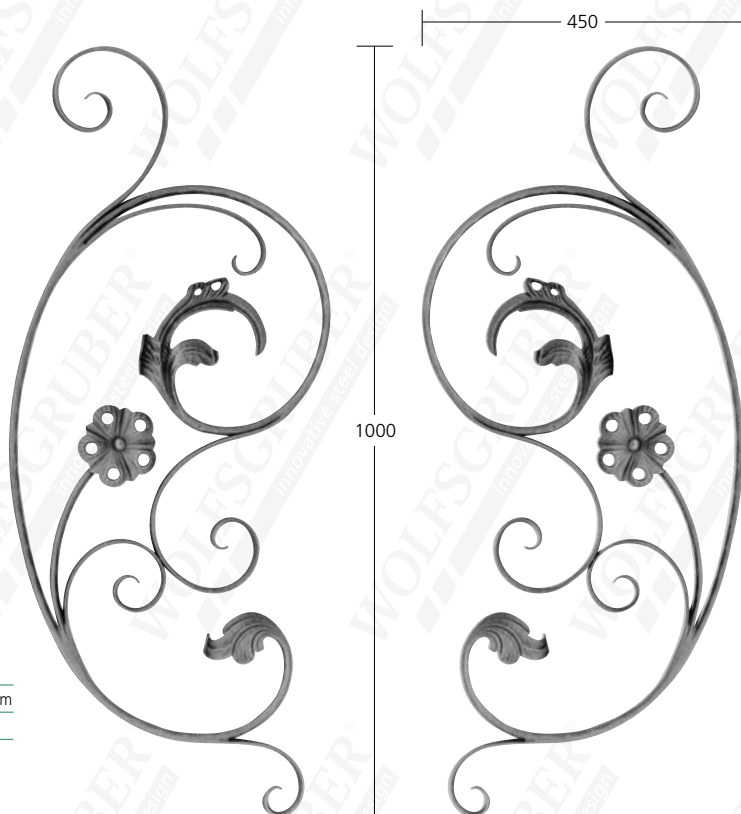

31010 Mat. Ø 12 mm
2,90 kg

31011 Mat. Ø 12 mm
2,90 kg

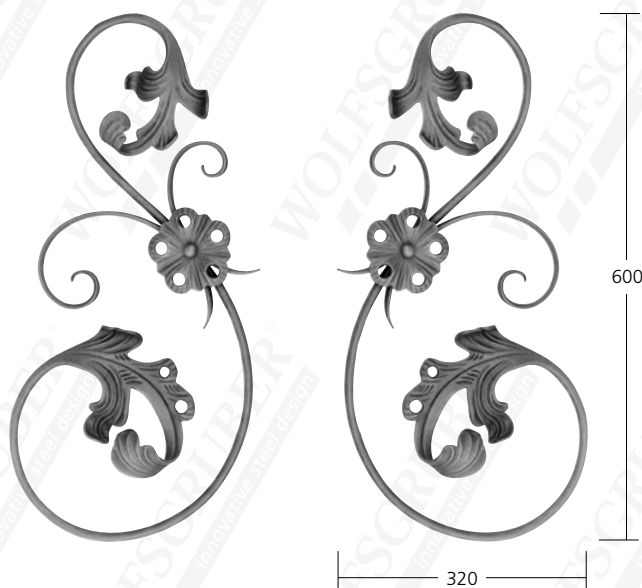

31014 Mat. Ø 12 mm
2,12 kg

31015 Mat. Ø 12 mm
2,12 kg

martellato · gehämmert · hammered

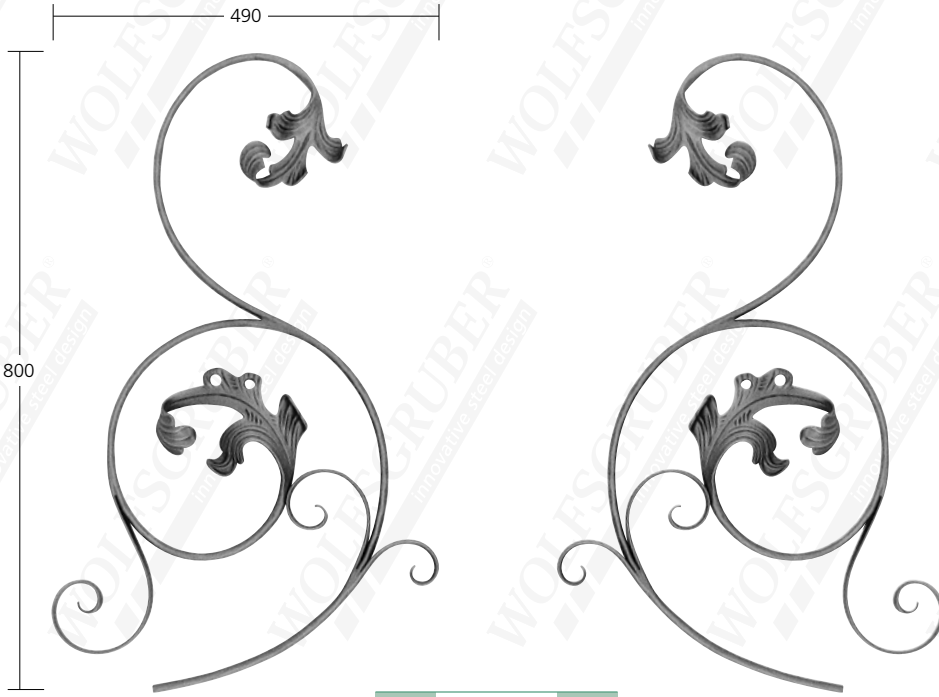

31018 Mat. Ø 12 mm **31019**
2,60 kg

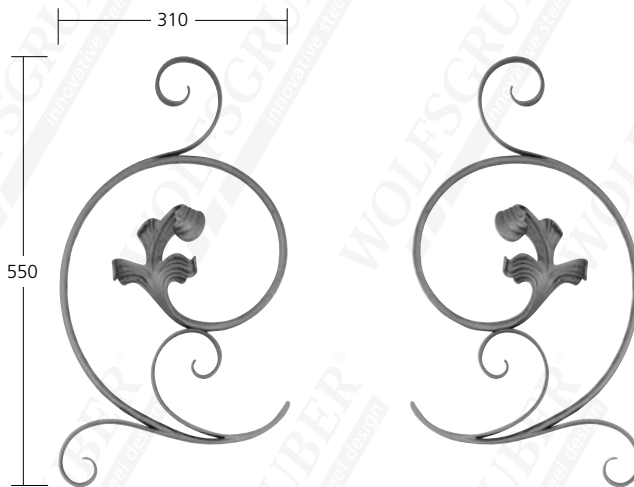

31022 Mat. Ø 12 mm **31023**
1,38 kg

barocco rustico · Ländliches Barock · country baroque

martellato · gehämmert · hammered



31026 Mat. Ø 12 mm **31027**
1,40 kg



31030 Mat. Ø 12 mm **31031**
2,12 kg

martellato · gehämmert · hammered



31034 Mat. Ø 12 mm **31035**
2,60 kg

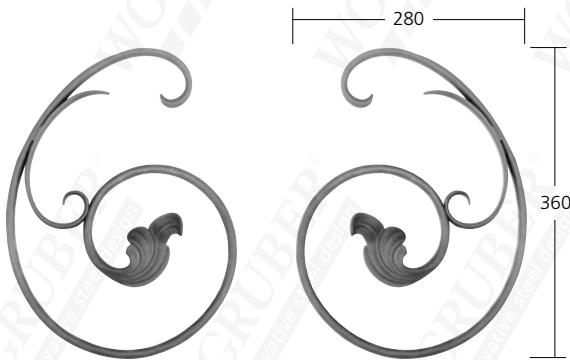

31038 Mat. Ø 12 mm **31039**
1,20 kg

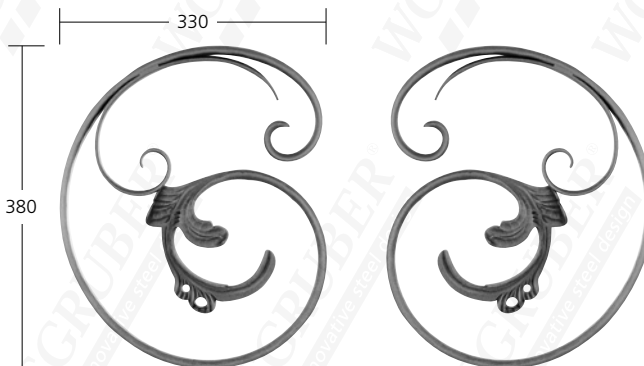

31042 Mat. Ø 12 mm **31043**
1,60 kg



barocco rustico · Ländliches Barock · country baroque

martellato · gehämmert · hammered

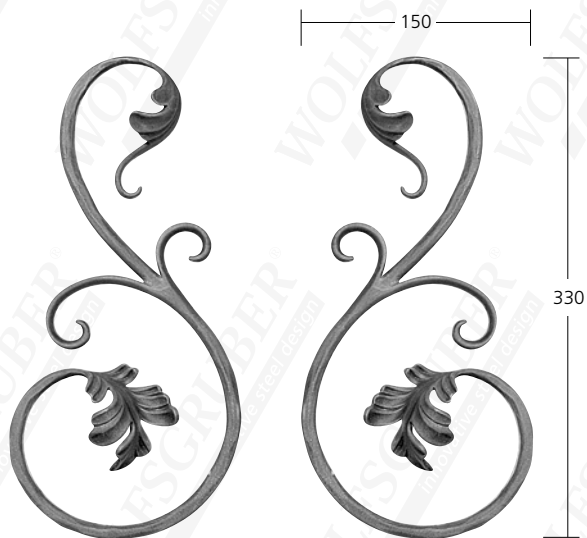

31210 Mat. Ø 10 mm **31211**
0,54 kg

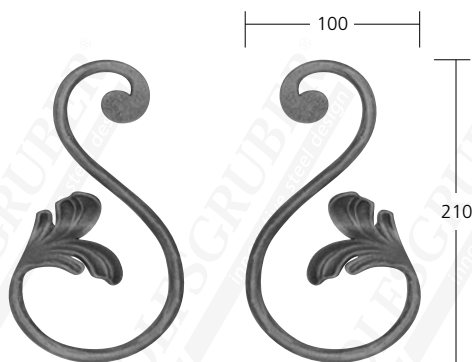

31214 Mat. Ø 10 mm **31215**
0,30kg

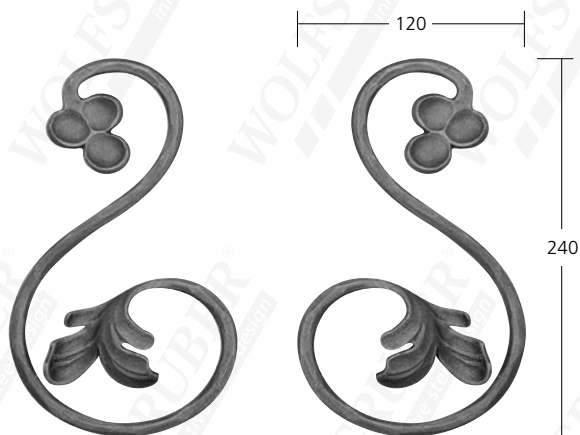

31218 Mat. Ø 10 mm **31219**
0,38 kg

martellato · gehämmert · hammered



31222 Mat. Ø 10 mm **31223**
0,52 kg

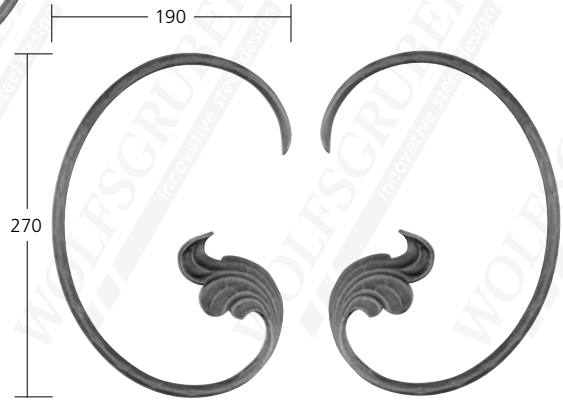

31226 Mat. Ø 10 mm **31227**
0,46 kg

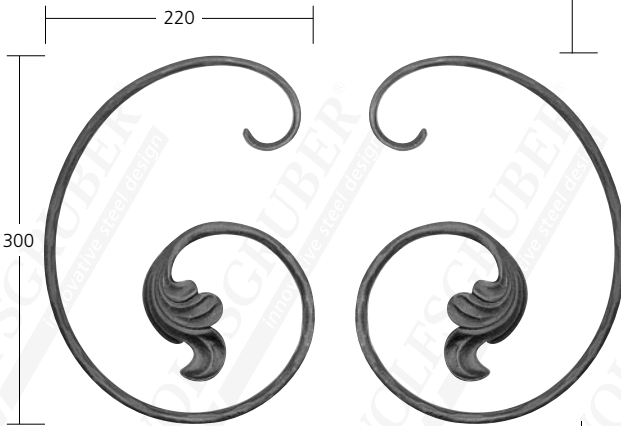

31230 Mat. Ø 10 mm **31231**
0,60 kg

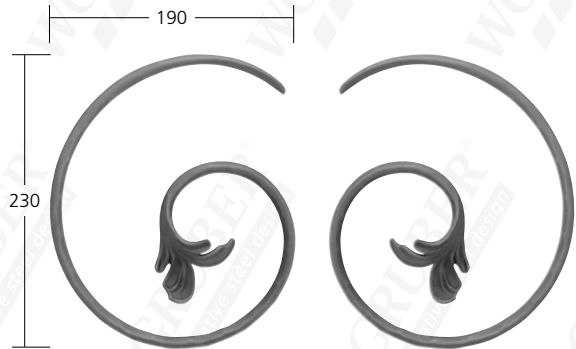

31234 Mat. Ø 10 mm **31235**
0,44 kg

barocco rustico · Ländliches Barock · country baroque

martellato · gehämmert · hammered

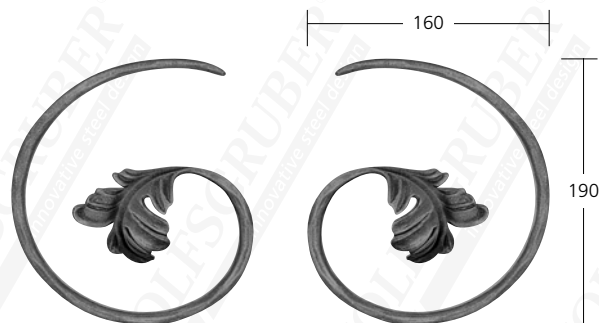

31238 Mat. Ø 10 mm **31239**
0,35 kg

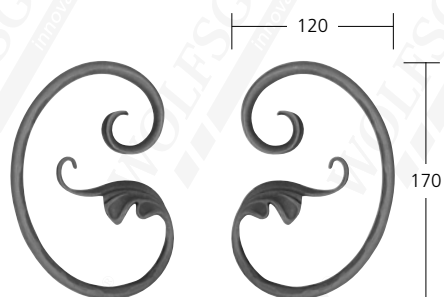

31242 Mat. Ø 10 mm **31243**
0,28 kg

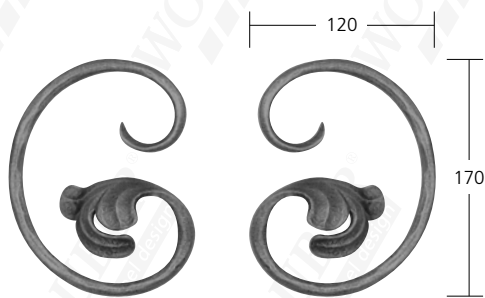

31246 Mat. Ø 10 mm **31247**
0,26 kg

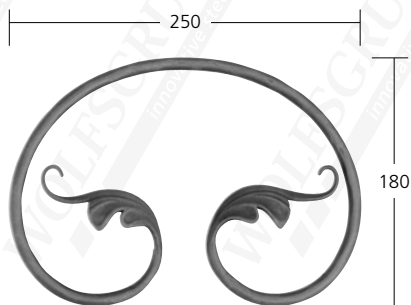

31254 Mat. Ø 10 mm
0,44 kg

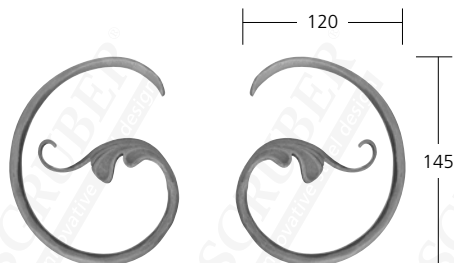

31250 Mat. Ø 10 mm **31251**
0,22 kg

martellato · gehämmert · hammered

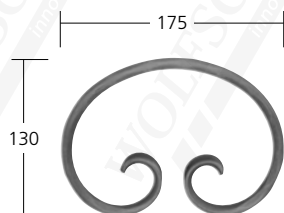

31410 Mat. Ø 10 mm
0,30 kg

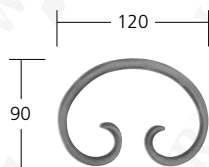

31420 Mat. Ø 10 mm
0,19 kg

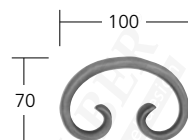

31430 Mat. Ø 10 mm
0,14 kg

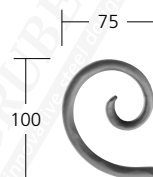

31440 Mat. Ø 10 mm
0,12 kg

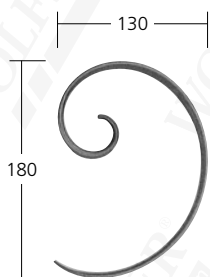

31610 Mat. 15x4 mm
0,16 kg

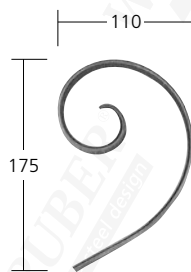

31620 Mat. 15x4 mm
0,17 kg

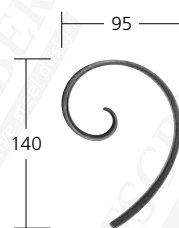

31630 Mat. 15x4 mm
0,12 kg

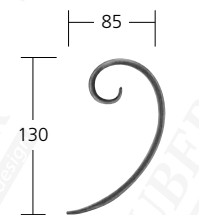

31650 Mat. 15x4 mm
0,10 kg

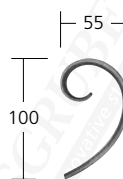

31640 Mat. 15x4 mm
0,06 kg

barocco rustico · Ländliches Barock · country baroque

martellato · gehämmert · hammered

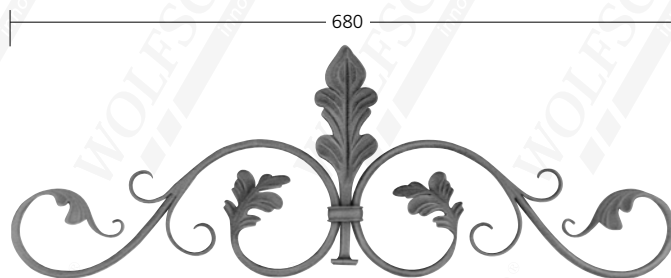

31810 Mat. Ø 10 mm
1,36 kg

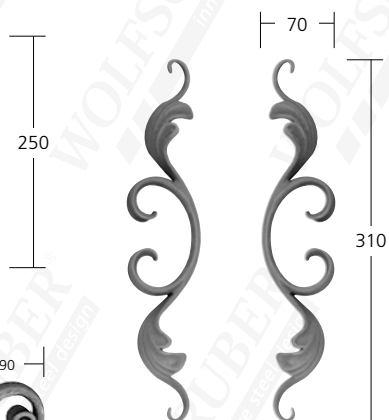

31824 Mat. Ø 10 mm
0,25 kg

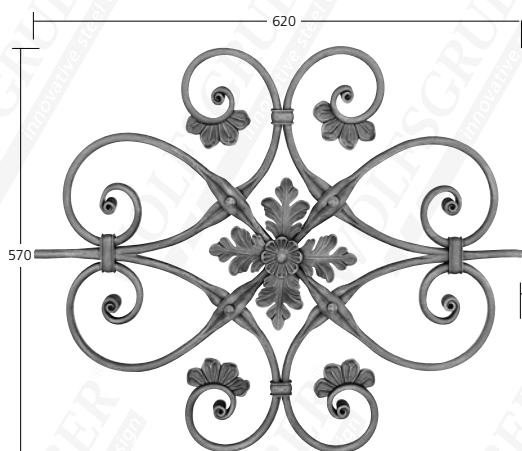

31900 Mat. Ø 14 mm
7,76 kg
liscio · glatt · smooth



31901 Mat. Ø 14 mm
0,50 kg
liscio · glatt · smooth

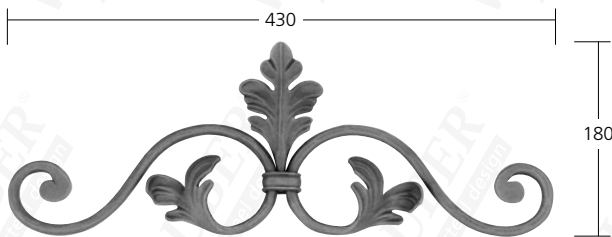

31820 Mat. Ø 10 mm
0,72 kg



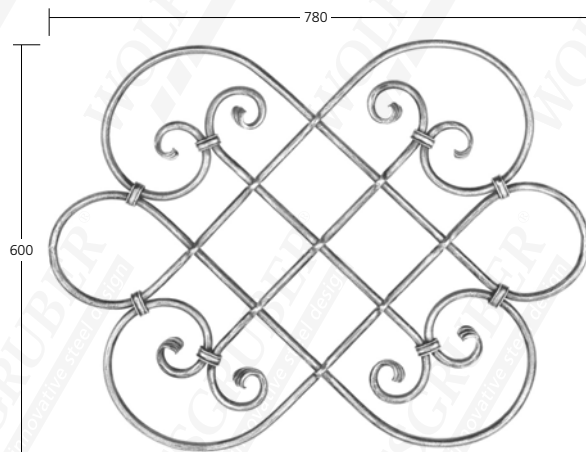

31920 Mat. Ø 12 mm
3,60 kg
liscio · glatt · smooth



81300 7,78 kg

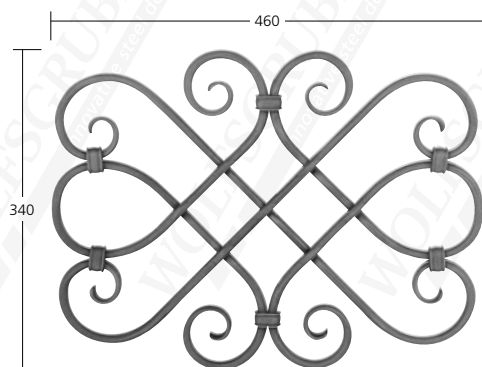

31910 Mat. Ø 10 mm
2,60 kg

martellato · gehämmert · hammered

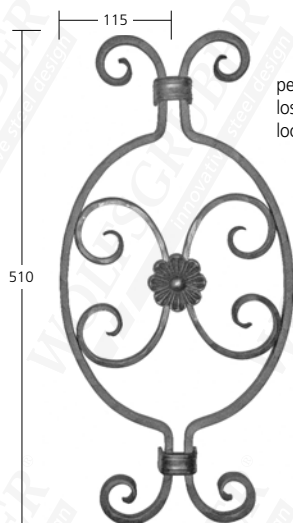

pezzi sciolti
lose
loose

31950 Mat. 14x6-8 mm
2,40 kg

forgiato · geschmiedet · forged



barocco rustico · Ländliches Barock · country baroque

materiale piatto · Flachmaterial · flat material

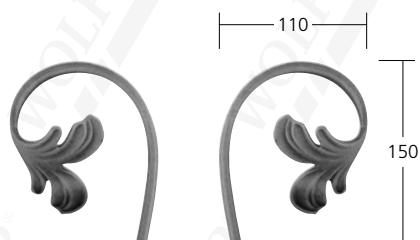

32010 Mat. 12x5 mm **32011**
0,20 kg

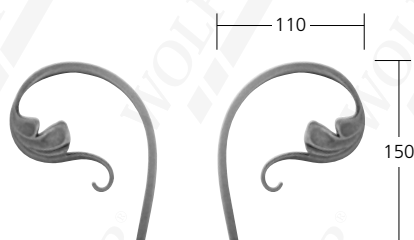

32020 Mat. 12x5 mm **32021**
0,16 kg

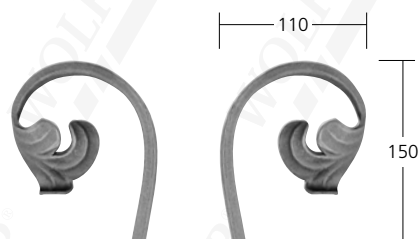

32210 Mat. 16x8 mm **32211**
0,34 kg

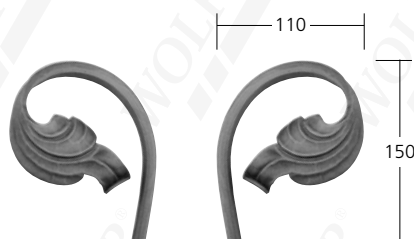

32212 Mat. 16x8 mm **32213**
0,38 kg

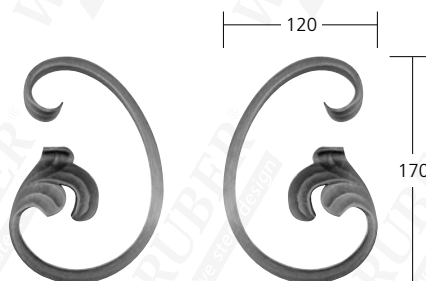

32214 Mat. 16x8 mm **32215**
0,40 kg



32216 Mat. 16x8 mm **32217**
0,54 kg

barocco rustico · Ländliches Barock · country baroque

materiale piatto · Flachmaterial · flat material

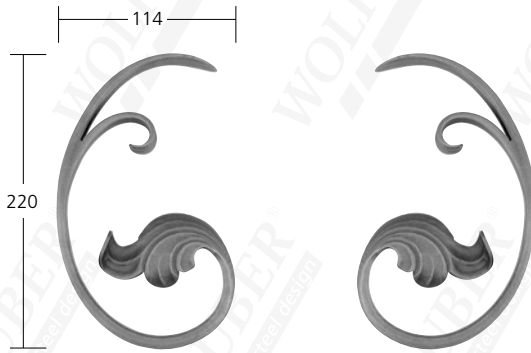

32230 Mat. 16x8 mm **32231**
0,60 kg



32234 Mat. 16x8 mm **32235**
1,50 kg

barocco rustico · Ländliches Barock · country baroque

materiale piatto · Flachmaterial · flat material

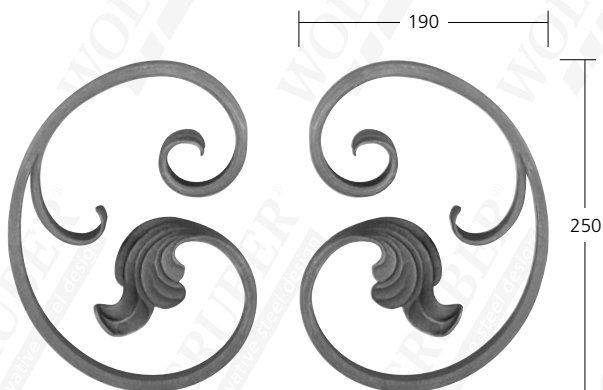

32238 Mat. 16x8 mm **32239**
0,92 kg

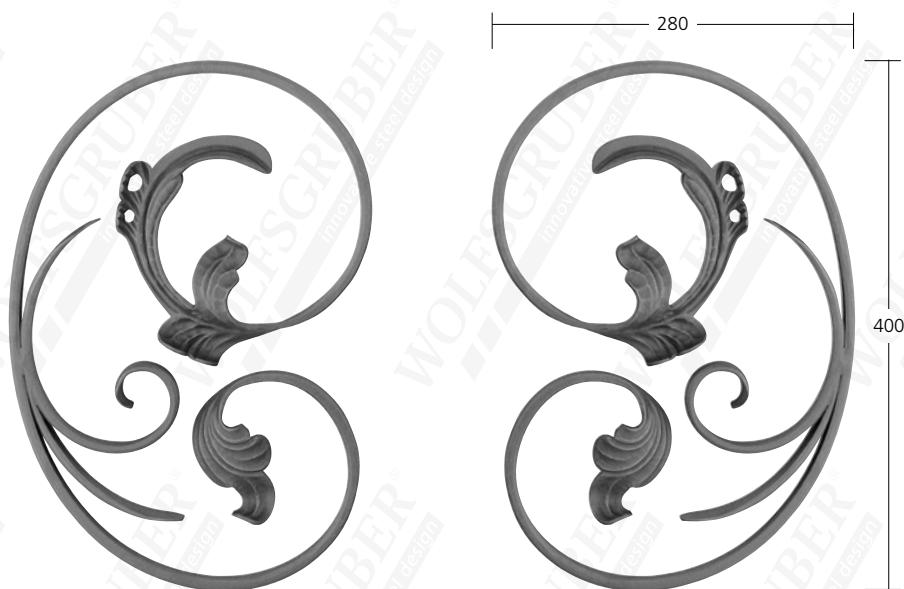

32250 Mat. 16x8 mm **32251**
1,84 kg

materiale piatto · Flachmaterial · flat material

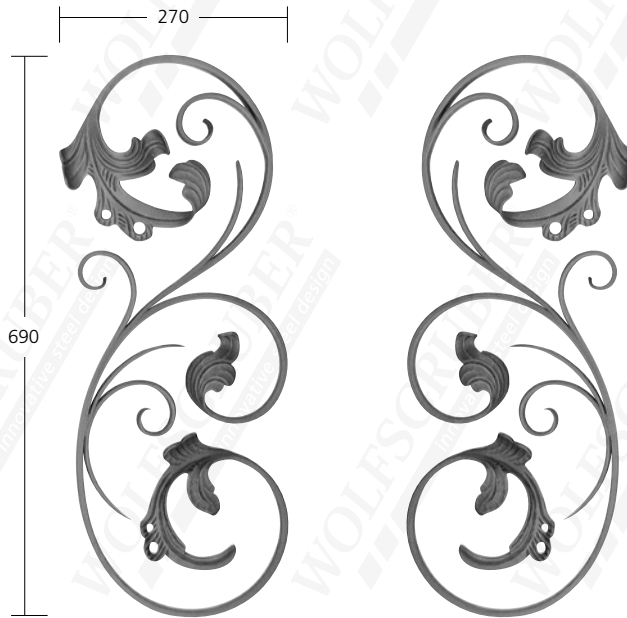

32254 Mat. 16x8 mm **32255**
3,35 kg

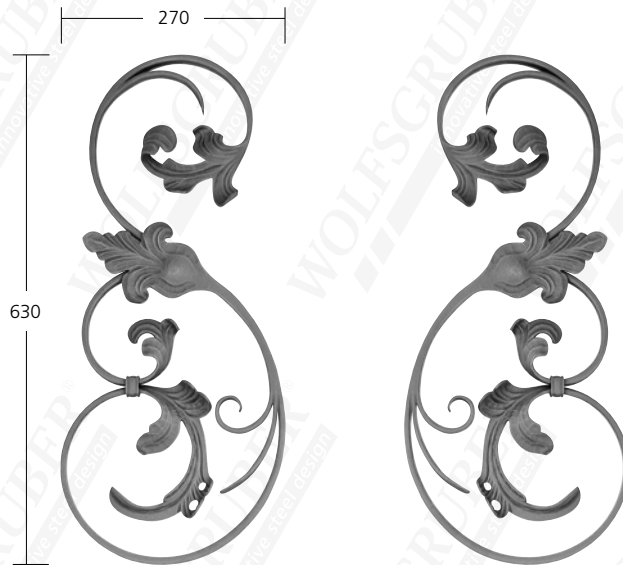

32258 Mat. 16x8 mm **32259**
2,86 kg



materiale piatto · Flachmaterial · flat material

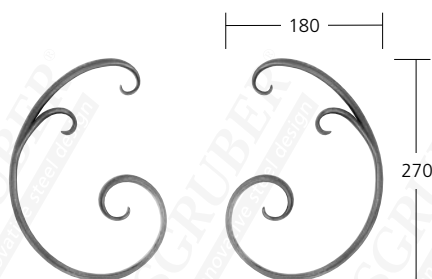

32410 Mat. 16x8 mm
0,78 kg

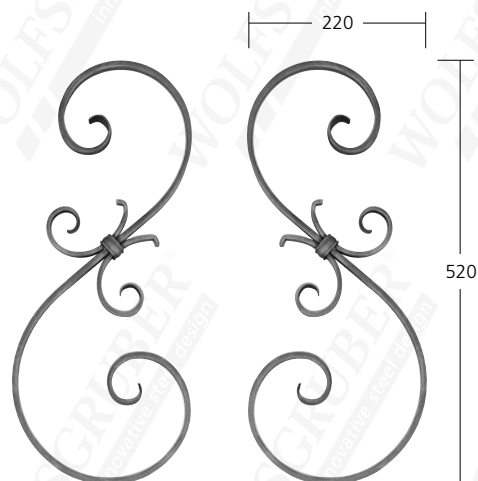

32414 Mat. 16x8 mm **32415**
1,66 kg

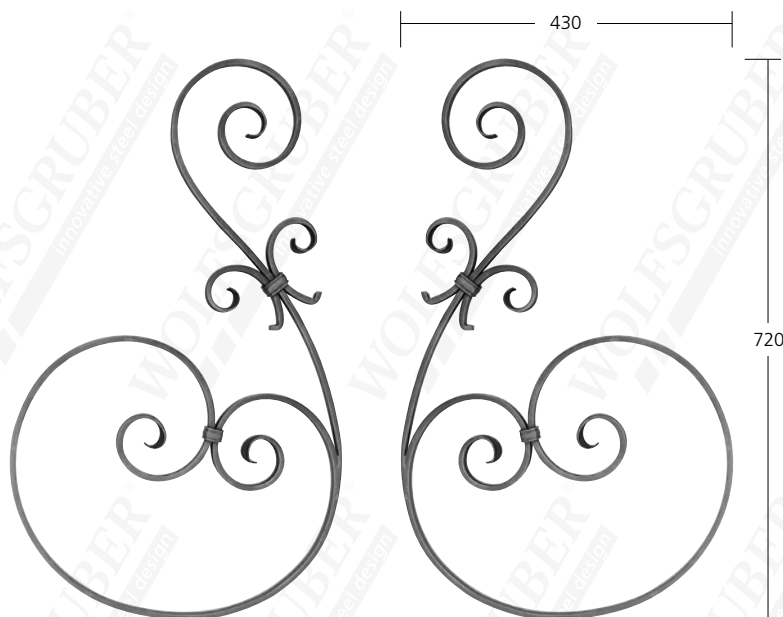

32418 Mat. 16x8 mm **32419**
3,40 kg

materiale piatto · Flachmaterial · flat material

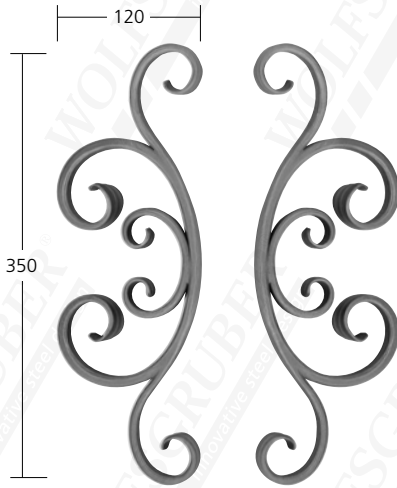

32430 Mat. 16x8 mm
0,95 kg

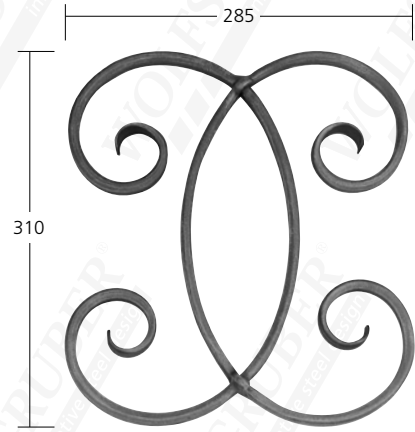

32424 Mat. 16x8 mm
1,86 kg

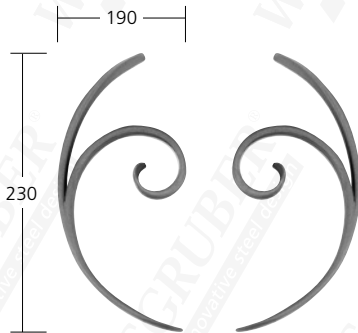

32434 Mat. 16x6 mm
0,38 kg

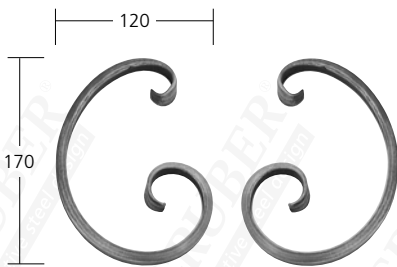

32438 Mat. 16x8 mm
0,46 kg



materiale piatto · Flachmaterial · flat material

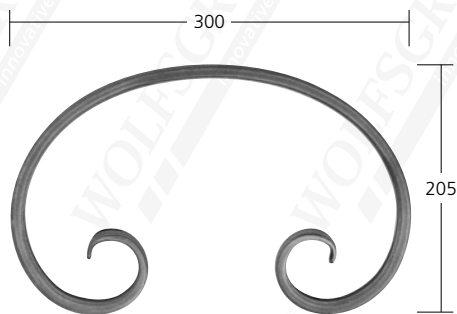

32450 Mat. 16x8 mm
1,00 kg

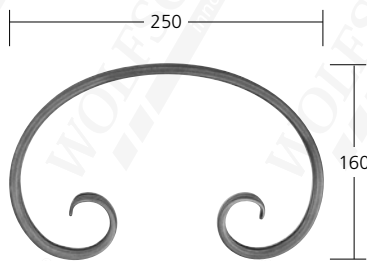

32452 Mat. 16x8 mm
0,68 kg

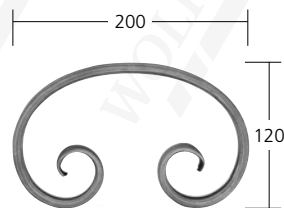

32454 Mat. 16x8 mm
0,60 kg

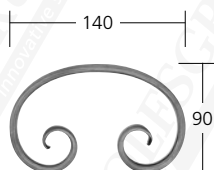

32456 Mat. 16x8 mm
0,38 kg

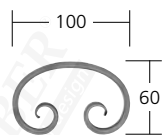

32458 Mat. 16x6 mm
0,16 kg

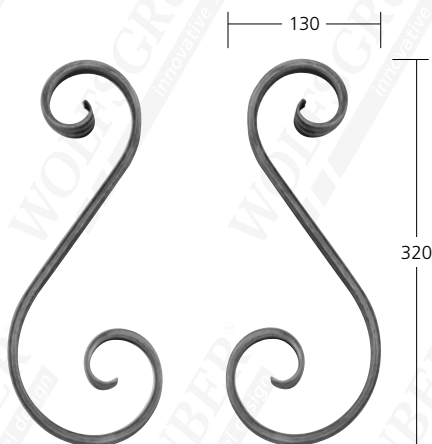

32460 Mat. 16x8 mm
0,58 kg

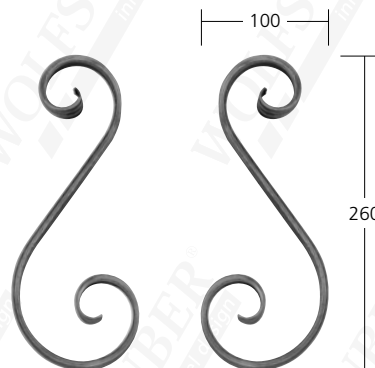

32462 Mat. 16x8 mm
0,70 kg



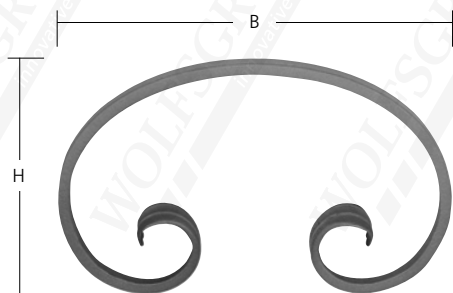

	B	H	Mat.
34014	80	50	12x5
34012	100	60	12x5
34010	120	70	12x5
34015	130	80	12x5
34018	150	80	12x5
34017	180	100	12x5
34016	220	130	12x5

	B	H	Mat.
35014	80	50	12x6
35012	100	60	12x6
35010	120	70	12x6
35015	130	80	12x6
35018	150	80	12x6
35017	180	100	12x6
35016	220	130	12x6

	B	H	Mat.
34110	60	150	12x5
34120	70	170	12x5
34130	120	240	12x5

	B	H	Mat.
35110	60	150	12x6
35120	70	170	12x6
35130	120	240	12x6

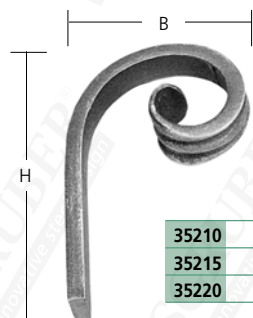
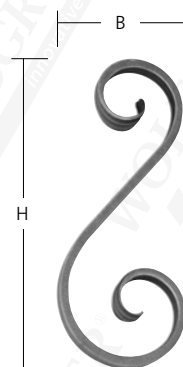

	B	H	Mat.
35210	50	100	12x6
35215	60	100	12x6
35220	70	100	12x6

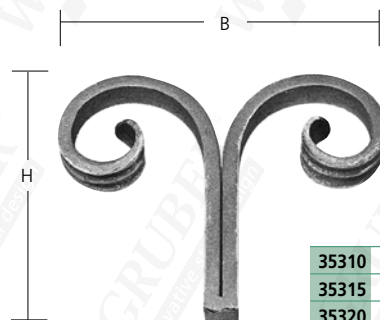

	B	H	Mat.
35310	100	100	12x6
35315	120	100	12x6
35320	140	100	12x6

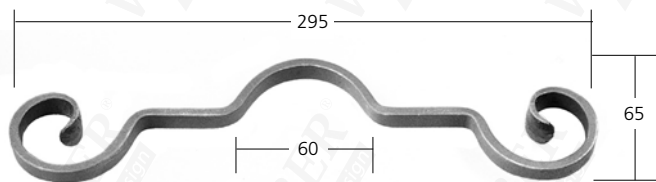

35410	Mat. 12x6 mm
0,22 kg	

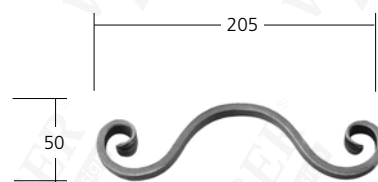

35420	Mat. 12x6 mm
0,18 kg	

barocco antico · Schwerbarock · antique baroque

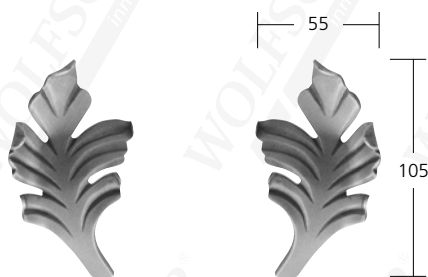

36010 Mat. 3 mm **36011**
0,08 kg



36012 Mat. 3 mm
0,08 kg

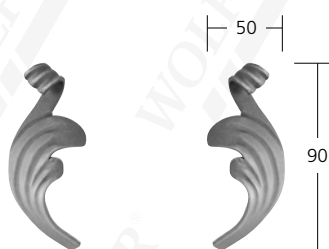

36014 Mat. 3 mm **36015**
0,06 kg

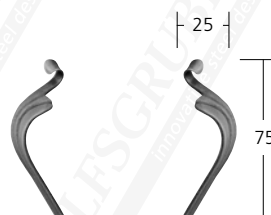

36016 Mat. 2,5 mm **36017**
0,04 kg

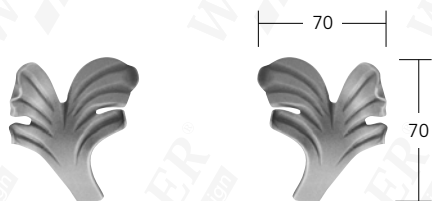

36018 Mat. 3 mm **36019**
0,06 kg

barocco leggero · Leichtbarock · light baroque

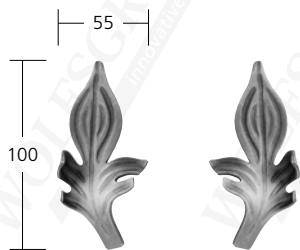

36050 Mat. 2,5 mm **36051**
0,06 kg

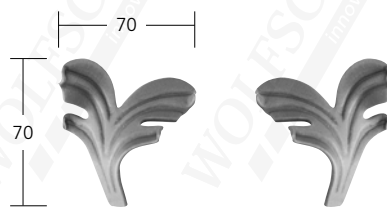

36054 Mat. 2,5 mm **36055**
0,05 kg

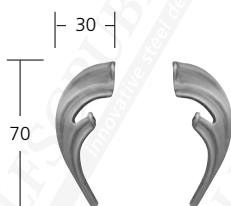

36056 Mat. 2,5 mm **36057**
0,03 kg

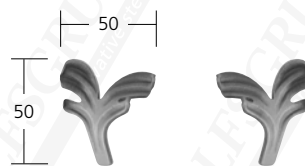

36058 Mat. 2,5 mm **36059**
0,03 kg

Creste barocche · Barockkämme · Baroque combs

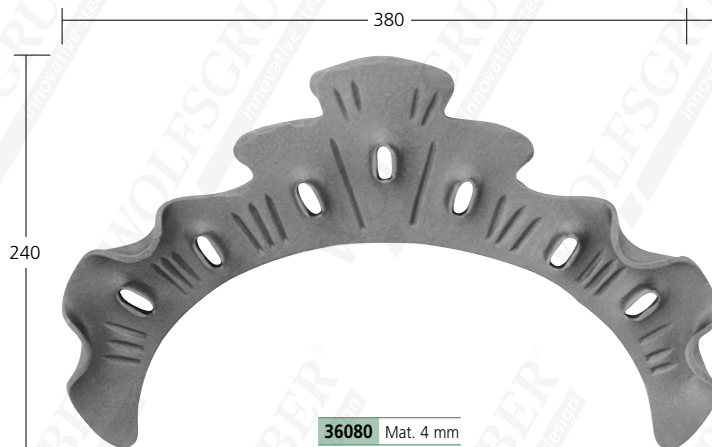

36080 Mat. 4 mm
1,08 kg

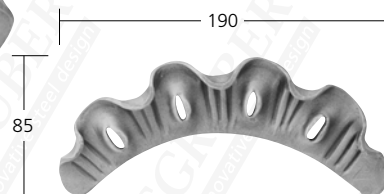

36082 Mat. 4 mm
0,28 kg

barocco leggero · Leichtbarock · light baroque



36110 Mat. 10x3 mm
0,04 kg



36111 Mat. 10x3 mm
0,04 kg



36112 Mat. 12x5 mm
0,11 kg

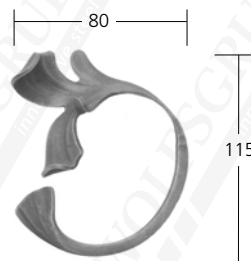

36113 Mat. 12x5 mm
0,11 kg



36114 Mat. 12x5 mm
0,15 kg



36115 Mat. 12x5 mm
0,15 kg



36120 Mat. 12x5 mm
0,70 kg

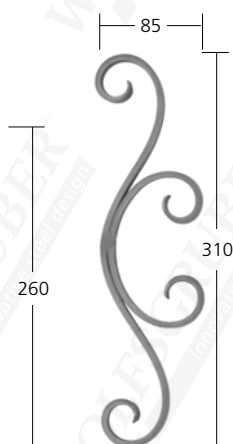

36121 Mat. 12x5 mm

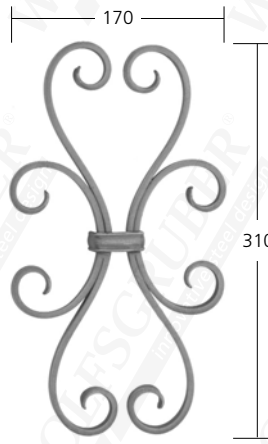

36122 Mat. 12x5 mm
0,80 kg

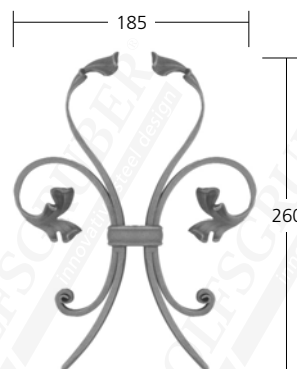

36124 Mat. 12x5 mm
0,62 kg

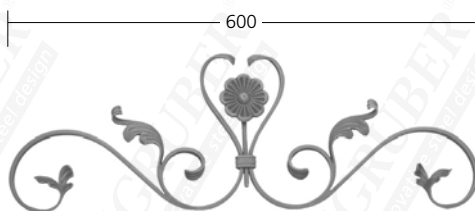

36126 Mat. 12x5 mm
1,10 kg

barocco leggero · Leichtbarock · light baroque

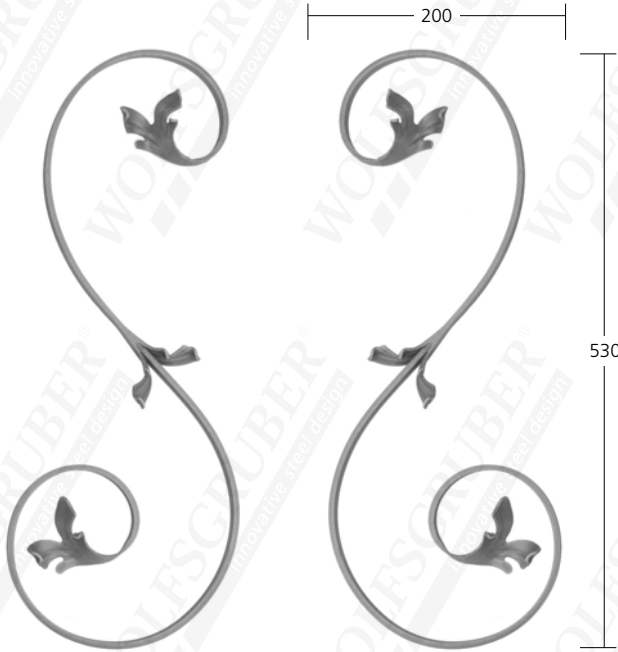

36130 Mat. 12x5 mm
0,72 kg

36131 Mat. 12x5 mm
0,72 kg

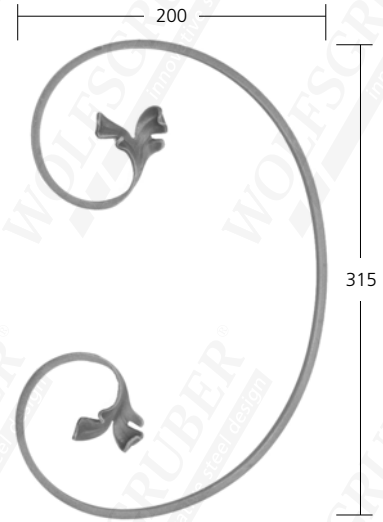

36134 Mat. 12x5 mm
0,46 kg

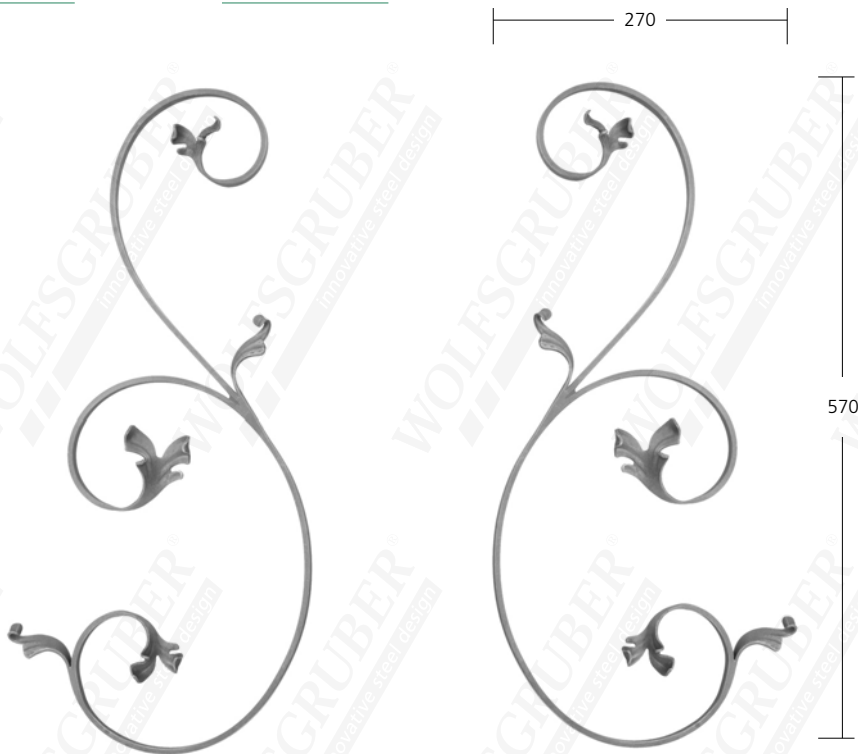

36136 Mat. 12x5 mm
0,74 kg

36137 Mat. 12x5 mm
0,74 kg

barocco leggero · Leichtbarock · light baroque



36140 Mat. 12x5 mm
0,17 kg

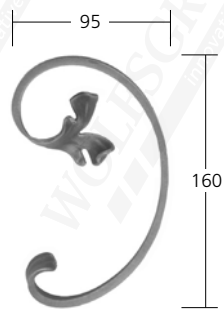

36141 Mat. 12x5 mm
0,17 kg



36142 Mat. 12x5 mm
0,20kg



36143 Mat. 12x5 mm
0,20 kg

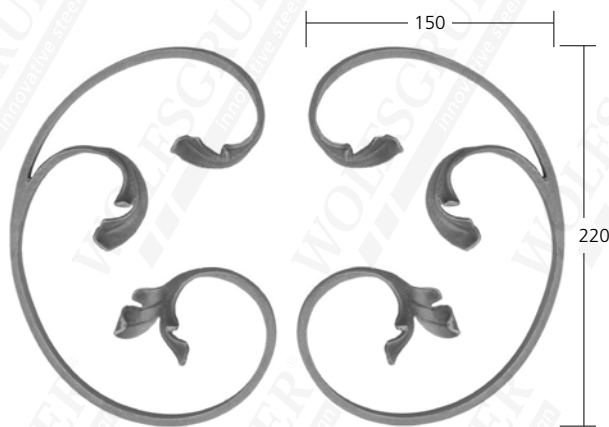

36146 Mat. 12x5 mm
0,32 kg



36147 Mat. 12x5 mm
0,32 kg

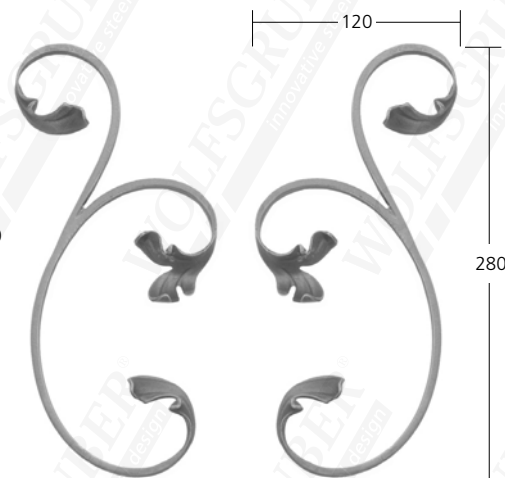

36148 Mat. 12x5 mm
0,30 kg

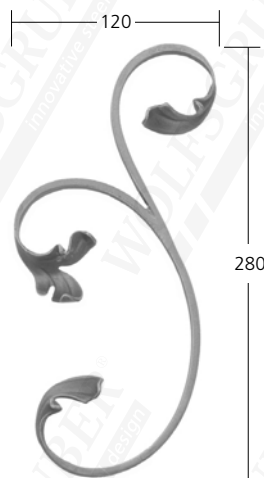

36149 Mat. 12x5 mm
0,30 kg

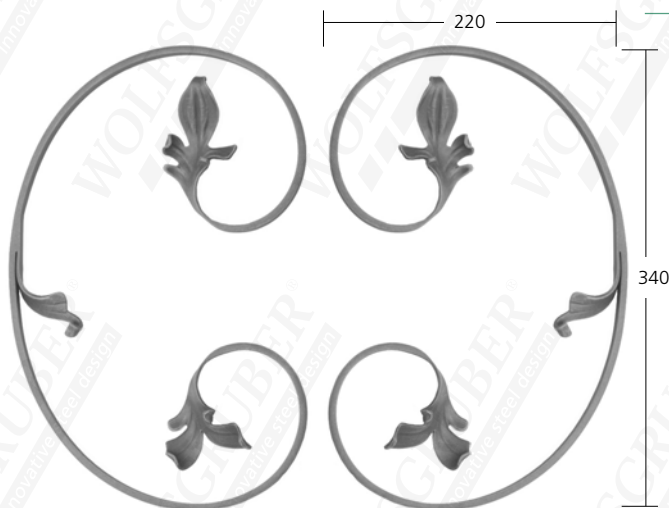

36150 Mat. 12x5 mm
0,54 kg

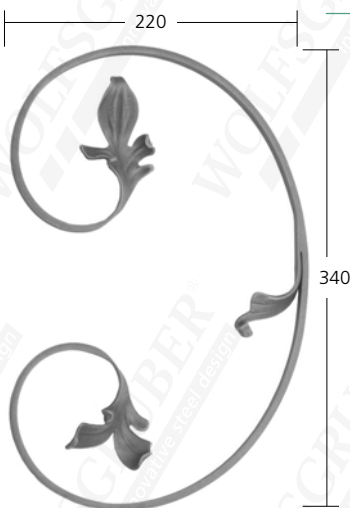

36151 Mat. 12x5 mm
0,54 kg

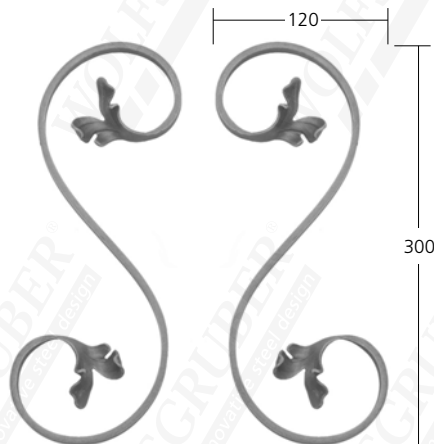

36152 Mat. 12x5 mm
0,31 kg



36153 Mat. 12x5 mm
0,31 kg

barocco antico · Schwerbarock · antique baroque

scanalato · gerillt · grooved

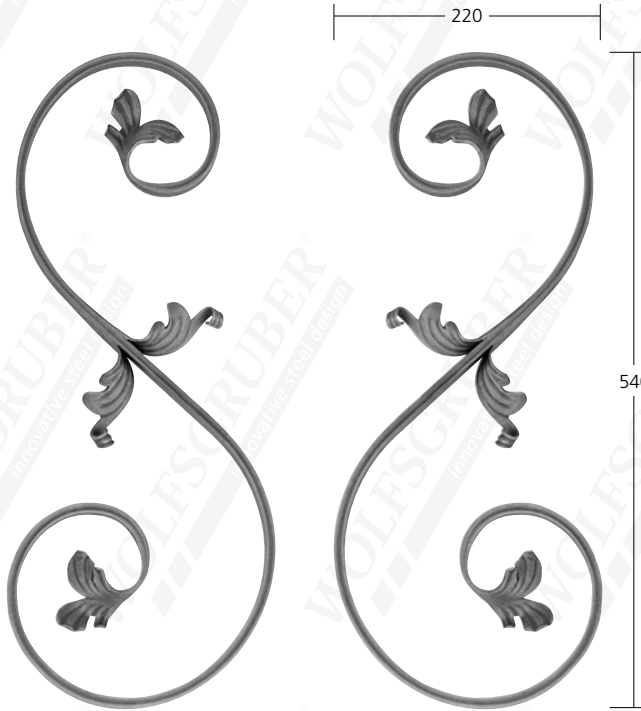

36210 Mat. 16X8 mm **36211**
1,40 kg

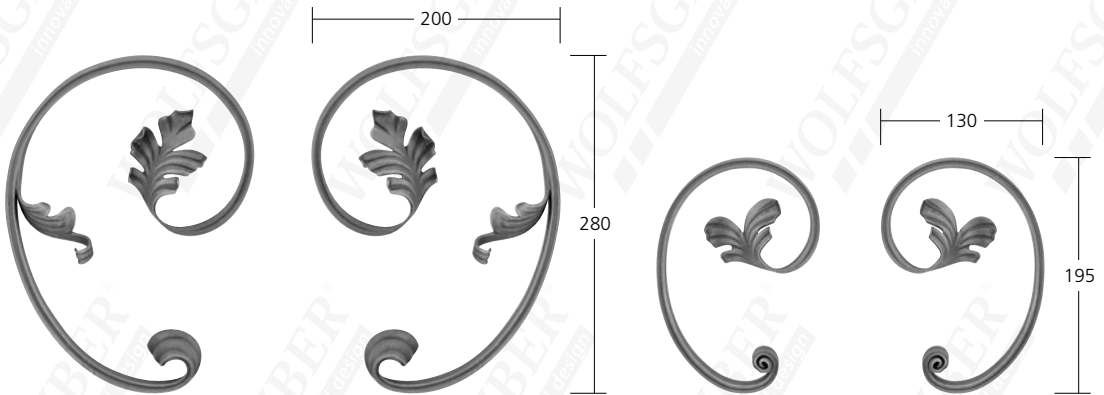

36220 Mat. 16X8 mm **36221**
0,80 kg

36230 Mat. 16X8 mm **36231**
0,50 kg

barocco antico · Schwerbarock · antique baroque

scanalato · gerillt · grooved

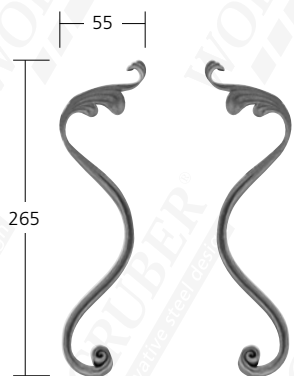

36240 Mat. 16x8 mm **36241**
0,30 kg

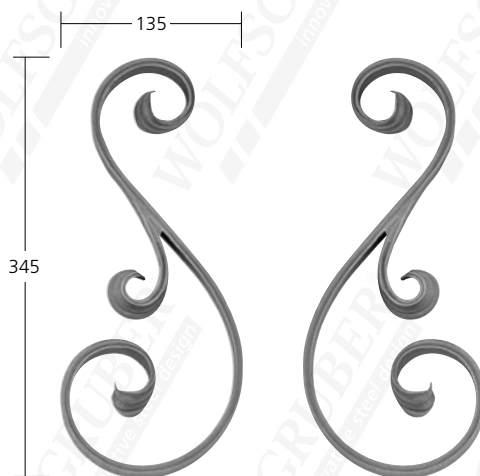

36410 Mat. 16x8 mm **36411**
0,90 kg

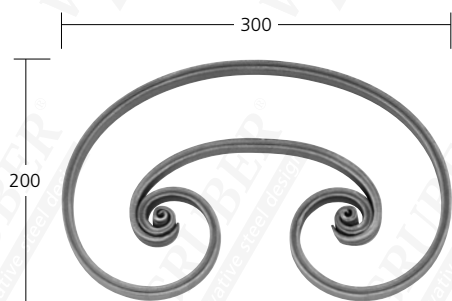

36420 Mat. 16x8 mm
1,30 kg

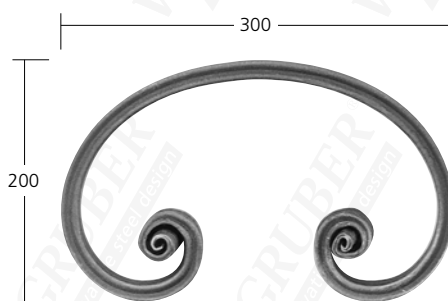

36422 Mat. 16x8 mm
1,00 kg

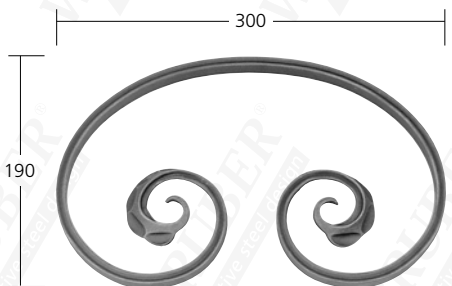

36430 Mat. 16x8 mm
1,00 kg

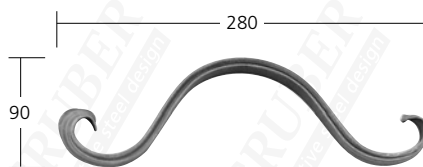

36440 Mat. 16x8 mm
0,40 kg

scanalato · gerillt · grooved

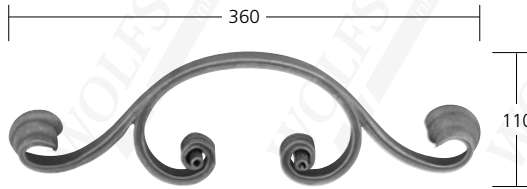

36450 Mat. 16x8 mm
0,80 kg



36452 Mat. 16x8 mm
0,50 kg

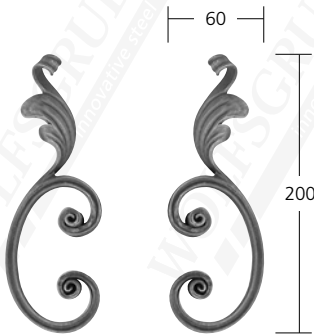

36460 Mat. 16X8 mm **36461**
0,35 kg

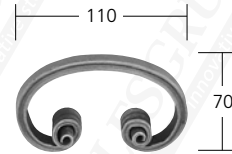

36462 Mat. 16x8 mm
0,34 kg



36510 Mat. 16X8 mm **36511**
0,28 kg



36514 Mat. 16X8 mm **36515**
0,25 kg



36530 Mat. 16x8 mm
0,30 kg

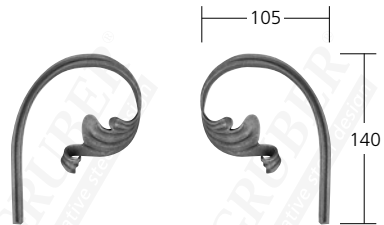

36518 Mat. 16X8 mm **36519**
0,25 kg

barocco antico · Schwerbarock · antique baroque

scanalato · gerillt · grooved

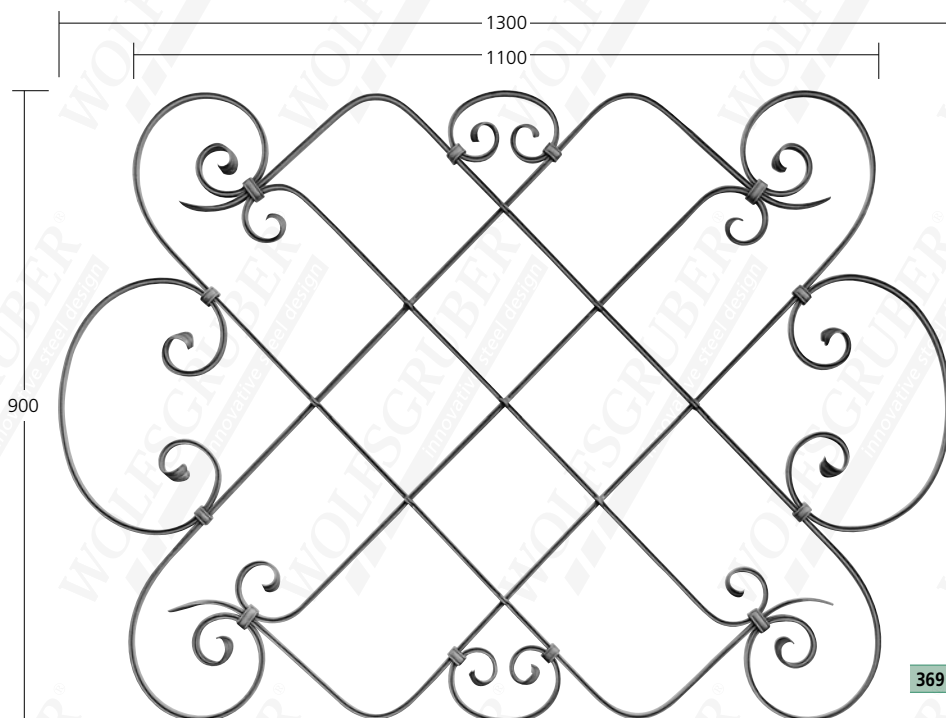

36910 Mat. 16x8 mm
13,20 kg

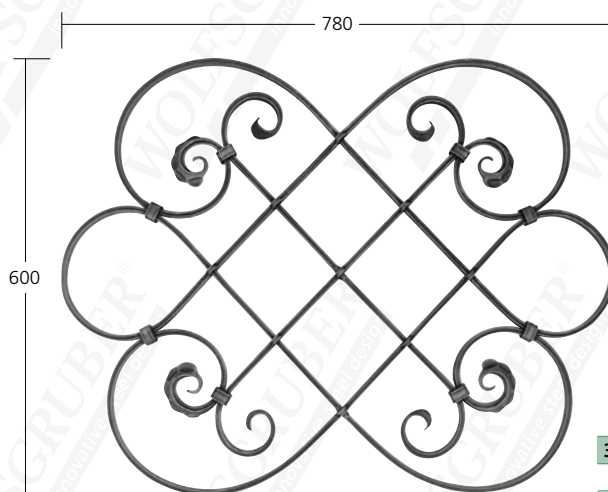

36920 Mat. 16x8 mm
7,40 kg

scanalato · gerillt · grooved

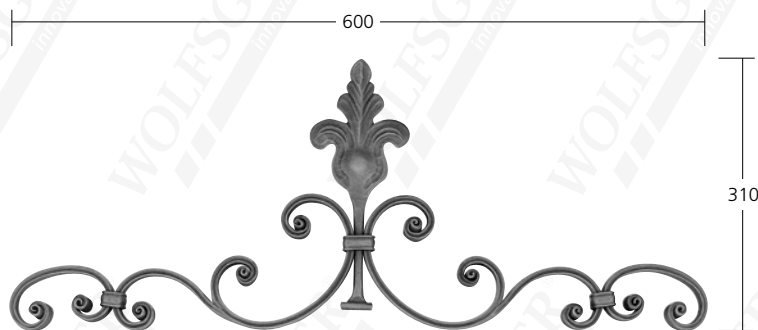

36960 Mat. 16x8 mm
2,27 kg

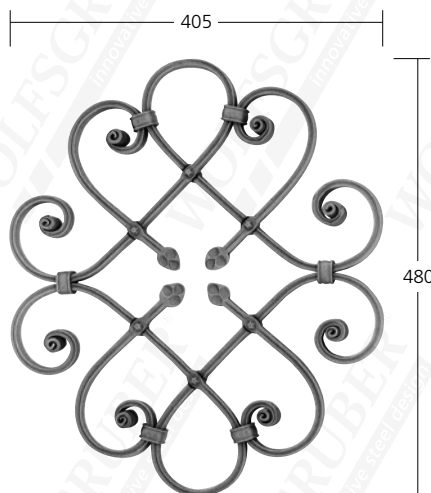

36930 Mat. 16x8 mm
4,00 kg

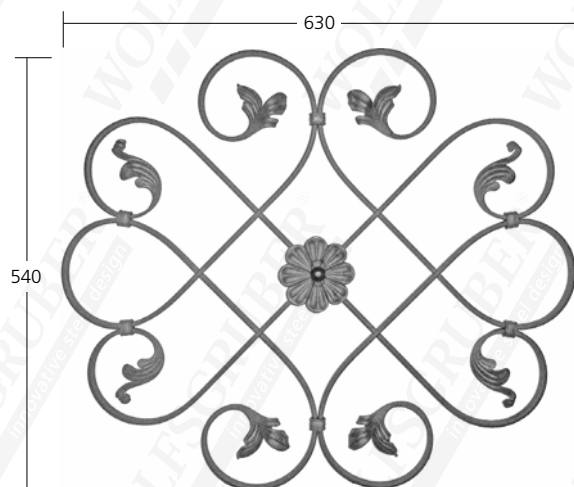

36940 Mat. 12x6 mm
2,9 kg

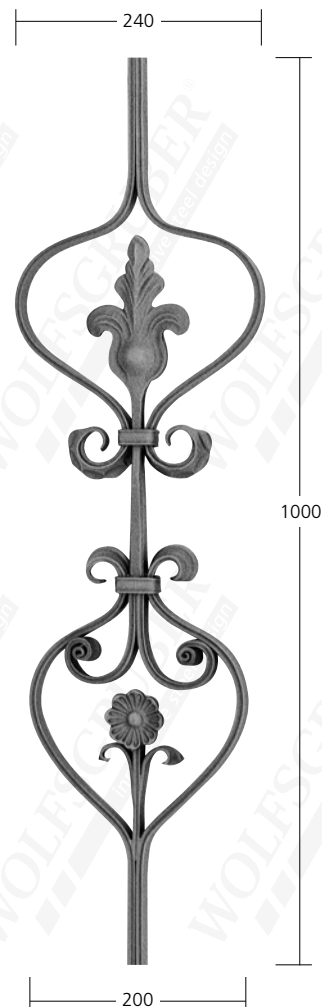

36980 Mat. 16x8 mm
3,60 kg

Serie
Trenta

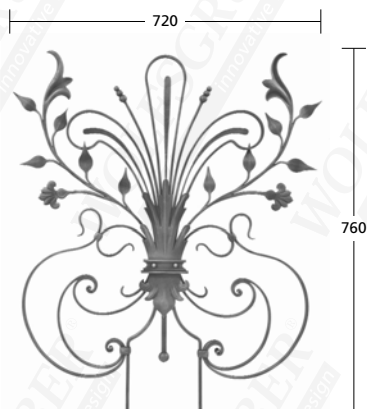

37020 15x8 / 12x6 mm

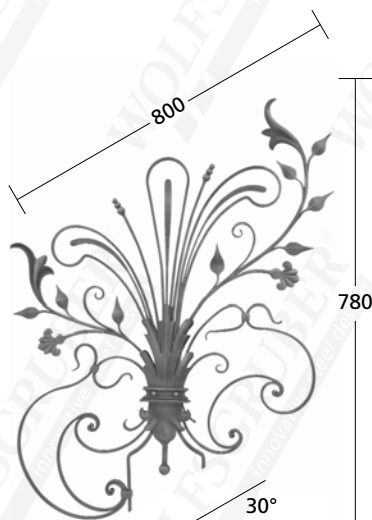

37022 15x8 / 12x6 mm

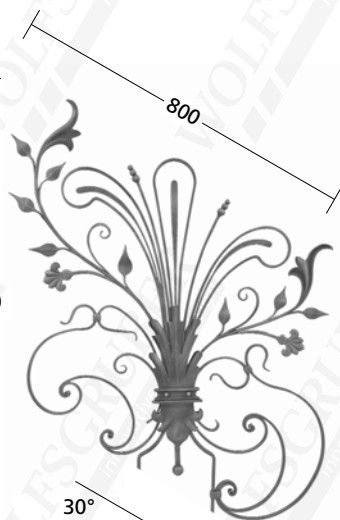

37023 15x8 / 12x6 mm

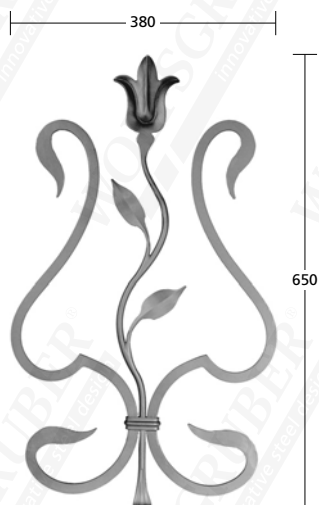

37110

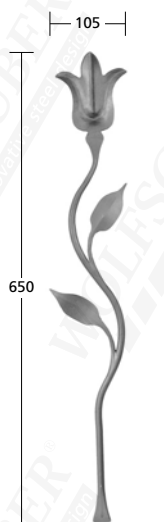

37114 ø 10 mm



37115 12x6 mm



37116 12x6 mm



Cena
Trenta



37130 12x6 mm

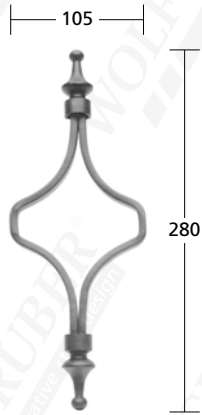

37132 12x6 mm



37140



37142

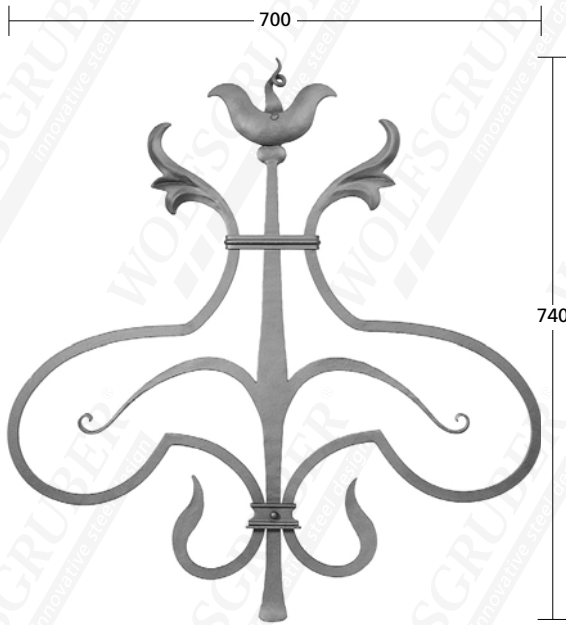

37120



12 x 12 x 6 fascetta - Bund

37152 16x3 mm

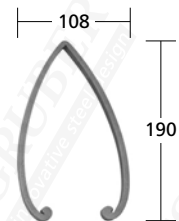

37150 12x6 mm



37125 12x6 mm

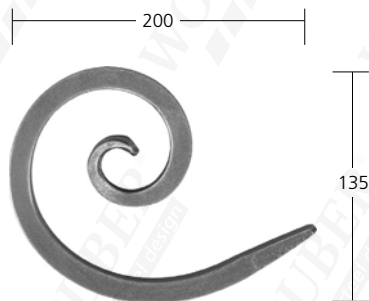

35710 Mat. 14x14

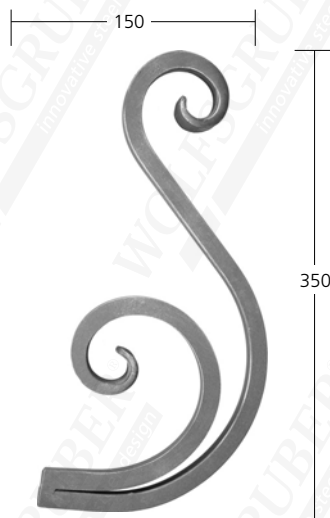

35720 Mat. 14x14

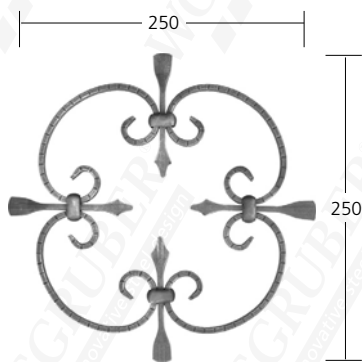

35820 Mat. 10x5

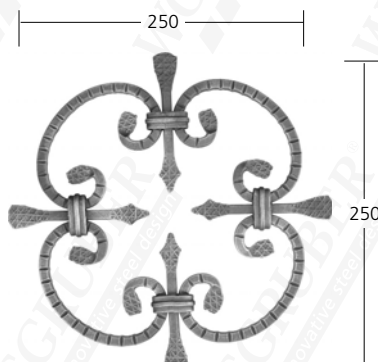

35810 Mat. 8x8

OGGETTI PICCOLI
KLEINTEILE
SMALL OBJECTS



WOLFSGRUBER



innovative steel design

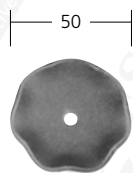

40010 Mat. 2 mm
0,03 kg
foro
Loch · hole Ø 5,5 mm



40020 Mat. 1 mm
0,02 kg
foro
Loch · hole Ø 5,5 mm



40030 Mat. 1 mm
0,01 kg
foro
Loch · hole Ø 5,5 mm



48500 Mat. Ø 5 mm
0,01 kg

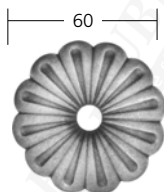

40060 Mat. 3 mm



40065 Mat. 10 mm

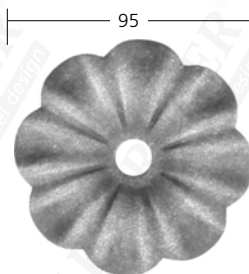

40090 Mat. 3 mm

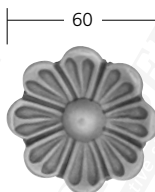

40106 Mat. 5 mm
0,10 kg

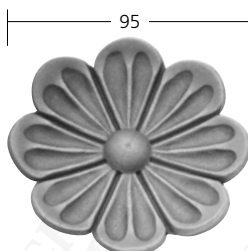

40110 Mat. 4 mm
0,20 kg

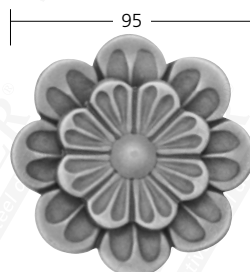

40116 Mat. 4 mm
0,20 kg



40120 Mat. 4 mm
0,20 kg

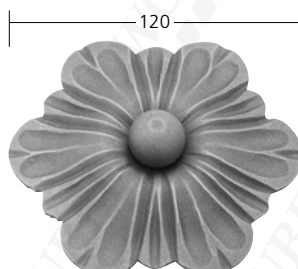

40125 Mat. 4 mm
0,32 kg

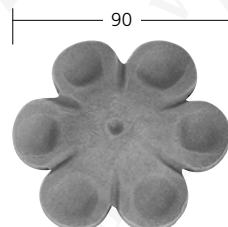

40130 Mat. 5 mm
0,24 kg



40135 Mat. 4 mm
0,24 kg

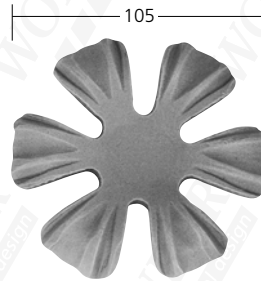

40140 Mat. 6 mm
0,26 kg

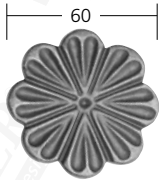

40206 Mat. 5 mm
0,08 kg

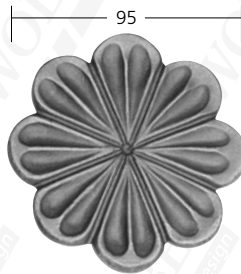

40210 Mat. 4 mm
0,18 kg

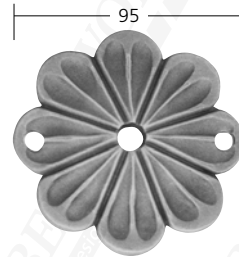

40220 Mat. 4 mm
0,17 kg
foro
Loch · hole Ø 10,5-7 mm

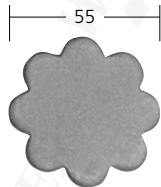

40306 Mat. 5 mm
0,08 kg

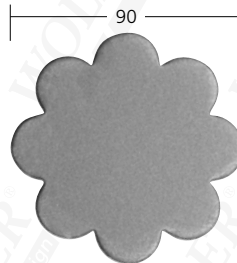

40310 Mat. 4 mm
0,18 kg

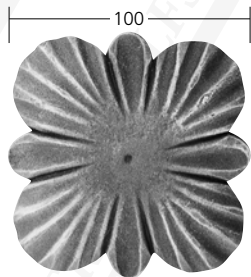

40610 Mat. 6 mm
0,36 kg

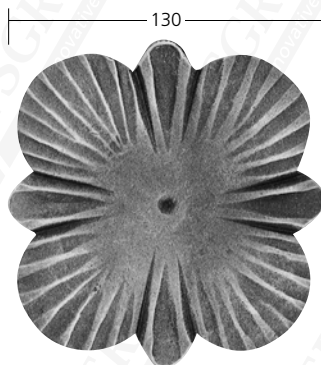

40620 Mat. 6 mm
0,62 kg

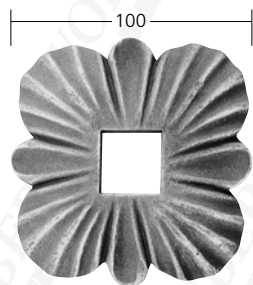

40618 Mat. 6 mm
0,32 kg
∅25,5 mm

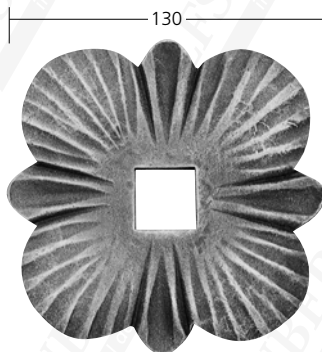

40628 Mat. 6 mm
0,58 kg
∅25,5 mm

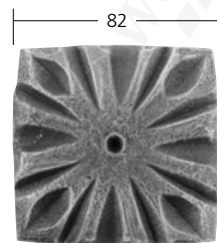

40630 Mat. 8 mm
0,40 kg

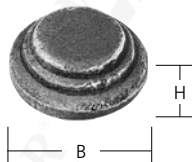

	B	H	
40604	40	15	0,075 kg
40605	50	15	0,125 kg
40606	60	18	0,220 kg
40608	80	18	0,330 kg

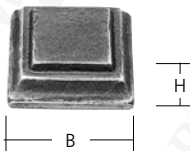

	B	H	
40634	40	15	0,075 kg
40635	50	15	0,125 kg
40636	60	18	0,220 kg
40638	80	18	0,330 kg

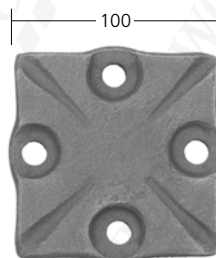

40632 Mat. 8 mm
0,40 kg

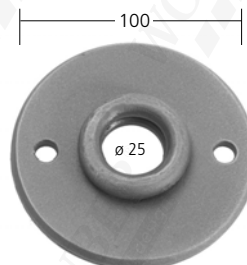

40622 Mat. 6 mm
0,34 kg

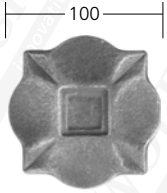

40670 Mat. 10 mm

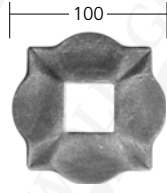

40672 Mat. 10 mm

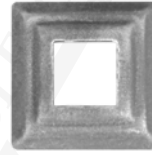

H = 20 mm

40682	Mat. 40x40 - \varnothing 12,5 mm
40684	Mat. 50x50 - \varnothing 20,5 mm
40685	Mat. 60x60 - \varnothing 25,5 mm
40686	Mat. 60x60 - \varnothing 30,5 mm
40687	Mat. 80x80 - \varnothing 30,5 mm
40688	Mat. 80x80 - \varnothing 40,5 mm

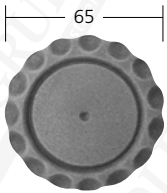

40640 Mat. 5 mm
0,12 kg

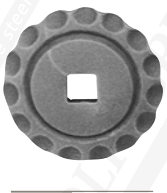

40642 Mat. 5 mm
0,11 kg
 \varnothing 12,5 mm



40645 Mat. 5 mm
0,10 kg



40647 Mat. 5 mm
0,09 kg
 \varnothing 12,5 mm

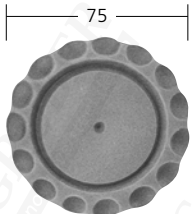

40650 Mat. 5 mm
0,15 kg

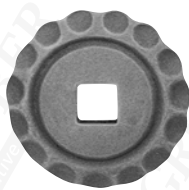

40654 Mat. 5 mm
0,14 kg
 \varnothing 16,5 mm

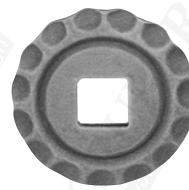

40656 Mat. 5 mm
0,13 kg
 \varnothing 20,5 mm



40658 Mat. 5 mm
0,12 kg
 \varnothing 25,5 mm



40660 Mat. 5 mm
0,16 kg



40664 Mat. 5 mm
0,15 kg
 \varnothing 16,5 mm



40666 Mat. 5 mm
0,14 kg
 \varnothing 20,5 mm



40668 Mat. 5 mm
0,13 kg
 \varnothing 25,5 mm



41012 0,95 kg



41014 1,85 kg



41016 3,70 kg



41018 5,50 kg



41024 0,80 kg



41028 6,40 kg



41032 0,60 kg



41034 1,70 kg



41038 5,30 kg



41042 0,50 kg



41044 0,90 kg



41048 5,50 kg



	Mat.	B	H
41301	Ø12	44	98
41302	Ø15	55	122



41314N Ø 20 mm
0,25 kg



41316N Ø 32 mm
0,65 kg

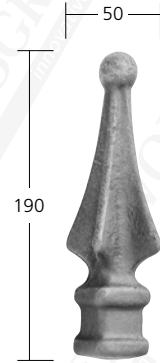

41318N Ø 41 mm
1,13 kg

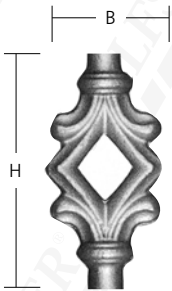

	Mat.	B	H
41320	Ø12	45	95
41321	Ø15	56	120

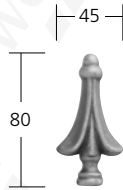

41322N Ø 19 mm
0,15 kg

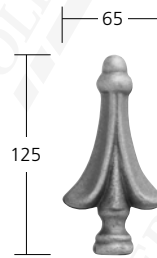

41324N Ø 24 mm
0,35 kg



41326 Ø 36 mm
0,85 kg

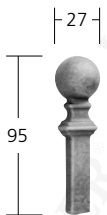

41332 Ø 12 mm
0,16 kg



41334 Ø 18 mm
0,40 kg

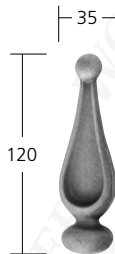

41344 Ø 30 mm
0,25 kg

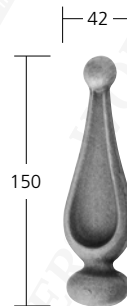

41346 Ø 33 mm
0,38 kg



41330 Ø 10 mm
0,12 kg

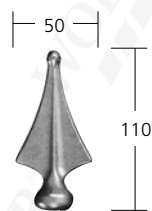

41350 Ø 25 mm
0,16 kg

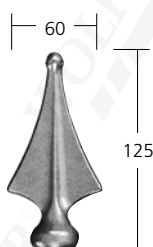

41352 Ø 31 mm
0,24 kg



41354 Ø 25 mm
0,32 kg



41356 Ø 30 mm
0,52 kg



41358 Ø 40 mm
0,96 kg

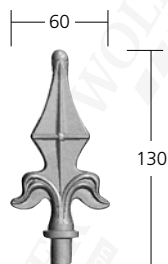

41360 Ø 11 mm
0,17 kg

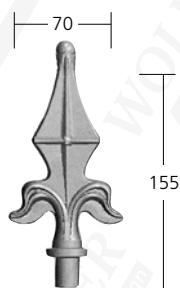

41362 Ø 16 mm
0,33 kg



41364N Ø 12 mm
0,16 kg



41365N Ø 20 mm
0,15 kg



41366N Ø 17 mm
0,32 kg

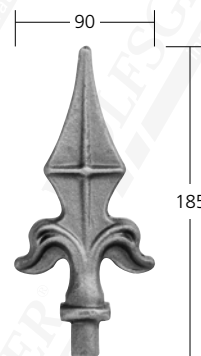

41368 Ø 19 mm
0,50 kg

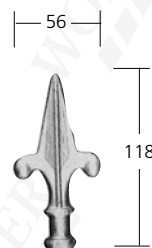

41370 Ø 21 mm
0,16 kg

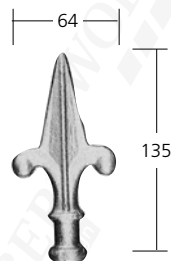

41372 Ø 24 mm
0,25 kg



41374 Ø 12 mm
0,14 kg



41376 Ø 16 mm
0,30 kg



41378 Ø 20 mm
0,45 kg

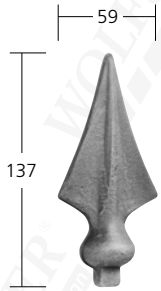

41414 \varnothing 14 mm
0,30 kg

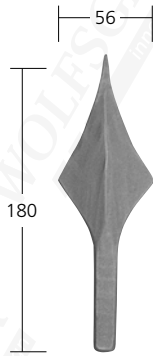

41424 \varnothing 14 mm
0,26 kg

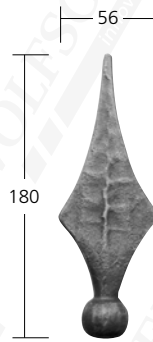

41434 \varnothing 29 mm
0,38 kg

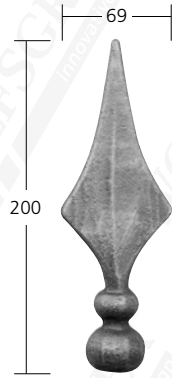

41446 \varnothing 34 mm
0,58 kg



41452 \varnothing 15 mm
0,18 kg

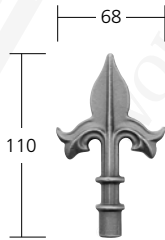

41464 \varnothing 12 mm
0,12 kg

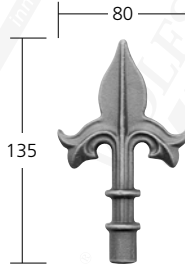

41466 \varnothing 16 mm
0,22 kg

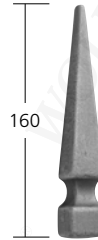

41476 \varnothing 24 mm
0,30 kg



41477 \varnothing 40 mm
1,04 kg

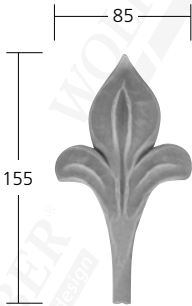

30226 \varnothing 12 mm
0,18 kg

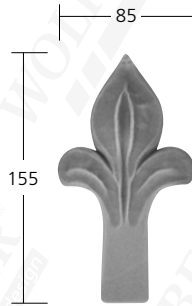

30227 30x4 mm
0,18 kg



Mat.
41486 \varnothing 12-16 mm 0,28 kg
41487 12x13 mm 0,12 kg



41498 \varnothing 12 mm
0,18 kg



	h	∅
41512	100	20x20
41514	125	25x25
41516	135	32x32
41517	150	40x40

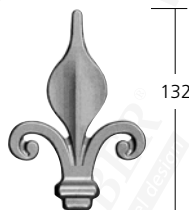

41525 ∅18X20 mm

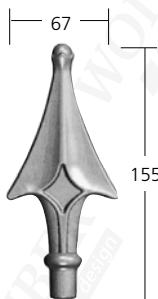

41536 ∅ 16 mm
0,34 kg

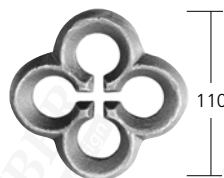

41560 Mat. 14 mm
0,42 kg

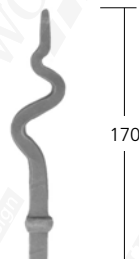

41510 ∅12mm
0,25 kg

lance con foro · Zaunspitzen mit Bohrung · spears with hole

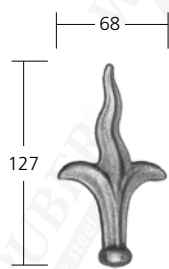

↑ foro
Bohrung
hole
∅ 12,5

41565

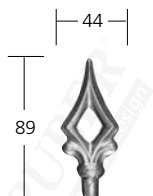

↑ foro
Bohrung
hole
∅ 12,5

41300



↑ foro
Bohrung
hole
∅ 12,5

41315

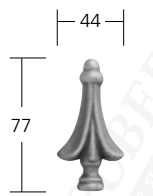

↑ foro
Bohrung
hole
∅ 12,5

41323N

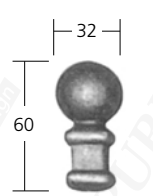

↑ foro
Bohrung
hole
∅ 12,5

41333

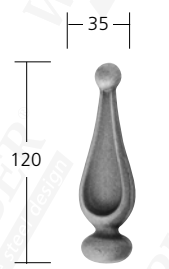

↑ foro
Bohrung
hole
∅ 12,5

41345

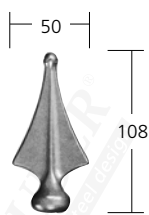

↑ foro
Bohrung
hole
∅ 12,5

41351

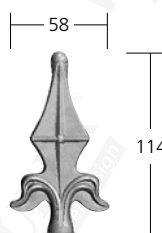

↑ foro
Bohrung
hole
∅ 12,5

41361



↑ foro
Bohrung
hole
∅ 12,5

41363N

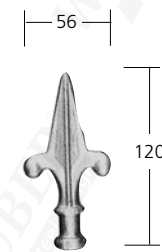

↑ foro
Bohrung
hole
∅ 12,5

41371



↑ foro
Bohrung
hole
∅ 12,5

41375



41610 $\varnothing 25$ mm
1,96 kg



41625 $\varnothing 20$ mm
0,96 kg



41630 $\varnothing 25$ mm
0,92 kg



41635 $\varnothing 25$ mm
0,58 kg



41640 $\varnothing 14$ mm
0,56 kg



41645 $\varnothing 16$ mm
1,22 kg



41655 $\varnothing 14$ mm
0,42 kg



41660 $\varnothing 14$ mm
0,33 kg



41665 $\varnothing 13$ mm
0,30 kg



41670 $\varnothing 12$ mm
0,31 kg



41675 $\varnothing 14$ mm
0,52 kg

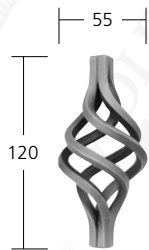

42112 \varnothing 12 mm
0,18 kg

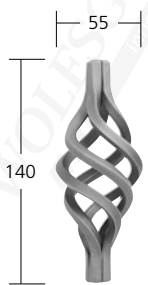

42113 \varnothing 12 mm
0,20 kg

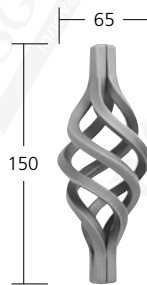

42114 \varnothing 14 mm
0,33 kg

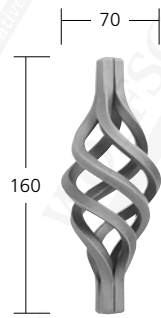

42116 \varnothing 16 mm
0,42 kg

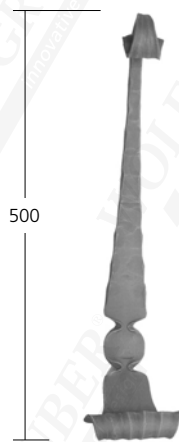

42252 Mat. 10 mm
2,10 kg



42250 Mat. 10 mm
1,60 kg



42120 \varnothing 20 mm
0,84 kg

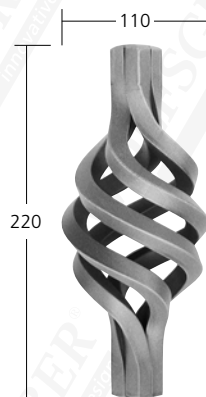

42124 \varnothing 24 mm
1,30 kg

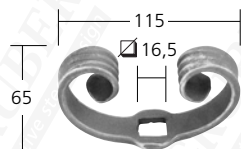

42210 Mat. 20x6 mm
0,26 kg

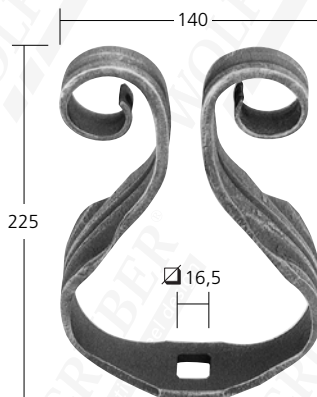

42220 Mat. 40x8 mm
0,98 kg

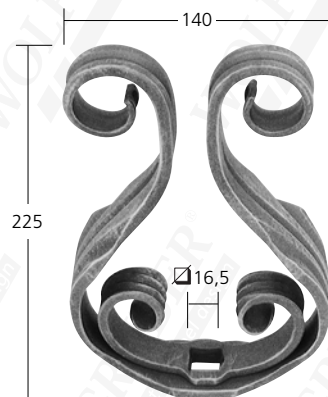

42230 Mat. 40x8 mm
1,24 kg

stampate a caldo · warm gepresst · pressed with heat



foro
Loch
hole

43112	Ø 12,5 mm	0,18 kg
43113	∅ 12,5 mm	0,18 kg
43114	Ø 14,5 mm	0,18 kg



foro
Loch
hole

43122	Ø 12,5 mm	0,21 kg
43123	∅ 12,5 mm	0,25 kg
43124	Ø 14,5 mm	0,25 kg
43126	Ø 16,5 mm	0,16 kg

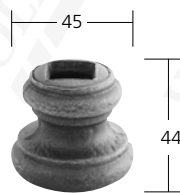

foro
Loch
hole

43215	∅ 14,5 mm	0,22 kg
43214	Ø 14,5 mm	0,22 kg
43216	Ø 16,5 mm	0,21 kg



foro
Loch
hole

43225	∅ 14,5 mm	0,30 kg
43224	Ø 14,5 mm	0,30 kg
43226	Ø 16,5 mm	0,30 kg
43227	∅ 16,5 mm	0,22 kg

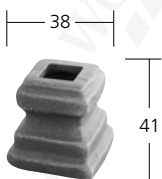

43315 0,31 kg

foro
Loch · hole ∅ 14,5 mm



43325 0,42 kg

foro
Loch · hole ∅ 14,5 mm

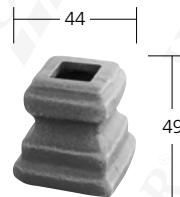

43417 0,34 kg

foro
Loch · hole ∅ 16,5 mm



43427 0,70 kg

foro
Loch · hole ∅ 16,5 mm



foro
Loch
hole

43514	Ø 14,5 mm	0,25 kg
43516	Ø 16,5 mm	0,24 kg
43515	∅ 14,5 mm	0,25 kg
43517	∅ 16,5 mm	0,24 kg



43614 0,20 kg

foro
Loch · hole Ø 14,5 mm



foro
Loch
hole

43713	∅ 12,5 mm	0,23 kg
43714	Ø 14,5 mm	0,23 kg



foro
Loch
hole

43723	∅ 12,5 mm	0,39 kg
43724	Ø 14,5 mm	0,44 kg

tornito · gedreht · turned

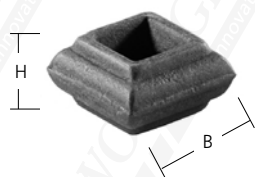

	foro Loch hole	B	H	
43813	∅12,5 mm	33	22	0,10 kg
43815	∅14,5 mm	38	22	0,12 kg

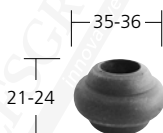

	foro Loch hole		
43832	∅ 12,5 mm	0,08 kg	
43833	∅ 12,5 mm	0,08 kg	
43834	∅ 14,5 mm	0,08 kg	
43836	∅ 14,5 mm	0,07 kg	

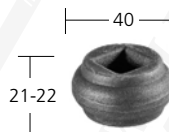

	foro Loch hole		
43822	∅ 12,5 mm	0,13 kg	
43824	∅ 14,5 mm	0,12 kg	

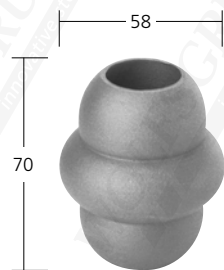

43838	0,58 kg
foro Loch · hole	∅ 25,4 mm

terminali a sfera · Geländerkugeln · railing balls



ART.	FORO LOCH HOLE	KG
43860	∅12,2 mm	0,75

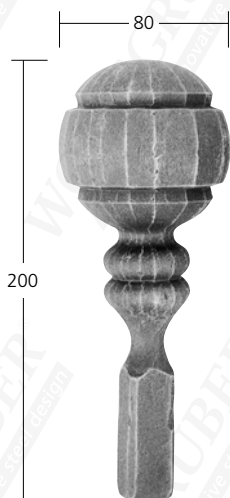

44020	∅25 mm	2,82 kg
--------------	--------	---------

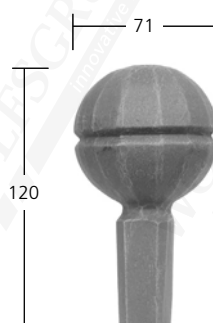

44032	2,10 kg
--------------	---------

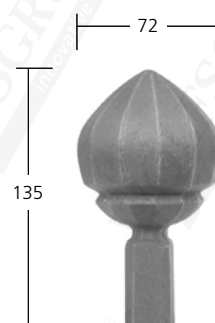

44036	1,86 kg
--------------	---------

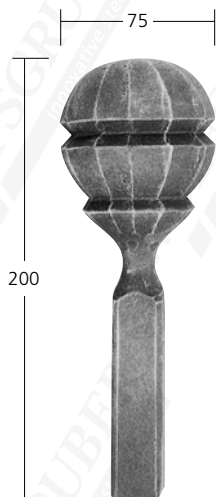

44010	∅25 mm	2,46 kg
--------------	--------	---------



44030	0,74 kg
--------------	---------



44034	0,94 kg
--------------	---------

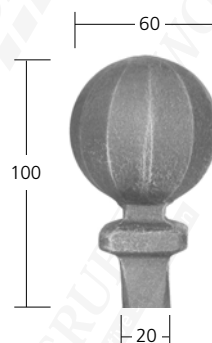

44038	1,00 kg
--------------	---------



	per tubi (pollici) für Rohre (Zoll) for tubes (inches)	spessore Stärke thickness	
44112	1"	2,0 mm	0,14 kg
44114	1 1/4"	2,0 mm	0,18 kg
44116	1 1/2"	2,0 mm	0,20 kg
44117	1 3/4"	2,0 mm	0,28 kg
44118	2"	2,0 mm	0,35 kg



	per tubi für Rohre for tubes
44144	40x40x2
44145	50x50x2
44146	60x60x2
44147	80x80x2

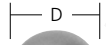

	per tubi (pollici) für Rohre (Zoll) for tubes (inches)	spessore Stärke thickness	D	
44122	1"	2,0 mm	40	0,20 kg
44124	1 1/4"	2,0 mm	45	0,25 kg
44126	1 1/2"	2,0 mm	50	0,32 kg
44127	1 3/4"	2,0 mm	55	0,40 kg
44128	2"	2,0 mm	60	0,48 kg

copripilastri · Abdeckkappen · pillar covers

	A mm	H mm	
44230	30	12	0,02 kg
44240	40	13	0,03 kg
44250	50	15	0,06 kg
44260	60	16	0,08 kg
44280	80	19	0,13 kg
44290	100	22	0,18 kg
44292	120	23	0,21 kg

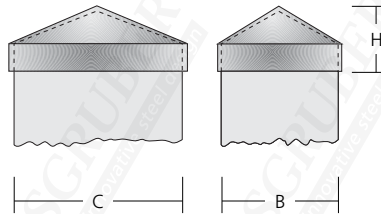
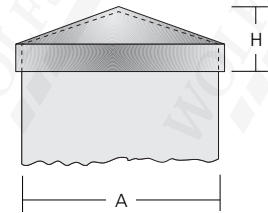
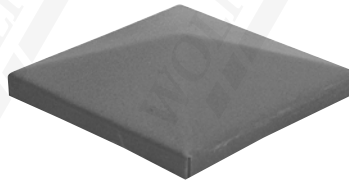

	BxC mm	H mm	
44323	20x30	12	0,01 kg
44324	20x40	12	0,02 kg
44335	30x50	14	0,04 kg
44336	30x60	14	0,04 kg
44346	40x60	16	0,06 kg
44348	40x80	16	0,06 kg
44351	50x100	18	0,10 kg

	Ø D mm	tubo Rohr tubes	H mm	
44430	30		19	0,02 kg
44433	33	1"	19	0,02 kg
44442	42	1 1/4"	22	0,03 kg
44448	48	1 1/2"	28	0,05 kg
44460	60	2"	27	0,06 kg
44476	76	2 1/2"	29	0,11 kg
44489	89	3"	27	0,12 kg
44491	101	3 1/2"	28	0,14 kg
44494	114	4"	29	0,18 kg

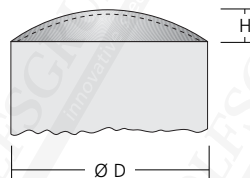
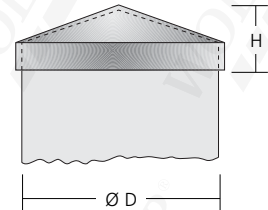

	Ø D mm	tubo Rohr tubes	H mm	
44533	33	1"	6	0,01 kg
44542	42	1 1/4"	7	0,02 kg
44548	48	1 1/2"	8	0,03 kg
44552	52	1 3/4"	8	0,03 kg
44560	60	2"	9	0,04 kg



spessore · Stärke · thickness: 6 mm

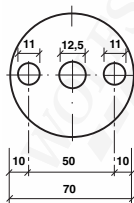
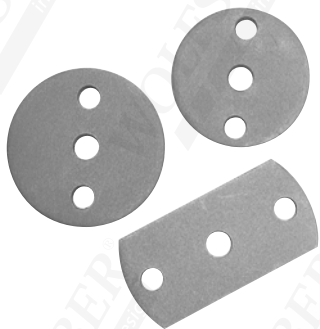

45070 0,17 kg

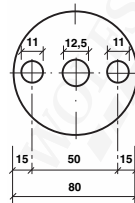

45080 0,22 kg

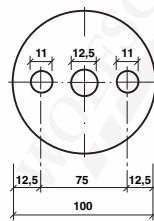

45100 0,34 kg

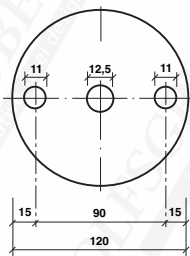

45120 0,51 kg

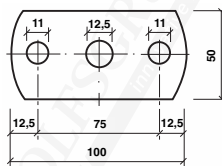

45200 0,21 kg

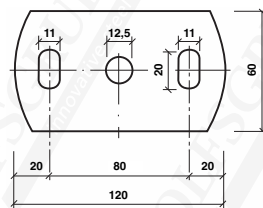

45220 0,28 kg

attacchi per saldare grezzi
Anschweißblaschen roh
welding latches raw

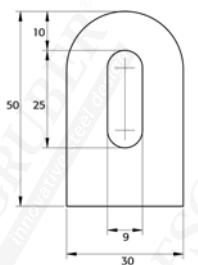

54305 Mat. 6 mm

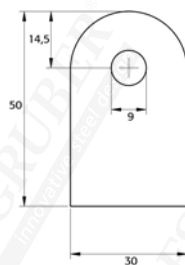

54306 Mat. 6 mm

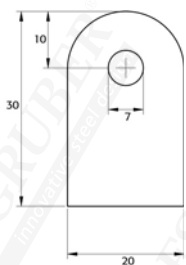

54307 Mat. 5 mm

rondelle · Ronden · washers

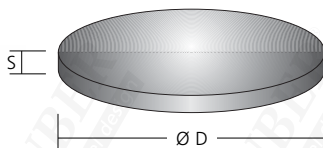
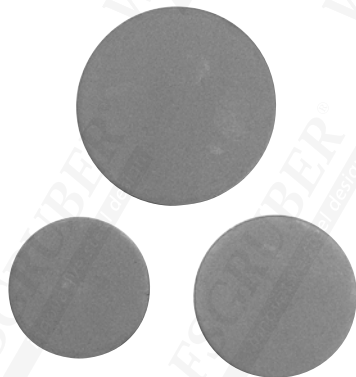

	Ø D mm	S mm	
45333	33	4	0,02 kg
45335	35	4	0,03 kg
45340	40	4	0,04 kg
45342	42	4	0,04 kg
45345	45	4	0,05 kg
45348	48	4	0,05 kg
45350	50	4	0,06 kg
45352	52	4	0,06 kg
45360	60	4	0,08 kg
45370	70	6	0,18 kg
45380	80	6	0,23 kg
45390	100	6	0,36 kg
45392	120	6	0,53 kg

sfere piene
Vollkugeln
solid spheres

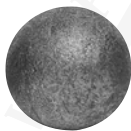

Ø

45515	15 mm	0,01 kg
45520	20 mm	0,03 kg
45525	25 mm	0,06 kg
45530	30 mm	0,12 kg
45535	35 mm	0,17 kg
45540	40 mm	0,27 kg
45550	50 mm	0,50 kg
45560	60 mm	0,91 kg
45570	70 mm	1,97 kg
45580	80 mm	2,16 kg



sfere con foro cieco
Kugeln mit Sackloch
balls with blind hole

	Mat.	foro Loch hole
43918	Ø20	Ø8,3
43928	Ø25	Ø12,2
43933	Ø30	Ø12,2
43938	Ø35	Ø12,2
43939	Ø35	Ø14,3

borchie con foro passante
Zierhülsen mit Durchgangsbohrung
envelopings bodies with a hole



	Mat.	foro Loch hole
43925	Ø25	Ø12,2
43930	Ø30	Ø12,2
43935	Ø35	Ø12,2
43936	Ø35	Ø14,3

sfere cave
Hohlkugeln
hollow spheres



mezze sfere cave
Halbkugeln
hollow hemispheres

	Ø	
45750	50 mm	0,11 kg
45760	60 mm	0,18 kg
45770	70 mm	0,29 kg
45780	80 mm	0,35 kg
45790	100 mm	0,57 kg
45792	120 mm	1,01 kg
45794	150 mm	1,20 kg
45796	200 mm	1,80 kg

	Ø	
45834	33,7 mm	0,03 kg
45842	42,4 mm	0,04 kg
45848	48,3 mm	0,05 kg
45850	50 mm	0,06 kg
45860	60 mm	0,09 kg
45870	70 mm	0,14 kg
45880	80 mm	0,18 kg
45890	100 mm	0,29 kg
45892	120 mm	0,51 kg

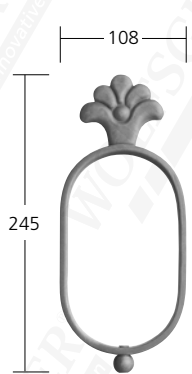

46010 Mat. 12x5 mm
0,36 kg

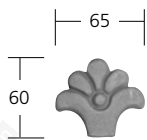

46012 Mat. 6 mm
0,10 kg

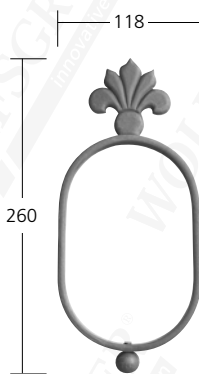

46020 Mat. 14x6 mm
0,44 kg

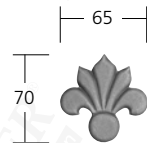

46022 Mat. 6 mm
0,10 kg



	Mat. Ø	H	kg
46030	12 mm	500 mm	0,49
46032	12 mm	1000 mm	0,93



	Mat. Ø	H	kg
46035	12 mm	500 mm	0,45
46037	12 mm	1000 mm	0,89



46038	H: 500 mm
46039	H: 1000 mm

Ø 12 mm

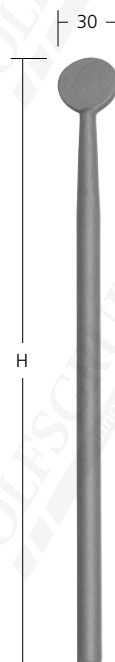

	Mat. Ø	H	kg
46040	12 mm	500 mm	0,49
46042	12 mm	1000 mm	0,93

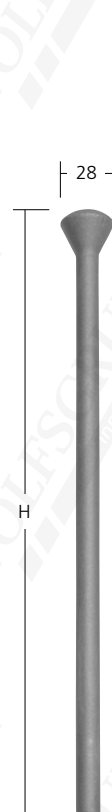

	Mat. Ø	H	kg
46045	12 mm	500 mm	0,43
46047	12 mm	1000 mm	0,87

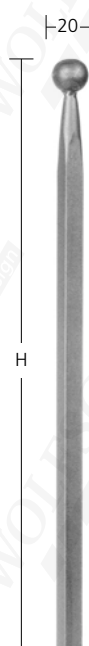

46050	H: 500 mm
46052	H: 1000 mm

Ø 12 mm

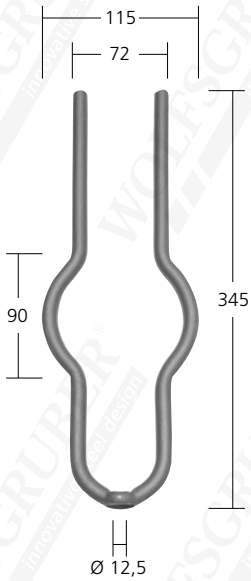

46110 Mat. Ø 12 mm
0,62 kg



46120 Mat. Ø 12 mm
0,30 kg



46130 Mat. 14x6 mm
0,24 kg

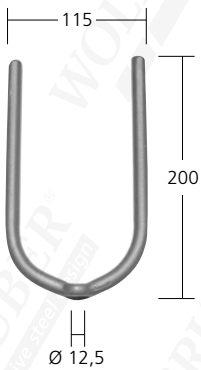

46115 Mat. Ø 12 mm
0,40 kg

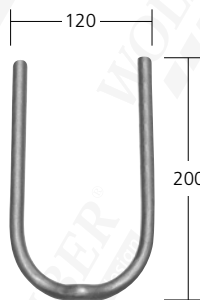

46125 Mat. Ø 12 mm
0,40 kg

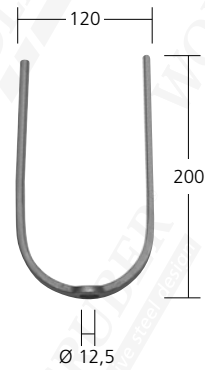

46135 Mat. 14x6 mm
0,31 kg

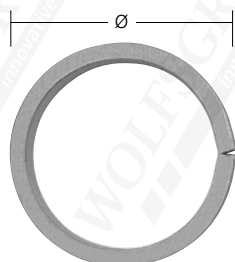

	Ø mm	Mat. mm	
46350	118	12x5	0,17 kg
46310	108	12x6	0,15 kg
46312	100	12x6	0,14 kg
46314	120	12x6	0,17 kg
46374	100	12x12	0,24 kg
46373	110	12x12	0,26 kg
46375	118	12x12	0,28 kg
46315	100	14x6	0,19 kg
46355	118	14x6	0,23 kg
36530	100	16x8	0,27 kg
36535	120	16x8	0,33 kg
46325	108	Ø 12	0,28 kg
46326	110	Ø 12	0,29 kg
46365	118	Ø 12	0,31 kg

cerchi ovali · Ovale Ringe · oval circles

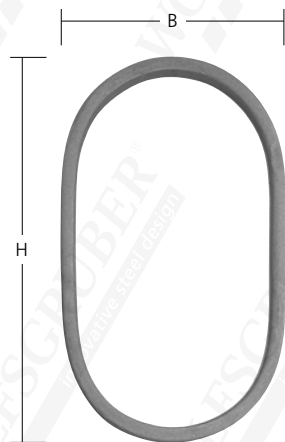

	B mm	H mm	Mat. mm	
46410	108	160	12x5	0,20 kg
46415	100	160	14x6	0,27 kg
46425	108	160	Ø 12	0,36 kg
46450	118	180	12x5	0,22 kg
46455	118	180	14x6	0,31 kg
46465	118	180	Ø 12	0,40 kg

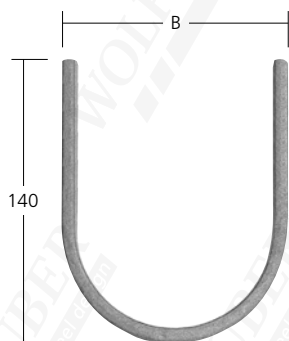

semicerchi · Halbringe · half rings

	B mm	Mat. mm	
46510	108	12x5	0,15 kg
46515	100	14x6	0,21 kg
46525	108	Ø 12	0,28 kg
46550	118	12x5	0,16 kg
46555	118	14x6	0,23 kg
46565	118	Ø 12	0,30 kg

sostegni inferriata · Fenstergitterhalter · iron window bar holder

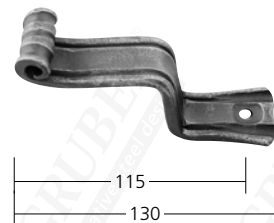

48010 Mat. 10 mm
0,50 kg

48015 Mat. 6 mm
0,22 kg

48020 Mat. 7 mm
0,30 kg



47102 1,23 kg



47101 2,16 kg

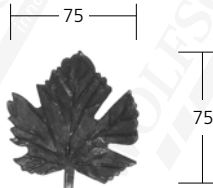

47112 Mat. 3 mm
0,12 kg

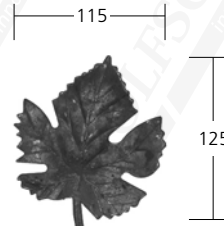

47122 Mat. 3 mm
0,22 kg

rose · Rosen · roses



47210 0,55 kg

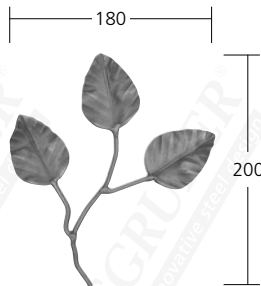

47215 0,13 kg



47220 0,22 kg

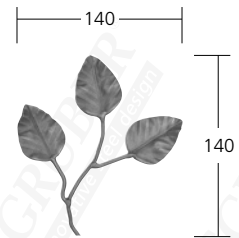

47225 0,06 kg



VITI DI SICUREZZA · SICHERHEITSSCHRAUBEN · SAFETY SREWS

zincate · verzinkt · galvanized

tassello in nylon per murature forate
Nyloodübel für Hohlraummauern
dowl of nylon for hollow walls

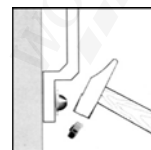
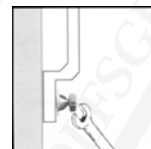

Ø 12



M8

48110 Mat. M8x95 mm
0,05 kg

tassello in acciaio per murature compatte
Stahldübel für Betonmauern
dowl of steel for concrete walls

Ø 12



M8

48120 Mat. M8x95 mm
0,06 kg

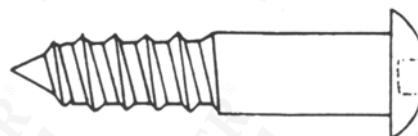

perno esagonale
Sechskantbolzen
hexagon bolts



lunghezza
Länge
length

48220	Ø 8	70 mm	0,02 kg
48230	Ø 8	90 mm	0,03 kg
48240	Ø 10	80 mm	0,04 kg
48250	Ø 10	100 mm	0,05 kg
48260	Ø 10	130 mm	0,06 kg



48500 Mat. Ø 5 mm
0,01 kg

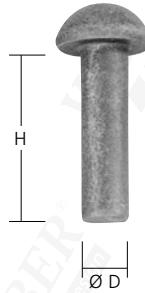

	Ø D mm	H mm	pezzi/kg St./kg pieces/kg
48545	6	25	115
48546	6	30	102
48548	6	40	85
48554	8	20	64
48555	8	25	56
48556	8	30	51
48558	8	40	43
48565	10	25	47
48566	10	30	41
48568	10	40	33

sfere ribattibili
Annietkugeln
spheres to be rivetted

perni a sfera
Kugelpopfbolzen
ball end pins

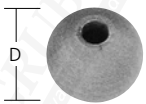

	Ø D mm	foro Loch hole
48713	13	6
48716	16	6
48719	19	6
48722	22	6

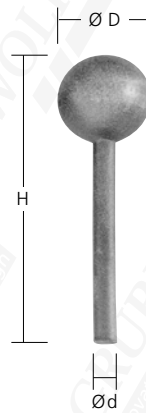

	Ø D mm	Ø d mm	H mm
48810	10	5	30
48813	13	5,5	60
48816	16	5,5	65
48819	19	5,5	70
48822	22	5,5	70

**SERRAMENTI
BESCHLÄGE
MOUNTINGS**

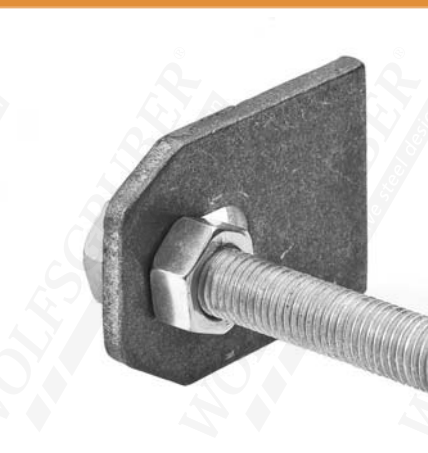

WOLFSGRUBER



innovative steel design

lock cover plates, lock cases

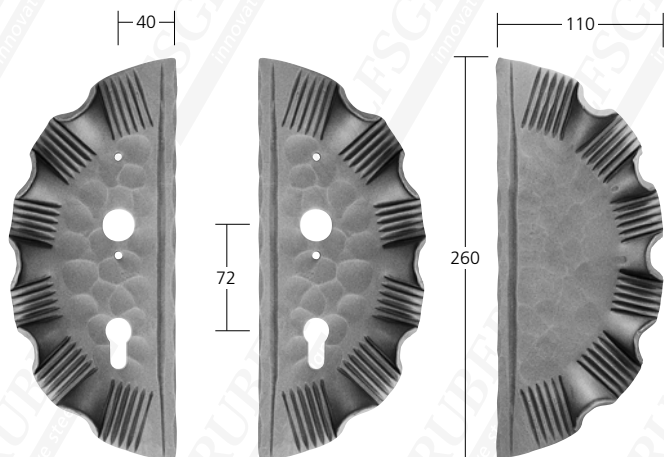

51110 Mat. 4 mm
0,90 kg

51111 Mat. 4 mm
0,90 kg

51112 Mat. 4 mm
0,94 kg

utilizzabili a destra e sinistra
links und rechts verwendbar
usable left and right

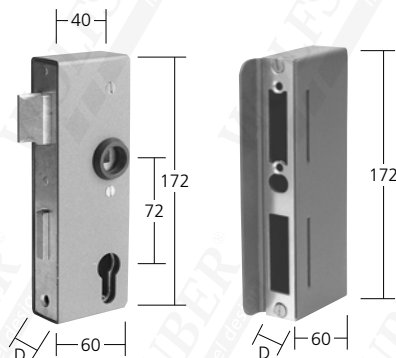

51340 D 30 mm · 1,02 kg
51345 D 40 mm · 1,10 kg

51810 D 30 mm · 0,64 kg
51820 D 40 mm · 0,64 kg

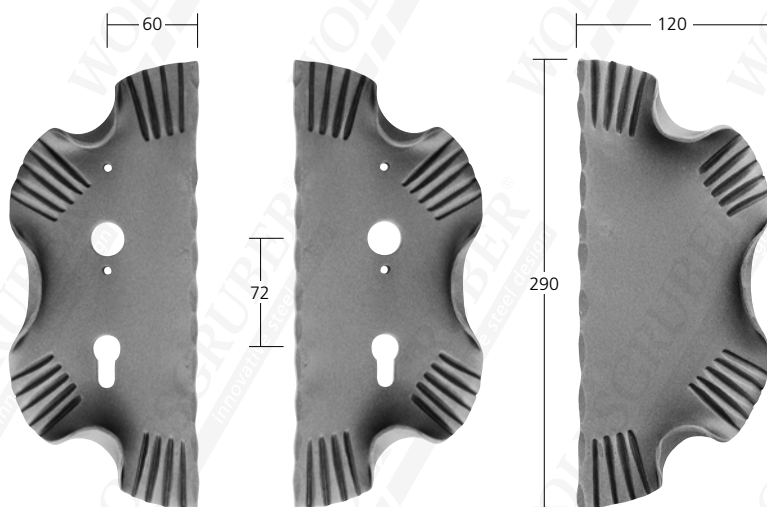

51120 Mat. 4 mm
0,70 kg

51121 Mat. 4 mm
0,70 kg

51122 Mat. 4 mm
0,73 kg

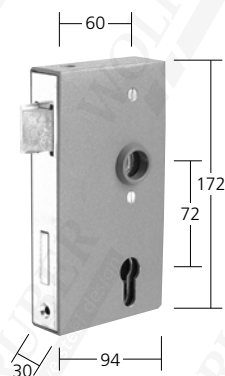

51360 1,48 kg

serratura a gancio
Hakenschloß
hook lock

elettroserratura con sblocco - Elektrische Türöffner mit Entriegelung
electric lock with unlock
6-12 V



51610 0,32 kg



51611 0,32 kg

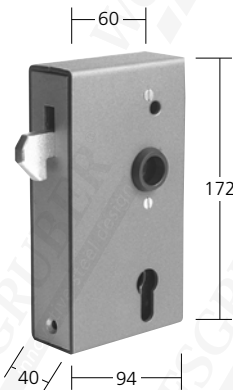

51460 1,78 kg

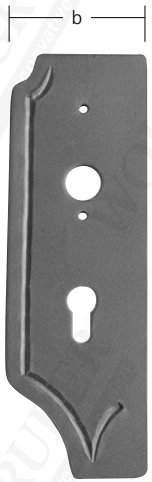

d=40
b=85

51130

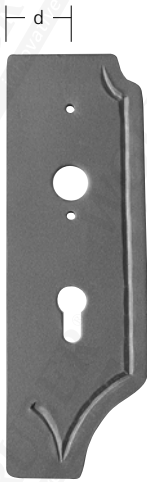

51131



51133

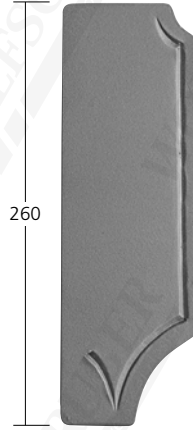

51132

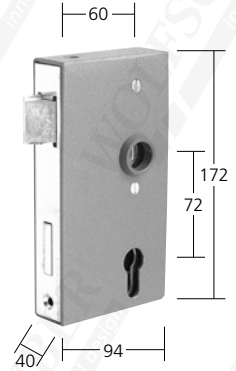

Ferro
Eisen
Iron
51350 1,02 kg

INOX AISI 304
INOX V2A
Iron Steel V²A
68450 1,02 kg

d=60
b=105

51140

51141

51143

51142

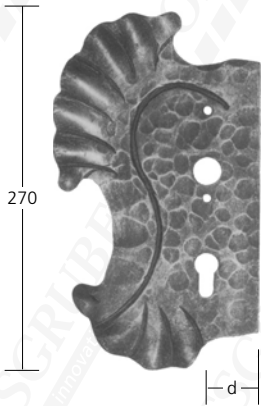

d=40

51150

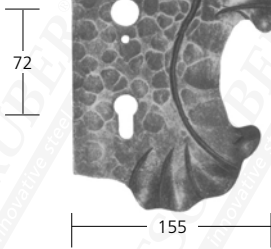

51151

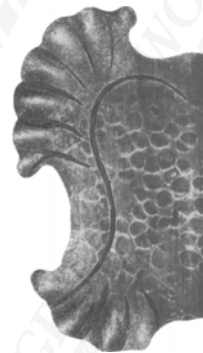

51152

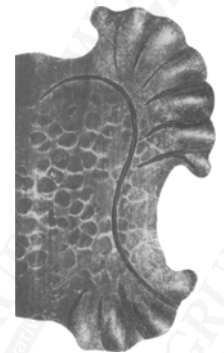

51153

d=60

51156

51157

serrature per tubolari
Rohrrahmenschlösser
mortice locks

zincate · verzinkt · galvanized

	A	B
51524	24 mm	37 · 0,50 kg
51530	30 mm	45 · 0,52 kg
51540	40 mm	55 · 0,55 kg

utilizzabili a destra e sinistra
links und rechts verwendbar
usable left and right



esempio d'impiego
Anwendungsbeispiel
example of application

51810

51610





52110 0,40 kg



52120 0,22 kg

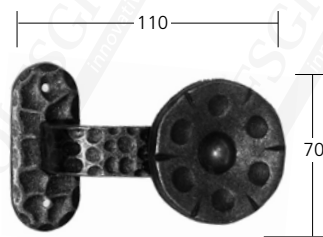

52132 0,33 kg

copricilindri e rosette · Schlüsselschilder und Drückerrosetten · keyhole surrounds



52310 Mat. 5 mm
0,06 kg



52315 Mat. 3 mm
0,04 kg



52320 Mat. 5 mm
0,06 kg



52325 Mat. 3 mm
0,04 kg

rosette di sicurezza
Sicherheitsrosette
safety rosettes



52330 Mat. 10 mm
0,13 kg



52335 Mat. 10 mm
0,13 kg

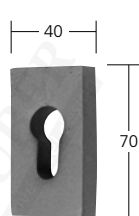

52345 Mat. 15 mm
0,28 kg

cilindro · Zylinder · cylinder

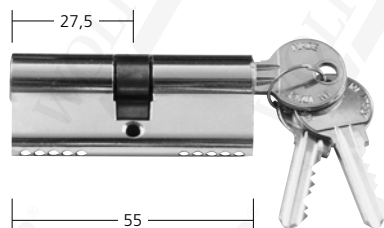

52450 0,20 kg

perno · Stift · pin



52400 Mat. 8x8x100 mm
0,04 kg

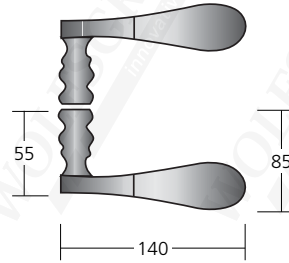

52611 0,34 kg

52610

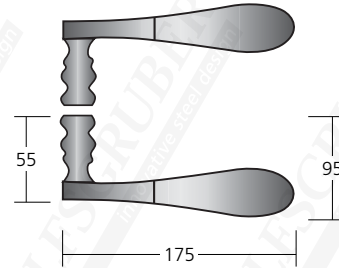

52613 0,38 kg

52612

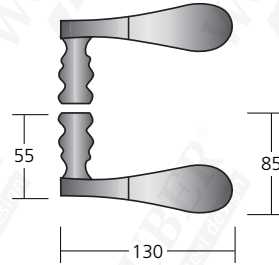

52615 0,32 kg

52614

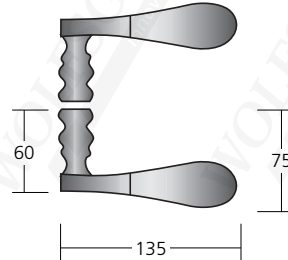

52617 0,32 kg

52616

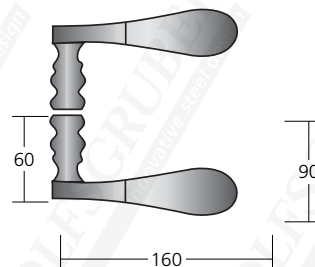

52619 0,42 kg

52618



MANIGLIA · HANDGRIFF · HANDLE

verniciata nero · schwarz lackiert · vernished black

INOX AISI 304 satinato
Edelstahl W.1.4301 geschliffen
Stainless steel AISI 304 satined

confezione singola
Lieferung Einzeln
single confection



133

ART.

* **67217**

Drückerstift

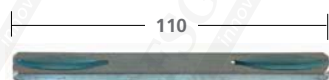

110

ART.

67254

maniglione tubolare per portoni
Rohrhandgriff für Tore
tubular handle for folding gates

52780 0,80 kg

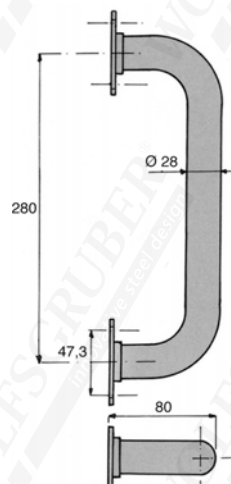

* mobile usabile destra e sinistra · beweglich beidseitig verwendbar · mobile left-right usable





53110 1,90 kg

53111 1,90 kg

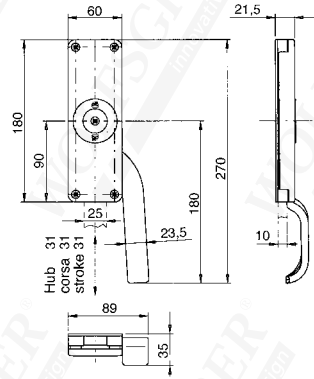

53120 0,90 kg

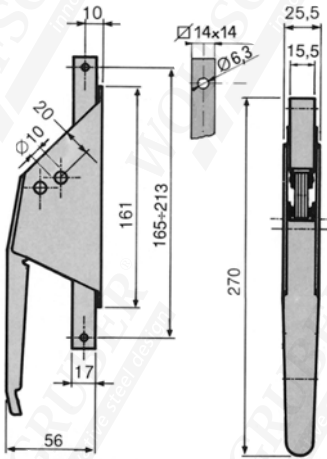

53130 0,50 kg

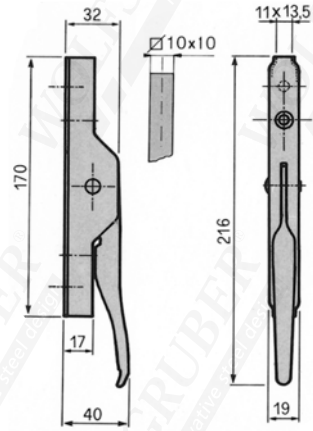

crichetto
Oberlichtsnapper
catches

chiavistello con chiavetta
Riegel mit Schlüssel
ratch with key



53210 0,09 kg

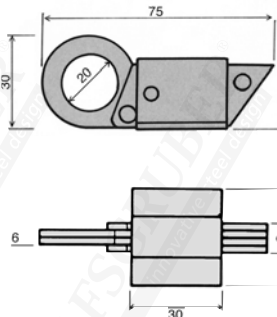

53250 0,08 kg

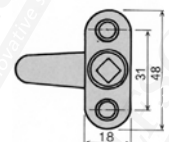
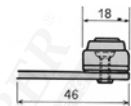



53305 1,85 kg

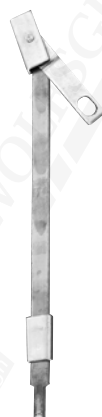

53310 0,40 kg

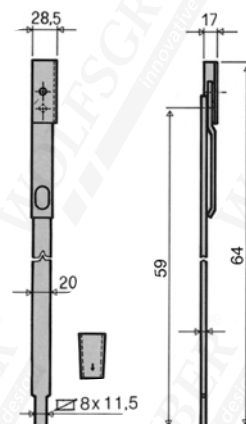

cremagliera rettangolare zincata
Zahnstangen verzinkt
zinked rectangular rack

attacchi per cremagliera
Distanzhülsen für Zahnstangen
fastening for rectangular rack



lunghezza
Länge
length

53440 1000 mm - 2,00 kg/m

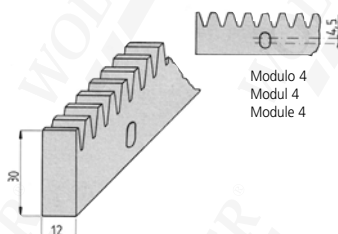

Modulo 4
Modul 4
Module 4



53442 0,06 kg

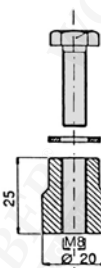

battenti d'arresto - Toranschläge - stop battents

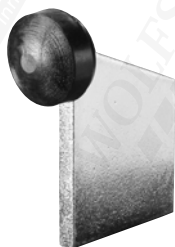

53510 0,60 kg

zincato
verzinkt
zinked

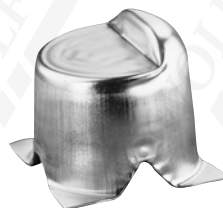
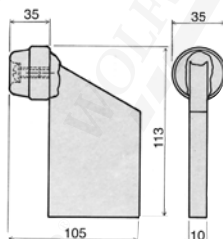

53520 0,35 kg

zincato
verzinkt
zinked

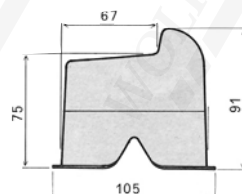

53530 12x35x100



con rondella in ottone
mit Messingbeilagscheibe
with enclosed brass-ring

con cuscinetto a sfera
mit Kugellager
with ball-bearing



54114 0,06 kg



54116 0,10 kg



54120 0,20 kg



54124 0,34 kg

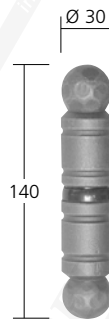

54130 0,64 kg

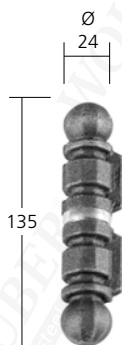

54125 0,37 kg

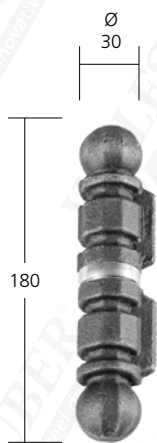

54131 0,71 kg



		A	B	
54240	M 22 x 1,5	80	190	kg 1,09
54241	M 20 x 1,5	80	130	kg 0,64

piastra per cardini
Anschweißband
welding strip

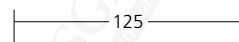

con rondella in ottone
mit Messingbeilagscheibe
with enclosed brass-ring

con cuscinetto a sfera
mit Kugellager
with ball-bearing



54220 0,20 kg



54224 0,32 kg



54230 0,62 kg



54010 Mat. 5 mm
0,52 kg

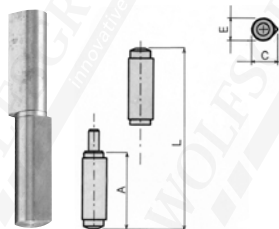

con perno in ottone
mit Messingdorn
with brass pivot

	L	A	C	E	
54312	78,5	38,5	14	12	0,07 kg
54314	100	49	16	14	0,12 kg
54316	120,5	59	18	16	0,19 kg

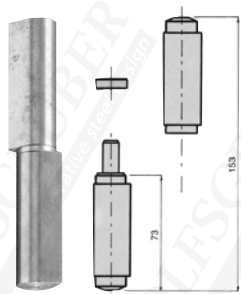

con perno in ottone e cuscinetto
mit Messingdorn und Kugellager
with brass pivot and bearing

54422 0,46 kg

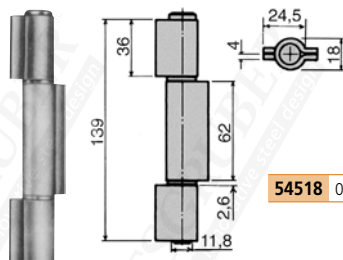

54518 0,31 kg

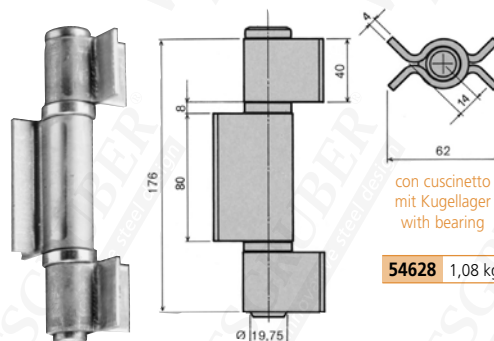

con cuscinetto
mit Kugellager
with bearing

54628 1,08 kg

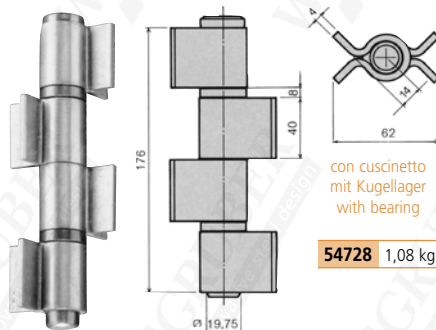

con cuscinetto
mit Kugellager
with bearing

54728 1,08 kg

regolabili, zincati · verstellbar, verzinkt · adjustable, galvanized

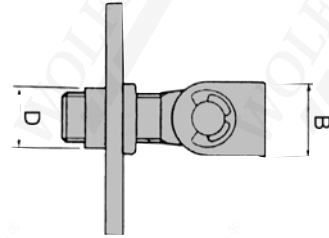
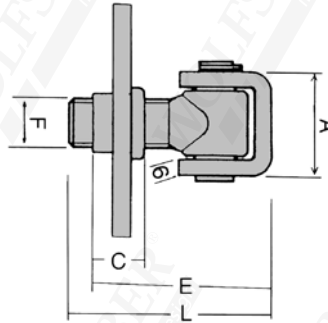
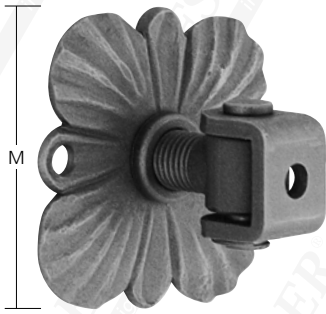

	F	M	A	B	C	D	E	L	
55010	M 20	100	40	30	21	25	60-94	83	0,70 kg
55014	M 24	130	47	35	26	29	73-113	97	1,22 kg

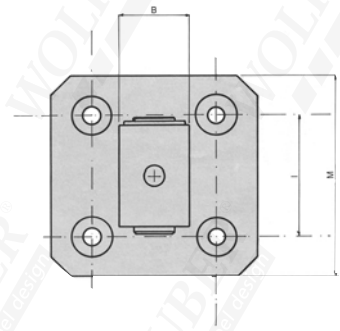
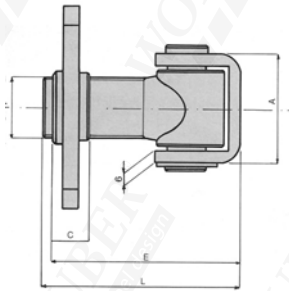

	F	M	A	B	C	E	L	I	
55020N	M 20	100	40	32	17,5	60-100	104	70	0,80 kg
55024N	M 24	100	44	36	18,5	65-92	95	70	0,92 kg

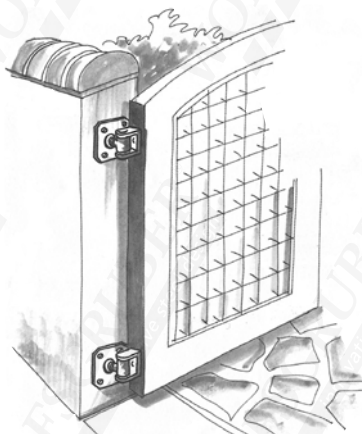

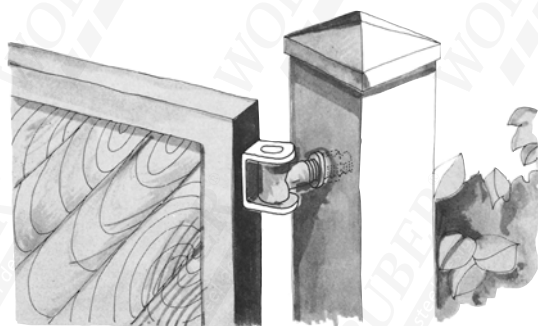
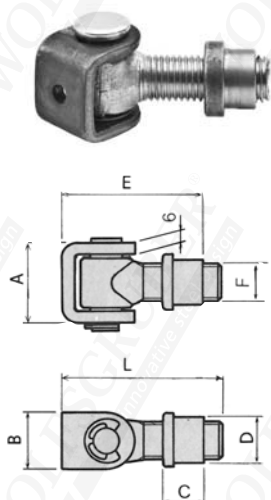

	F	A	B	C	D	E	L	
55111N	M 16	33	25	21	21	57-78	82	0,26 kg
55110	M 20	40	32	21	25	63-100	105	0,46 kg
55114N	M 24	44	36	26	29	72-90	95	0,62 kg

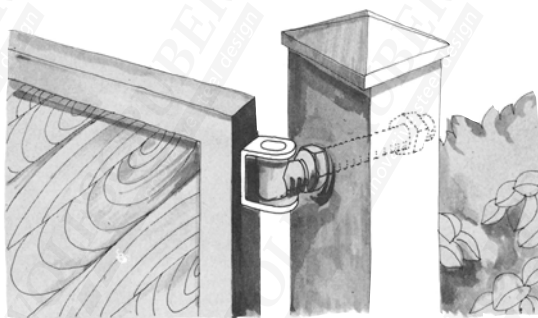
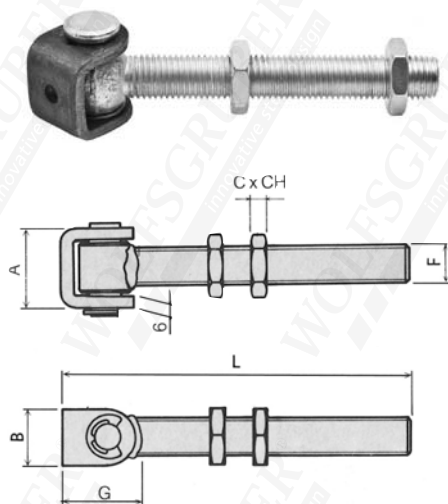

	F	A	B	C	CxCH	G	L	
55121N	M 16	33	25	8	30	34	178	0,38 kg
55120N	M 20	40	32	9	30	40	178	0,64 kg
55124N	M 24	44	35	10	36	43	178	0,88 kg

regolabili, zincati · verstellbar, verzinkt · adjustable, galvanized

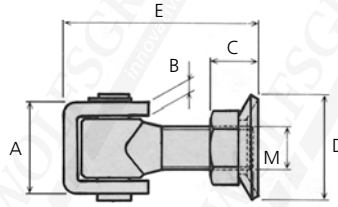

	M	A	B	C	D	E	
55211N	M 16	34x25	5	21	∅ 46	57-82	0,28 kg
55210N	M 20	40x32	6	25	∅ 47	70-105	0,50 kg

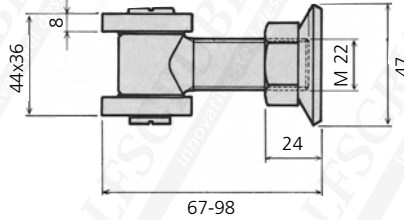
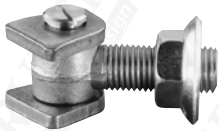
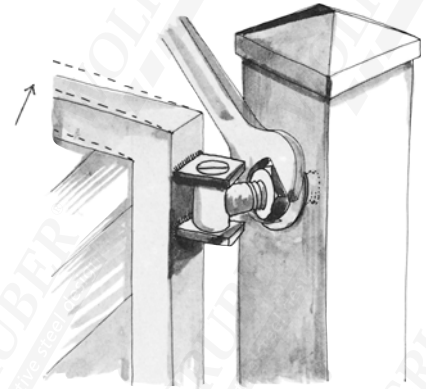

55222N 0,56 kg

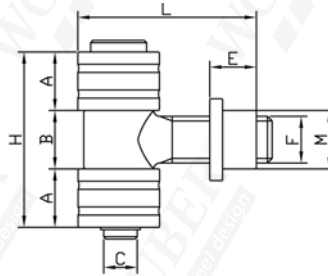
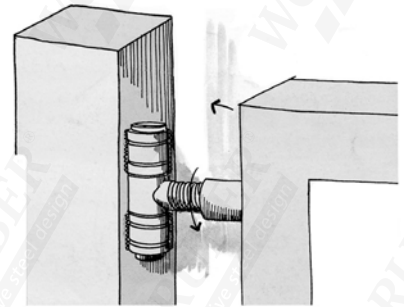

	F	A	B	C	D	E	M	H	L
54250	M 18	25	25	14,5	35	20	25	85	55-78
54252	M 20	25	25	14,5	35	20	25	85	56-82
54254	M 24	30	35	19,5	40	26	29	105	68-95

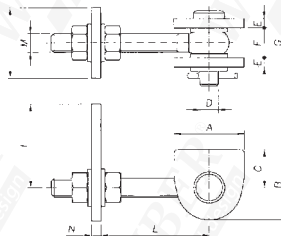
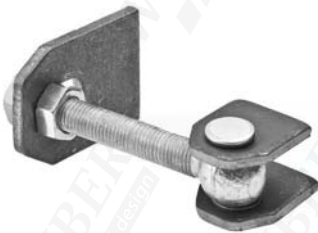
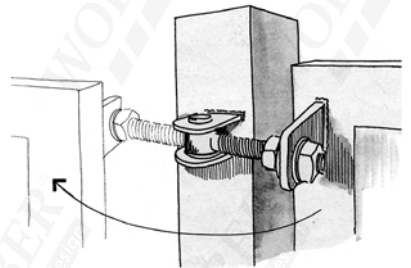

	F	A	B	E	G	H	I	L	N	
54261N	M12	40	51	5	27	60	54-68	31-100	5,5	0,50 kg
54260N	M16	40	51	6	35	60	53,5-69,5	41-97	7,5	0,74 kg
54262N	M20	70	65	7	43	60	70-107	53,5-103,5	8	1,34 kg
54264N	M24	70	65	7,5	50	71	88-111	56,5-100	11,5	1,90 kg

regolabili · zincati · verstellbar, verzinkt · adjustable, galvanized

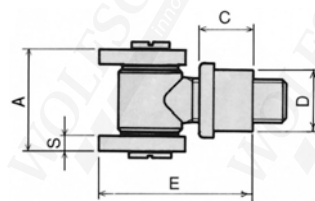
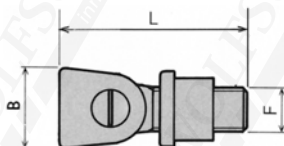
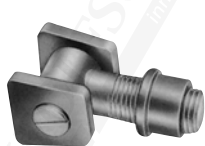

	F	A	B	C	D	E	L	S
55322	M 22	44	38	20,5	27	60-100	90	8
55327	M 27	60	40	26	33	60-100	107	10

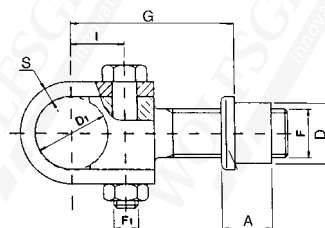

	F	D ₁	D	F ₁	G	H	I	S	A
55420	M 20	30	25	M 10	44/68	30	21	6	20,5 0,49 kg
55430	M 30	40	36	M 12	70/110	40	34	6	24 1,20 kg

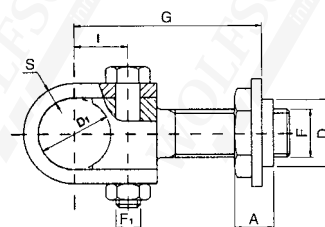

	F	D ₁	D	F ₁	G	H	I	S	A
55440	M 20	30	28	M 10	50/78	30	21	6	16 0,53 kg
55450	M 30	40	43	M 12	70/110	40	34	6	24 1,33 kg

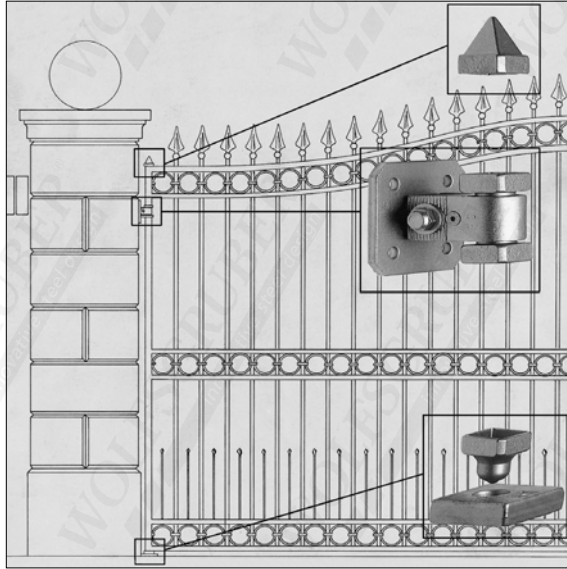

55540 3,12 kg



1 x

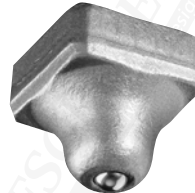
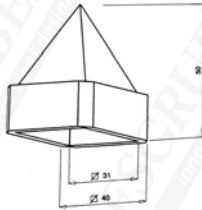

1 x

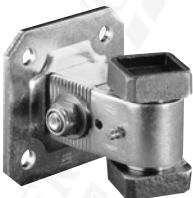
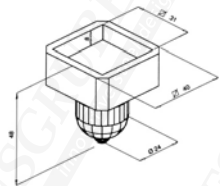

1 x

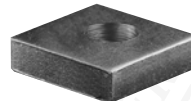
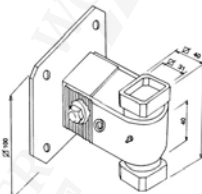

1 x

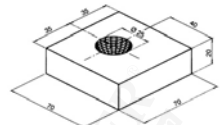



PERNO CON PIASTRA BASE · LAGERDORN MIT BODENPLATTE

pivot with base plate

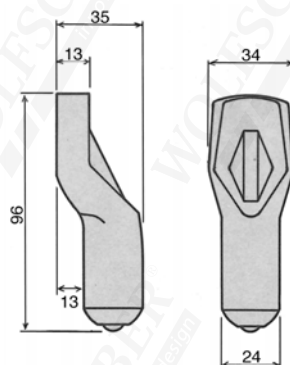
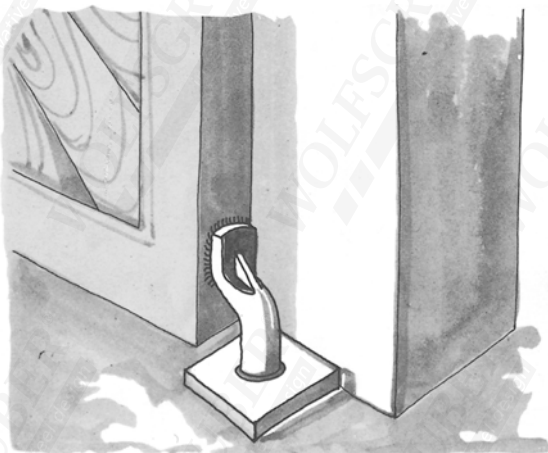

55590 0,49 kg

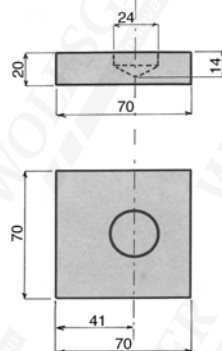

cementati · einsatzgehärtet · cemented

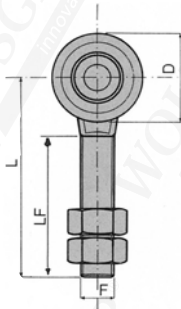

	D	F	LF	L	portata Tragkraft Capacity
58510	24	M8	30	48	0,08 kg 30 kg
58615	44	M12	58	92	0,28 kg 250 kg

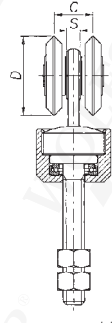
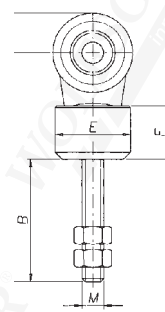

	A	B	C	D	M	portata Tragkraft Capacity
58550	63	30	22	24	M8	50 kg
58655	128	69	22	44	M12	250 kg

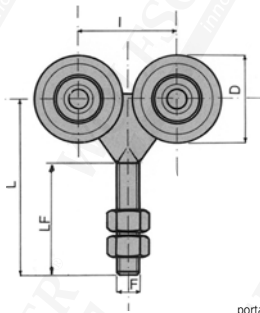

	D	F	LF	L	I	portata Tragkraft Capacity
58520	24	M8	30	48	30	0,14 kg 50 kg
58625	44	M12	58	95	50	0,44 kg 250 kg

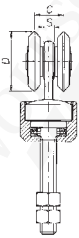
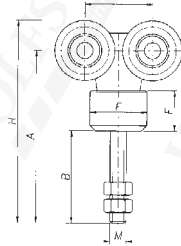

	A	B	C	D	M	I	portata Tragkraft Capacity
58560	63	30	22	24	M8	30	50 kg
58665	128	69	22	44	M12	50	250 kg

monorotaie · Laufschienen · tracks

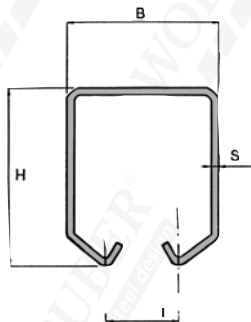

	B	H	I	S	lunghezza Länge length
58500	34,4	32,5	21,5	1,5	3m
58501	34,4	32,5	21,5	1,5	6m
58600	43	53	22	2,5	3m
58601	43	53	22	2,5	6m

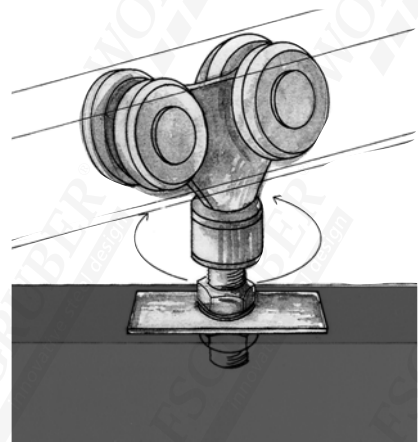

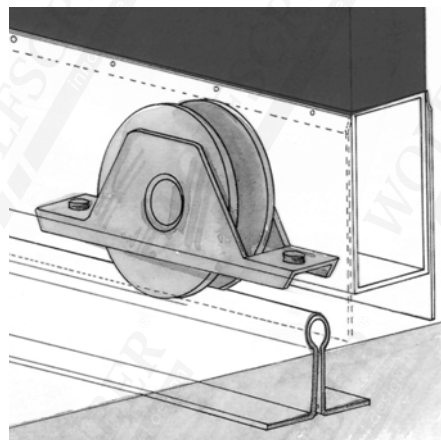
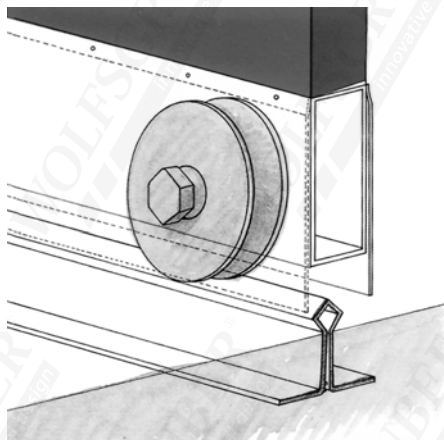

lunghezza
Länge
length

58100 3000 mm · 11,85 kg

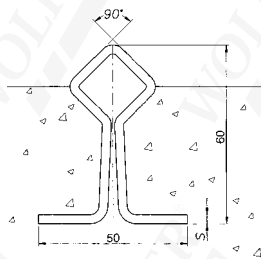

lunghezza
Länge
length

58101 6000 mm · 23,70 kg

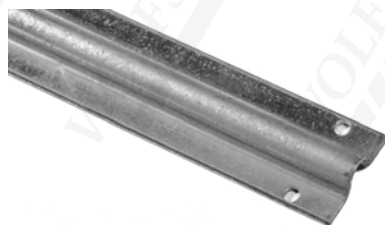

lunghezza
Länge
length

58210 3000 mm · 4,62 kg

58211 6000 mm · 9,24 kg

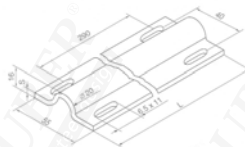

lunghezza
Länge
length

58200 3000 mm · 11,00 kg

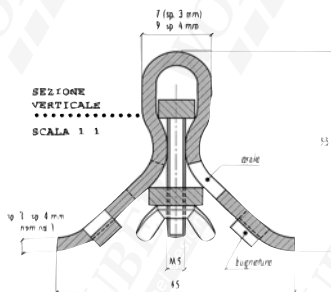

lunghezza
Länge
length

58201 6000 mm · 22,00 kg



58203

Esempio
Beispiel
Example



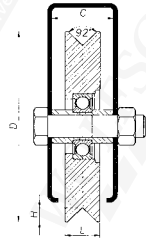

V gola
Rille
groove

	D	C	F	H	L	portata Tragfähigkeit load capacity
58120	60	24	M10x45	7	17	250 kg
58125	78	34	M14x70	7,5	20	300 kg
58130	98	34	M14x70	8,5	21	380 kg
58135	117	34	M14x70	8,5	21	410 kg
58140	137	44	M16x70	9	25	500 kg

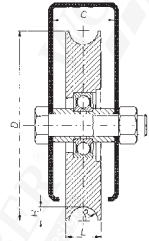

O gola
Rille
groove

	D	C	F	H	L	portata Tragfähigkeit load capacity
58230	98	34	M14x70	9,5	24	380
58235	117	34	M14x70	9,5	25	410
58240	137	44	M16x70	9,5	25	500



V gola
Rille
groove

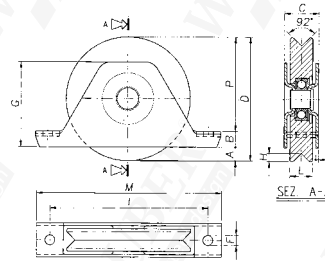

	D	A	B	C	F	G	H	I	L	M	P	S	portata Tragfähigkeit load capacity
58160	88	8,5	14,5	32	9	70	8,5	130	21	154	65	3	200 kg
58165	117	16,5	15	37	9	80	10	155	25	185	85,5	3	250 kg



O gola
Rille
groove

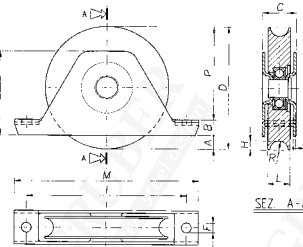

	D	A	B	C	F	G	H	I	L	M	P	R	portata Tragfähigkeit load capacity
58260	88	8,5	14,5	32	9	70	9,5	130	24	155	65	10,3	200 kg
58265	117	16,5	15	37	9	80	9,5	155	25	185	85,5	10,3	250 kg

accessoires for gate carriage

carrello · Wagen · carriage

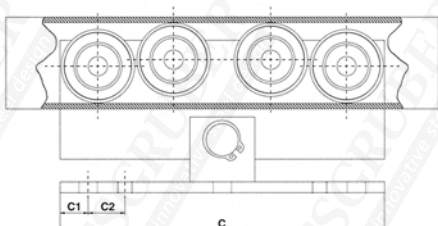
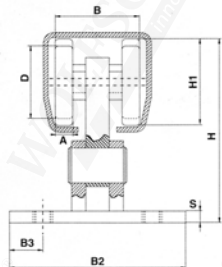

58450
58350

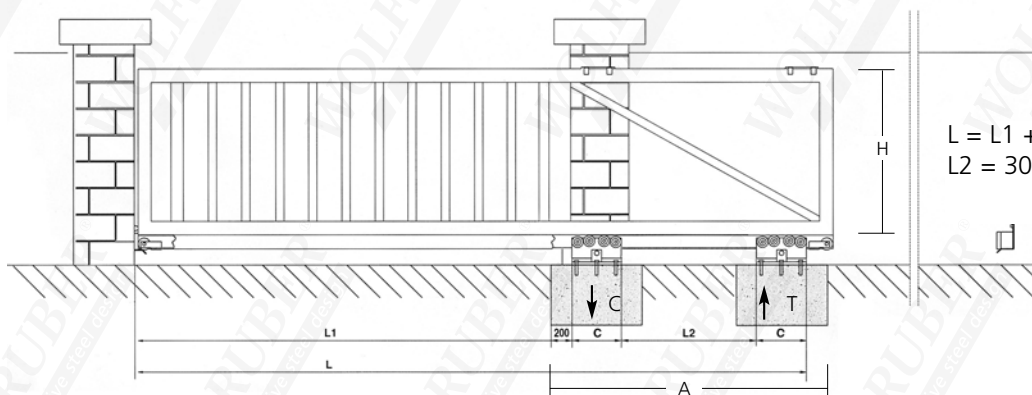
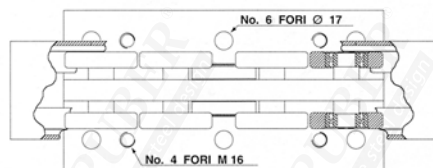

$$L = L1 + L2$$

$$L2 = 30\% \text{ von } L1$$

	D	A	H	H1	S	B	B2	C	L1 max	portata Tragkraft capacity kg	per guida für Schiene for guide kg	L	H	A	B	C	S	Lunghezza Länge Length	Peso Gewicht Weight	
58452	48	12,5	139,5	52,5	10	52,5	140	190	3m	450kg	958	58402	70	60	22	53	3,5	3m	5,55kg/m	
												58403	70	60	22	53	3,5	6m	5,55kg/m	
58450	70	15	162	74	10	72	150	300	8m	600kg	17,5	58400	94	87	33	73	5	3m	10kg/m	
												58401	94	87	33	73	5	6m	10kg/m	
58350	120	30	246	131	15	99	200	470	16m	1200kg	44,6	58300	136	142	38	100	55	6	3m	21,51kg/m
												58301	136	142	38	100	55	6	6m	21,51kg/m

ruota di sostegno · Aufrolle · support wheel

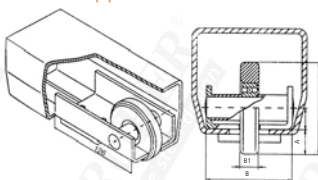

guida per cancelli sospesi
Schiene für Hängetore
guide for suspended gates
zincata · verzinkt · galvanized

58400
58401
58300
58301

	B	B1	L	A	D	per guida für Schiene for guide kg
58457	50	15	125	12	68	58402-03 1,02
58455	68	15	125	15	74	58400-01 1,2
58355	105	30	165	14	98	58300-01 3,25

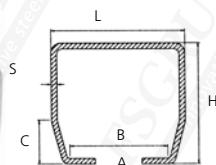
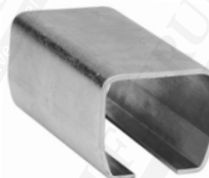



accessoires for gate carriage

piastra guidacancello · Führungsbügel · gate drive plate

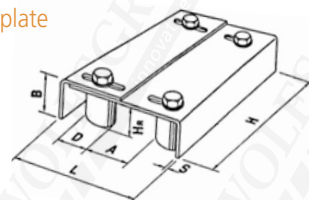
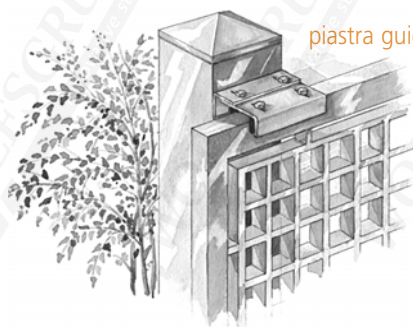

	L	H	S	A	B	ØD	Hr	
	min/max			min/max				
58410	130/170	200	3	35/60	55	30	40	2,18 kg
58420	195/245	350	5	65/85	67	40	60	5,13 kg

rotoli guide in nylon · Führungsrollen aus Nylon · nylon rollers

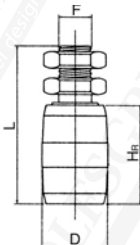

	ØD	Hr	L	F	
58412	30	40	73	M14	0,15 kg
58422	40	60	96	M16	0,42 kg

incontro · Anschlagshuh · meeting point

tappo di copertura · Abdeckkappe · cap

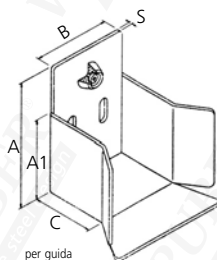

	A	A1	B	C	S	
58406	130	80	80	75	4	58402-03
58405	165	105	100	80	4	58400-01
58305	225	165	155	80	4	58300-01

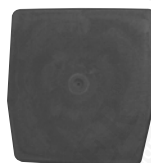

per guida
für Schiene
for guide

58407	58400-01
58307	58300-01
58408	58402-03



tabella di calcolo - Berechnungstabelle - computation table

Carello
Rollbock
Carriage

cancello - Tor - gate

fondazione - Fundament - foundation

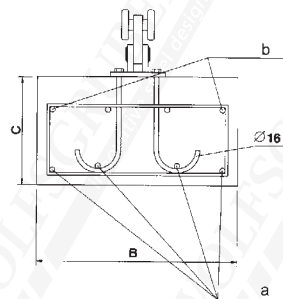
	cancello - Tor - gate				C compressione Druckbelastung pressure load	T carico di trazione Zugbelastung tensile load	forza di trazione per vite Zugkraft pro Schraube tractive force per screw	fondazione - Fundament - foundation					
	L1	L2	H	L3				A	B	C	cesto Korb basket		
	m	m	m	m				m	m	m	kg	a	b
58452	3,0	1,0	1,0	1,0	1450	850	250	1,8	0,6	0,5	1150	Ø12	Ø12
58450	4,0	1,3	1,0	1,0	1900	1150	300	2,8	0,6	0,4	1500	Ø12	Ø12
	5,0	1,5	1,0	1,5	2650	1550	400	3,4	0,6	0,4	2300	Ø12	Ø12
	6,0	1,8	1,0	1,5	3100	1800	500	4,0	0,6	0,4	2750	Ø12	Ø12
	8,0	2,4	1,0	1,5	4500	2550	650	4,6	0,6	0,4	4250	Ø12	Ø12
58350	10,0	3,0	1,0	2,0	5450	3100	800	5,2	0,6	0,4	5350	Ø12	Ø12
	12,0	4,0	1,0	2,0	7300	4050	1050	5,8	0,8	0,5	7300	Ø12	Ø12
	14,0	4,2	1,0	2,0	8450	4650	1200	6,4	0,8	0,5	8500	Ø12	Ø12
	16,0	4,8	1,0	2,0	11800	6500	1650	7,0	0,8	0,6	12150	10Ø18	Ø12

accessoires for gate carriage

galvanizzati
galvanisch verzinkt
galvanised

carrello per cancelli sospesi · Wagen für Hängetore · carriage for suspended gates

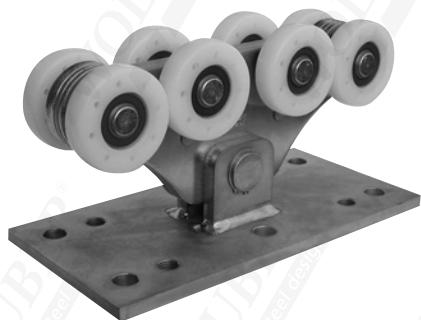

58850

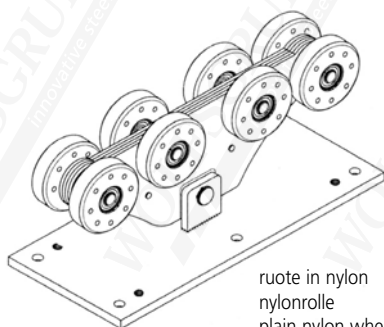

ruote in nylon
nylonrolle
plain nylon wheel



ruota a supporto interno · Laufrolle mit interner Stützplatte · wheel with internal support

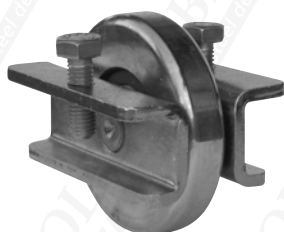

58855

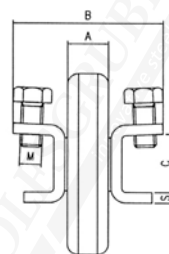
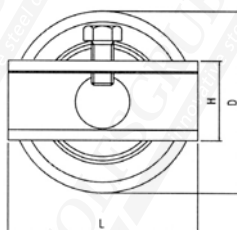

A = 15
B = 60
C = 22
D = 68
H = 30
L = 70
M = M8
S = 4

incontro · Anschlagschuh · stop point

tappo di copertura · Abdeckkappe · cap



58405

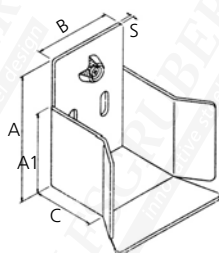

58860

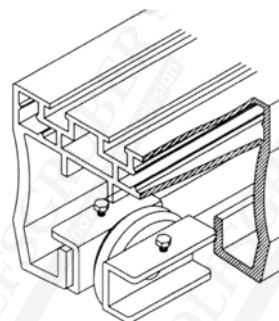



accessoires for gate carriage

guida per cancelli sospesi
Schiene für Hängetore
guide for suspended gates

alluminio
Aluminium
aluminium

Capacità di carico max 350kg a 6m
Maximale Tragfähigkeit 350kg bei 6m
Maximum load rating 350kg on 6m

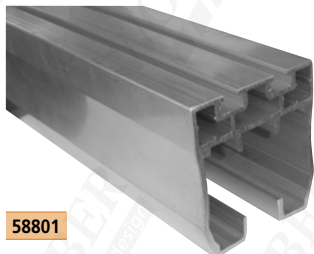

58801

L=6 m

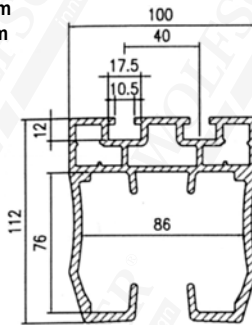

racordo
Verbindungsstift
connecting poece



58803

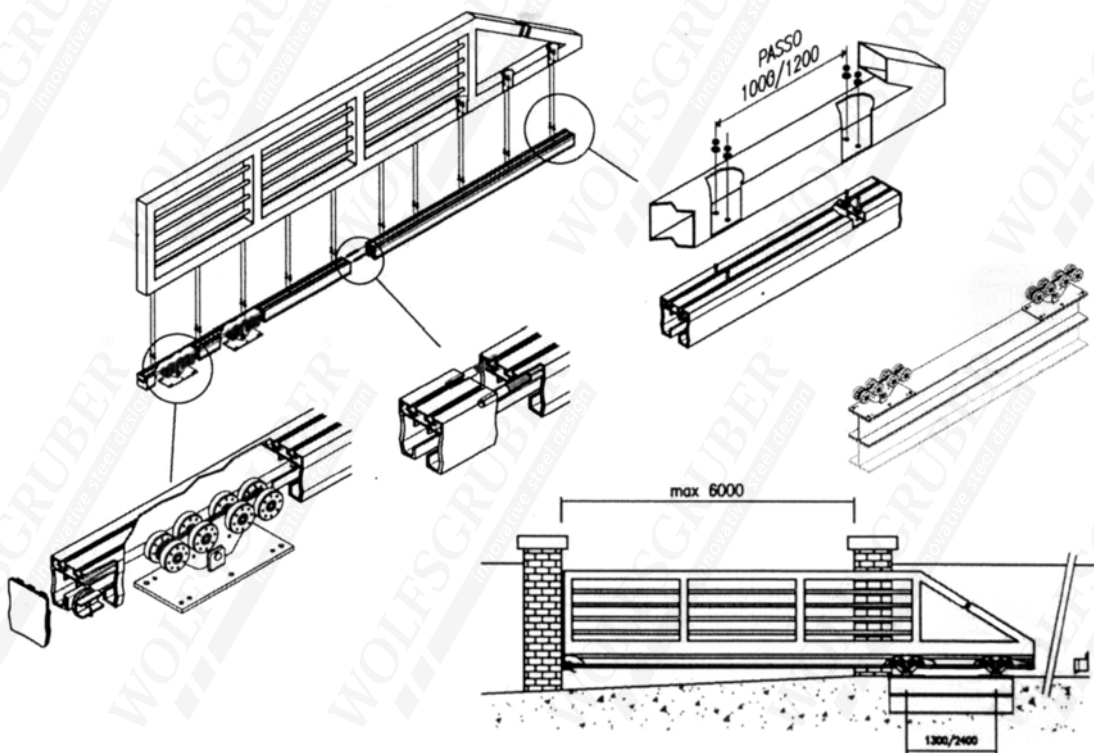

accessoires for gate carriage

Set-58403

Set per cancello autoportante fino a 450kg e luce 4m
 Laufwerkset bis 450 kg für lichte Durchfahrt bis 4m



2 x Art. 58457

2 x Art. 58452



1 x Art. 58403 6m

2 x Art. 58406

2 x Art. 58408

Set-58400

Set per cancello autoportante fino a 600kg e luce 6m
 Laufwerkset bis 600 kg für lichte Durchfahrt bis 6m



2 x Art. 58455

2 x Art. 58450



1 x Art. 58400 3m

2 x Art. 58405

2 x Art. 58407

Set-58801

Set per cancello autoportante con profilo in alluminio fino a 350kg e luce 4m
 Laufwerkset mit Aluminiumprofil bis 350 kg für lichte Durchfahrt bis 4m

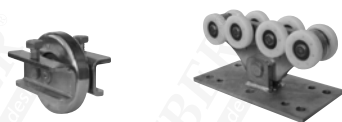

2 x Art. 58855

2 x Art. 58850



1 x Art. 58801 6m

2 x Art. 58405

2 x Art. 58860

ART.	L1 (m)	L2 (m)	L3 MAX (m)	L4 (m)	LT (m)	E (mm)	Cancello/Tor kg	kg/m	A (m)
58452	3	1	1	1,8	4,8	190	450	95	1,8
	4	1	1	2	6	190	450	75	1,8
58450	4	1,3	1	2,3	6,3	300	600	95	2,5
	5	1,5	1,5	2,5	7,5	300	600	80	2,8
	6	1,8	1,5	2,8	8,8	300	600	70	3,2
	8	2,4	1,5	3,4	11,4	300	600	55	3,7
58850	3	1	1	1,8	4,8	300	350	80	1,8
	4	1,3	1	2,3	6,3	300	350	60	2,5
	5	1,5	1,5	2,5	7,5	300	350	50	2,8
	6	1,8	1,5	2,8	8,8	300	350	40	3,2

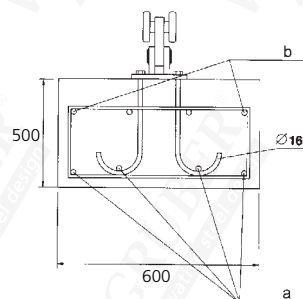
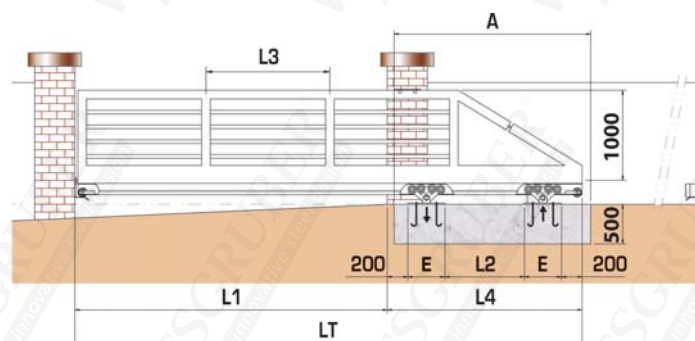

PRODOTTI FINITI
FERTIGWARE
FINISHED PRODUCTS



WOLFSGRUBER



innovative steel design

Metallfarbe Vernici speciali epossidiche-acriliche per uso interno ed esterno

La qualità superiore delle vernici epossidiche-acriliche si manifesta nella loro resistenza agli agenti atmosferici ed alla luce. Sono diluibili con diluente sintetico oppure nitro, con brevi tempi di essiccazione, ottima adesione e resistenza all'abrasione, di lunga durata.

Le vernici epossidiche-acriliche speciali sono ideali per l'artigianato del ferro battuto, si possono applicare senza strato intermedio su superfici appena zincate. Il prodotto va diluito con diluente sintetico oppure con nitro e può essere applicato a pennello, spruzzo ed immersione.

Per l'applicazione a pennello il prodotto va applicato quasi puro, mentre per l'applicazione a spruzzo o ad immersione si diluisce con 15 - 20 % con diluente sintetico oppure nitro

Gli oggetti da verniciare devono essere privi di ruggine, olio e grassi.



Metallfarbe Epoxyd-Acryl-Speziallacke für innen und außen

Epoxyd-Acryl-Speziallacke zeichnen sich durch ihre Licht und Wetterfestigkeit aus;

Sie sind schnell trocknend, haben eine sehr gute Haftung, sind abriebfest und dauerhaft.

Epoxyd-Acryl-Speziallacke sind ideal für alle Kunstschmiedearbeiten, weil sie ohne Zwischenanstrich sofort auf frisch verzinkte Oberflächen aufgebracht werden können und zum Streichen, Spritzen und Tauchen geeignet sind.

Zum Streichen fast unverdünnt, zum Tauchen und Spritzen mit 15 - 20 % Nitroverdünnung zu verarbeiten.

Die zu lackierenden Teile müssen frei von Rost, Öl und Fett sein.

Metallfarbe Epoxydic-acrylic special paints for interior and exterior use

Epoxydic-acrylic special paints are fast to light and extremely weatherresistant;

They are fast drying and show extreme adhesion and abrasion resistance which make them much more durable.

Epoxydic-acrylic special paints are ideal for the iron-forging handcraft, because they can be applied immediately even on freshly galvanized surfaces without intermediate coat.

They are suitable for brushing, spraying as for dipping.

They are to be diluted with synthetic diluent or nitro.

For brushcoating use it almost pure, for dip coating and spraying add 15 - 20 % synthetic diluent or nitro. The objects must be free of rust, oil or grease.

	RAL	Art.
<p>nero-opaco serico Schwarz-seidenmatt black-silky dull</p>	2,5 lt.	80017
<p>antracite metallizzato Anthrazit-grau, metallisch (Schmiedeantik) anthracite grey, metallic</p>	2,5 lt.	80022
<p>bianco-opaco serico Weiß-seidenmatt white-silky dull</p>	2,5 lt.	80027





resistente agli agenti atmosferici • Wetterfest • weather proof

Patina oro Patina gold Patina gold	0,250 lt.	Art. 80110
Patina oro chiaro Patina hellgold Patina gold light	0,250 lt.	80115
Patina argento Patina silber Patina silver	0,250 lt.	80120
Patina rosso rubino Patina rubinrot Patina ruby red	0,250 lt.	80125
Patina rosa antico Patina altrosa Patina antique pink	0,250 lt.	80130
Patina blu acqua Patina wasserblau Patina water blue	0,250 lt.	80135
Patina blu scuro Patina dunkelblau Patina dark blue	0,250 lt.	80138
Patina verde reseda Patina resedagrün Patina reseda green	0,250 lt.	80140
Patina verde scuro Patina dunkelgrün Patina dark green	0,250 lt.	80145
Patina verde Patina grün Patina green	0,250 lt.	80148
Patina marrone scuro Patina dunkelbraun Patina brown	0,250 lt.	80150
Patina giallo Patina gelb Patina yellow	0,250 lt.	80155

INOX AISI 304 satinato - Edelstahl W.1.4301 geschliffen - stainless steel AISI 304 satined



ART.	DIM. (AxBxH)	IP
69402	90x245x230	44



diffusore polycarbonato opale
Diffuser Polykarbonat opal
diffuser polycarbonate opal



ART.	DIM. (AxBxH)	IP
69404	90x245x230	44



diffusore polycarbonato opale
Diffuser Polykarbonat opal
diffuser polycarbonate opal



ART.	DIM. (AxBxH)	IP
69406	90x245x230	44



diffusore polycarbonato opale
Diffuser Polykarbonat opal
diffuser polycarbonate opal



ART.	DIM. (AxBxH)	IP
69408	220x110x320	44



diffusore polycarbonato opale
Diffuser Polykarbonat opal
diffuser polycarbonate opal



ART.	DIM. (AxBxH)	IP
69410	130x120x230	44



diffusore polycarbonato opale
Diffuser Polykarbonat opal
diffuser polycarbonate opal



ART.	DIM. (AxBxH)	IP
69412	160x130x340	43



diffusore polycarbonato opale
Diffuser Polykarbonat opal
diffuser polycarbonate opal



ART. DIM. (AxBxH) IP
69414 120x130x270 43



diffusore polycarbonato opale
Diffuser Polycarbonat opa
diffuser polycarbonate opal



ART. DIM. (AxBxH) IP
69416 240x130x340 43



diffusore vetro trasparente
Diffuser Klarglas
diffuser glass transparent



ART. DIM. (AxBxH) IP
69418 240x130x300 43

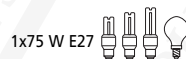

diffusore vetro trasparente
Diffuser Klarglas
diffuser glass transparent



ART. DIM. (AxBxH) IP
69420 270x135x270 43



diffusore vetro trasparente
Diffuser Klarglas
diffuser glass transparent



ART. DIM. (AxBxH) IP
69422 205x130x300 43



diffusore vetro trasparente
Diffuser Klarglas
diffuser glass transparent



ART. DIM. (AxBxH) IP
69424 145xØ255 43



diffusore polycarbonato opale
Diffuser Polycarbonat opa
diffuser polycarbonate opal

INOX AISI 304 satinato - Edelstahl W.1.4301 geschliffen - stainless steel AISI 304 satined



ART.	DIM. (AxBxH)	IP
69426	85x200x400	44

1x20 W E27



diffusore vetro opale
Diffuser Opalglas
diffuser popal glass



ART.	DIM. (AxBxH)	IP
69428	80x140x380	44

1x24 W TC-L



diffusore vetro opale
Diffuser Opalglas
diffuser popal glass



ART.	DIM. (AxBxH)	IP
69430	115x130x370	44

1x100 W E27



diffusore vetro trasparente
Diffuser Klarglas
diffuser glass trasparent



ART.	DIM. (AxBxH)	IP
69442	300xØ90x390	43

1x23 W E27



diffusore polycarbonato opale
Diffuser Polycarbonat opal
diffuser polycarbonate opal



ART.	DIM. (AxBxH)	IP
69444	135xØ90x390	43

1x23 W E27



diffusore polycarbonato opale
Diffuser Polycarbonat opal
diffuser polycarbonate opal



ART.	DIM. (AxBxH)	IP
69450	260x230x365	43

1x75 W E27



diffusore polycarbonato opale
Diffuser Polycarbonat opal
diffuser polycarbonate opal



ART.	DIM. (AxBxH)	IP
69452	260x1225	43

1x75 W E27



diffusore polycarbonato opale
Diffuser Polycarbonat opal
diffuser polycarbonate opal



ART.	DIM. (AxBxH)	IP
69446	Ø130x1100	43

1x75 W E27



diffusore polycarbonato opale
Diffuser Polycarbonat opal
diffuser polycarbonate opal



CASSETTE POSTALI - BRIEFKÄSTEN - LETTER BOXES

INOX AISI 304 satinato - Edelstahl W.1.4301 geschliffen - stainless steel AISI 304 satined



ART. DIM. (AxBxH)
69512 390x170x340



ART. DIM. (AxBxH)
69514 395x130x370



ART. DIM. (AxBxH)
69516 400x160x340



ART. DIM. (AxBxH)
69518 330x200x480



ART. DIM. (AxBxH)
69520 375x160x440



ART. DIM. (AxBxH)
69522 375x170x430



INOX AISI 304 satinato - Edelstahl W.1.4301 geschliffen - stainless steel AISI 304 satined



ART. DIM. (AxBxH)
69524 320x130x470



ART. DIM. (AxBxH)
69526 395x115x110



ART. DIM. (AxBxH)
69542 375x165x1250



ART. DIM. (AxBxH)
69544 390x160x430

numeri vivici - Hausnummern - bell push



ART.	MAT.	ART.	MAT.
69550	"0"	69557	"7"
69551	"1"	69558	"8"
69552	"2"	69559	"9"
69553	"3"	69550-a	"a"
69554	"4"	69550-b	"b"
69555	"5"	69550-c	"c"
69556	"6"	69550-d	"d"

campanelli - Klingelknöpfe - house nimbors



ART. MAT.
69561 Ø75



ART. MAT.
69562 180x60

Ariete - Widder - Aries



ART. KG
81005 0,64

Toro - Stier - Taurus



ART. KG
81010 0,56

Gemelli - Zwillinge - Gemini



ART. KG
81015 0,62

Cancro - Krebs - Cancer



ART. KG
81020 0,58

Leone - Löwe - Leo



ART. KG
81025 0,56

Vergine - Jungfrau - Virgo



ART. KG
81030 0,64

Bilancia - Waage - Libra



ART.	KG
81035	0,54

Scorpione - Skorpion - Scorpio



ART.	KG
81040	0,56

Sagittario - Schütze - Sagittarius



ART.	KG
81045	0,66

Capricorno - Steinbock - Capricorn



ART.	KG
81050	0,58

Acquario - Wassermann - Aquarius



ART.	KG
81055	0,60

Pesci - Fische - Pisces



ART.	KG
81060	0,56

cervo - Rehbock - stag



ART.	KG
81110	1,12

urogallo - Auerhahn - capercaillie



ART.	KG
81120	1,16

cavallo - Pferd - horse



ART.	KG
81130	1,22

anitra selvatica - Wildente - wild duck



ART.	KG
81140	0,98

airone - Fischreiher - heron



ART.	KG
81150	1,10

passero - Spatz - sparrow



ART.	KG
81210	0,60

scoiattolo - Eichhörnchen - squirrel



ART.	KG
81220	0,56

cavalluccio marino - Seepferdchen - sea-horse



ART.	KG
81230	0,52

pesce - Fisch - fish



ART.	KG
81240	0,54



ART.	KG
81300	7,78

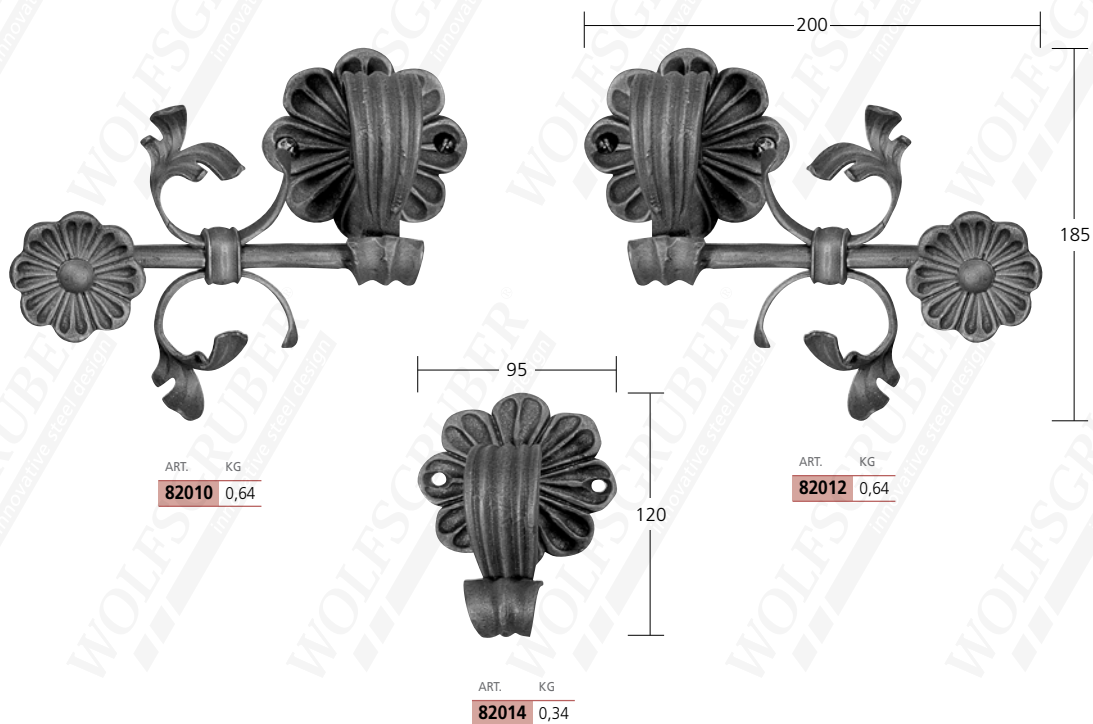

ganci attaccapanni - Garderobenhaken - coat hooks

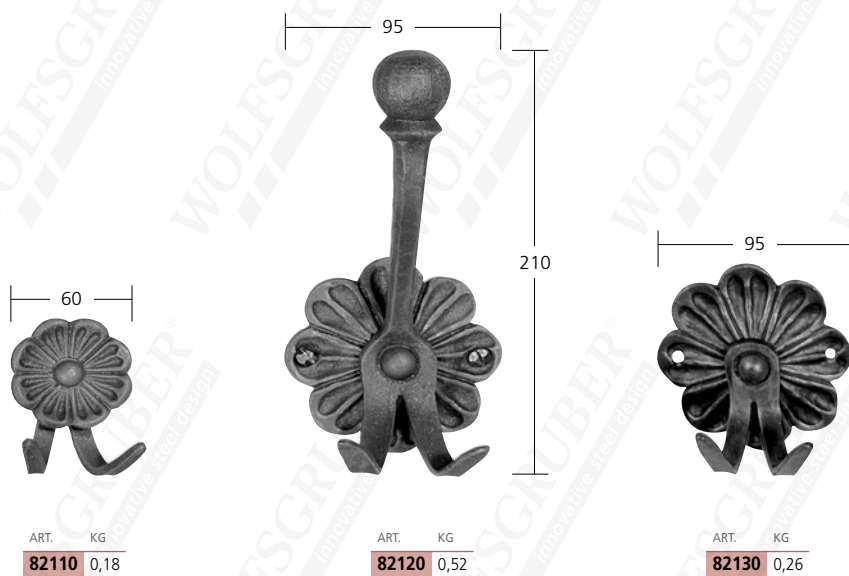



ART.	KG
83010	7,06



ART.	KG
83020	4,10



ART.	KG
84010	1,02



ART.	KG
84020	0,70

B

H



510

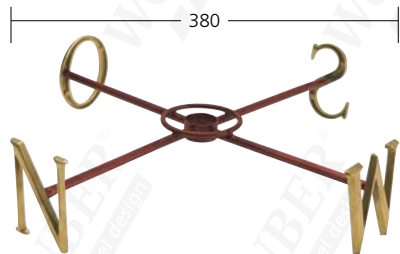

380

rame - Kupfer - copper

ART.	BxH MM	KG
84210	330x455	1,04
84220	550x600	2,14

ART.	KG
84240	0,38

ART.	KG	Ø
84230	0,54	28

450



ART.
81160

330



ART.
81162

225



ART.
81164

570

200



ART.
81168

300

380



ART.
81166

440



ferro - Eisen - iron



ART. KG
85010 2,80

bronzo - Bronze - bronze



ART. KG
85020 2,52



ART.
85022



ART.
85024



ART.
85026



ART.
85028



ART.
85030



ART.
85125



ART.
85130



ART.	BxH MM	KG
85110	215x310	1,38
85120	280x410	3,30

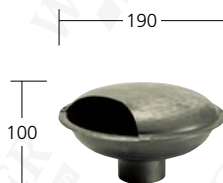

ART.	KG
85210	0,56



ART.	KG
85220	0,70



ART.
85225

**OTTONE
MESSING
BRASS**



laminati a caldo • warm gewalzt • rolled with heat



ART.	MAT.	KG
20512	54x8 mm	1,61



ART.	MAT.	KG/m
20510	54x8x3000 mm	2,69

bronzo da forgia
Schmiedebronze
bronze forged



ART.	MAT.	KG
20514	54x8 mm	1,61

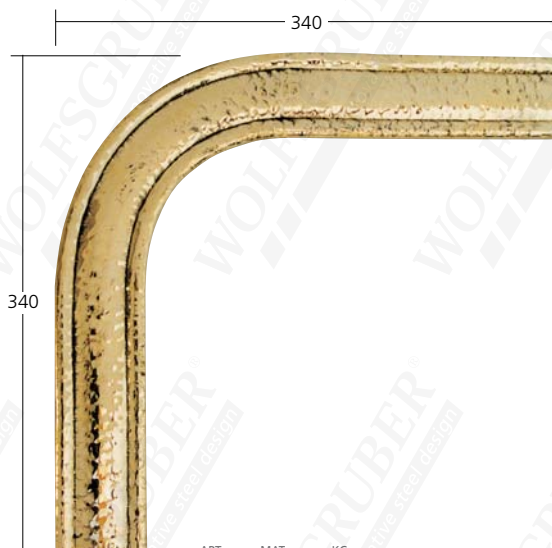

ART.	MAT.	KG
20516	54x8 mm	1,61

laminati a caldo • warm gewalzt • rolled with heat

ART.	MAT.	KG
20522	54x8 mm	1,85
20532	42x8 mm	1,38



ART.	MAT.	KG
20520	54x8x3000 mm	3,09
20530	42x8x3000 mm	2,30



bronzo da forgia
Schmiedebronze
bronze forged



ART.	MAT.	KG
20524	54x8 mm	1,85
20534	42x8 mm	1,38



ART.	MAT.	KG
20526	54x8 mm	1,85
20536	42x8 mm	1,38



laminati a caldo • warm gewalzt • rolled with heat



ART.	MAT.	KG
20542	45x15 mm	1,69



ART.	MAT.	KG/m
20540	45x15x3000 mm	2,81



ART.	MAT.	KG
20544	45x12 mm	1,69

laminati a caldo • warm gewalzt • rolled with heat

ART.	MAT.	KG
20552	50x15 mm	2,30



ART.	MAT.	KG/m
20550	50x15x3000 mm	3,83



ART.	MAT.	KG
20554	45x15 mm	2,30

ottone lucidato e verniciato a forno • Messing hochglanzpoliert und einbrennlackiert • brass highly polished, stove enamelled



ART.	PER TUBE FÜR ROHR FOR TUBE	KG
22411	Ø33,7	0,22
22412	Ø42,4	0,23



ART.	PER TUBE FÜR ROHR FOR TUBE	KG
22421	Ø33,7	0,25
22422	Ø42,4	0,28



ART.	PER TUBE FÜR ROHR FOR TUBE	KG
22431	Ø33,7	0,25
22432	Ø42,4	0,28

giunti sferici - Kugelgelenke - ball-and-socket joints



ART.	PER TUBE FÜR ROHR FOR TUBE	KG
22451	Ø33,7	0,23
22452	Ø42,4	0,27



ART.	PER TUBE FÜR ROHR FOR TUBE	KG
22456	Ø33,7	0,32
22457	Ø42,4	0,37

piastrina di base
Bodenrosetten
base rosette



ART.	Ø D mm	KG
22460	12	0,28
22462	14	0,30
22464	25	0,35
22466	42,4	0,38

mensola d'angolo
Eckkonsole
edge console

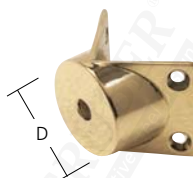

ART.	Ø D mm	KG
22470	42,4	0,08



ottone lucidato e verniciato a forno • Messing hochglanzpoliert und einbrennlackiert • brass highly polished, stove enamelled

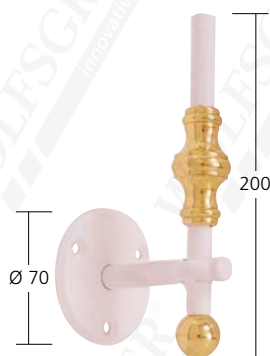

ART.	FORO LOCH HOLE	KG	FILETTO GEWINDE THREAD
22010	Ø30 mm	1,12	M 14

ART.	FORO LOCH HOLE	KG	FILETTO GEWINDE THREAD
22020	Ø30 mm	0,34	M 8

ART.	FORO LOCH HOLE	KG
22030	Ø30 mm	0,78

ART.	MAT.	KG
22040	Ø14 mm	0,78

esempi d'impiego - Anwendungsbeispiele - examples of application





sfere cave
Hohlkugeln
hollow spheres

ART.	Ø mm	FILETTO GEWINDE THREAD	KG	dorado vergoldet gilder
70050	50	M 8	0,15	Art. 7G0050
70065	65	M 10	0,30	Art. 7G0065
70075	75	M 10	0,39	Art. 7G0075
70085	85	M 10	0,51	Art. 7G0085
70100	100	M 10	0,53	Art. 7G0100
70120	120	M 10	1,06	



sfere piene
Massivkugeln
hallow spheres

ART.	Ø mm	FILETTO GEWINDE THREAD	KG	dorado vergoldet gilder
70220	20	M 6	0,03	Art. 7G0220
70225	25	M 6	0,06	Art. 7G0225
70230	30	M 6	0,11	Art. 7G0230
70235	35	M 8	0,18	Art. 7G0235
70240	40	M 8	0,27	Art. 7G0240



sfere piene con foro cieco
Massivkugeln mit Sackloch
solid spheres with blind hole

ART.	MAT.	FOUR LOCH HOLE	dorado vergoldet gilder
71271	Ø20	Ø10,3	
71272	Ø20	Ø12,3	Art. 7G1272
71274	Ø20	Ø14,3	Art. 7G1274
71276	Ø25	Ø12,3	Art. 7G1276
71278	Ø25	Ø14,3	Art. 7G1278



sfere piene tornite
Massivkugeln drehblank
solid spheres bright late worked

ART.	Ø mm	FILETTO GEWINDE THREAD	KG
70410	10	M 4	0,01
70412	12	M 4	0,01
70414	14	M 5	0,01
70416	16	M 5	0,02
70420	20	M 6	0,03
70425	25	M 6	0,06
70430	30	M 6	0,11
70435	35	M 8	0,18
70440	40	M 8	0,27

ottone lucidato e verniciato a forno • Messing hochglanzpoliert und einbrennlackiert • brass highly polished, stove enamelled

dorato
vergoldet
gilder
Art. 7G1030

ART.	SEDE ANSATZ LUG	FILETTO GEWINDE THREAD	KG
71030	Ø16 mm	M 6	0,05

dorato
vergoldet
gilder
Art. 7G1050

ART.	SEDE ANSATZ LUG	FILETTO GEWINDE THREAD	KG
71050	Ø30 mm	M 10	0,19

dorato
vergoldet
gilder
Art. 7G1058

ART.	SEDE ANSATZ LUG	FILETTO GEWINDE THREAD	KG
71058	Ø34 mm	M 10	0,27

dorato
vergoldet
gilder
Art. 7G1075

ART.	SEDE ANSATZ LUG	FILETTO GEWINDE THREAD	KG
71075	Ø42,8 mm	M 10	0,50

dorato
vergoldet
gilder
Art. 7G1085

ART.	SEDE ANSATZ LUG	FILETTO GEWINDE THREAD	KG
71085	Ø42,8 mm	M 10	0,72
	Ø48,8 mm		



ottone lucidato e verniciato a forno • Messing hochglanzpoliert und einbrennlackiert • brass highly polished, stove enamelled



ART.	SEDE ANSATZ LUG	FILETTO GEWINDE THREAD	KG
71243	Ø30 mm	M 10	0,18



ART.	SEDE ANSATZ LUG	FILETTO GEWINDE THREAD	KG
71260	Ø30 mm	M 10	0,27



ART.	FILETTO GEWINDE THREAD	KG
71255	M 8	0,28



ART.	SEDE ANSATZ LUG	FILETTO GEWINDE THREAD	KG
71250	Ø26 mm	M 10	0,25



ART.	FILETTO GEWINDE THREAD	KG
71328	M 6	0,04



ART.	FILETTO GEWINDE THREAD	KG
71318	M 10x1 - M 6	0,04



ART.	FILETTO GEWINDE THREAD	KG
71330	M 10x1 - M 6	0,10



ART.	FILETTO GEWINDE THREAD	KG
71333	M 10	0,10



ART.	FILETTO GEWINDE THREAD	KG
71343	M 10	0,16

ottone lucidato e verniciato a forno • Messing hochglanzpoliert und einbrennlackiert • brass highly polished, stove enamelled



ART.	MAT.	FOUR LOCH HOLE	KG
71252	Ø20x16	Ø12,3	kg
71254	Ø20x16	Ø14,3	kg

dorado
vergoldet
gilder
Art. 7G1252
Art. 7G1254

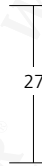
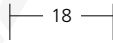

ART.	SEDE ANSATZ LUG	KG
71432	Ø12 mm	0,02

dorado
vergoldet
gilder
Art. 7G1432



ART.	MAT.	FOUR LOCH HOLE	KG
71262	Ø20x16	Ø12,3	kg
71264	Ø20x16	Ø14,3	kg

dorado
vergoldet
gilder
Art. 7G1262
Art. 7G1264

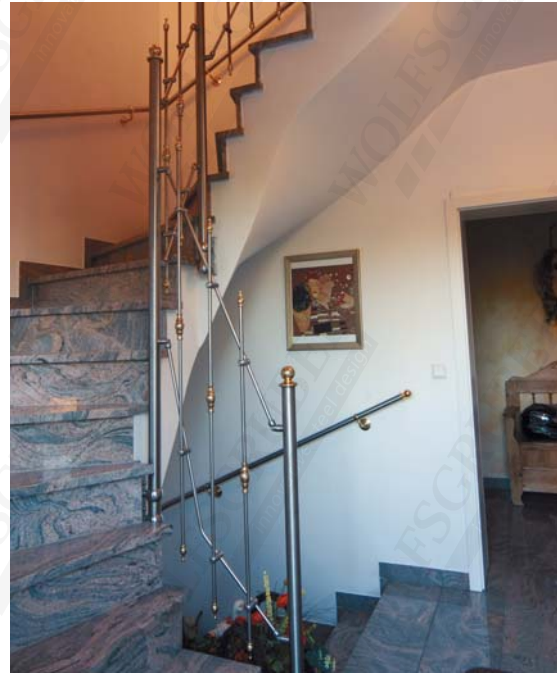

tornti - Drehblank - lathe worked

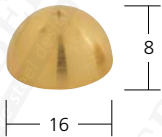

ART.	FILETTO GEWINDE THREAD	KG
71410	M 10x1 - M 6	0,01

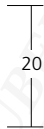

ART.	FILETTO GEWINDE THREAD	KG
71415	M 10x1 - M 6	0,01

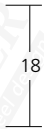

ART.	FILETTO GEWINDE THREAD	KG
71420	M 10x1 - M 6	0,01

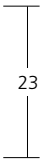

ART.	FILETTO GEWINDE THREAD	KG
71425	M 10x1 - M 6	0,01

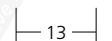

ART.	FILETTO GEWINDE THREAD	KG
71430	M 10x1 - M 6	0,02



ART.	FILETTO GEWINDE THREAD	KG
71435	M 10x1 - M 6	0,05

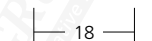
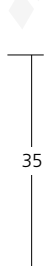

ART.	FILETTO GEWINDE THREAD	KG
71440	M 10x1 - M 6	0,05



riduzione
Reduzierung
reduction



ART.	FILETTO GEWINDE THREAD
71820	M 10x1 - M 6

bussole con filetto esterno
Gewindehülsen
threaded coupling

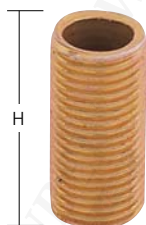

ART.	FILETTOG EWINDE THREAD	H
71830	M 10x1	20
71840	M 10x1	40

inserto per fissaggio di finali
Verschraubungseinsatz
thread joint



ART.	FILETTO GEWINDE THREAD	PER TUBI FÜR ROHRE FOR TUBES	KG
71850	M 10	Ø30	0,006
71855	M 10	Ø42,4	0,018

ottone lucidato e verniciato a forno • Messing hochglanzpoliert und einbrennlackiert • brass highly polished, stove enamelled

dadi ciechi con calotta sferica
Hutmutter
cap nuts



ART.	FILETTO GEWINDE THREAD
71815	M 5
71816	M 6

dado
Mutter
hexagon nut



ART.	FILETTO GEWINDE THREAD
71810	M 10x1



ART.	FORO LOCH HOLE	KG
72170	Ø10	0,09



ART.	FORO LOCH HOLE	KG
72175	Ø10	0,10



ART.	FORO LOCH HOLE	KG
72180	Ø10	0,10



ART.	Ø mm	H mm	FORO LOCH HOLE	KG
72185	85	33	Ø10	0,16
72188	96	37	Ø10	0,30

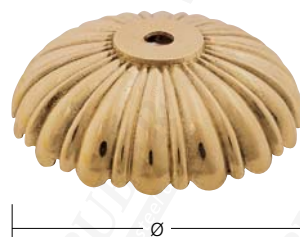

ART.	Ø mm	H mm	FORO LOCH HOLE	KG
72190	90	34	Ø10	0,16
72195	110	34	Ø10	0,25

ottone lucidato e verniciato a forno • Messing hochglanzpoliert und einbrennlackiert • brass highly polished, stove enamelled



ART.	FORO LOCH HOLE	KG
72245	Ø10	0,02

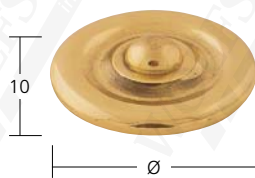

ART.	Ø mm	FILETTO GEWINDE THREAD	KG
72236	36	M 8	0,04
72250	50	M 8	0,06



ART.	FORO LOCH HOLE	KG
72258	Ø10	0,06



ART.	FORO LOCH HOLE	KG
72265	M 5	0,08

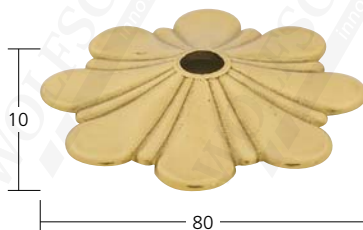

ART.	FORO LOCH HOLE	KG
72280	Ø10	0,06

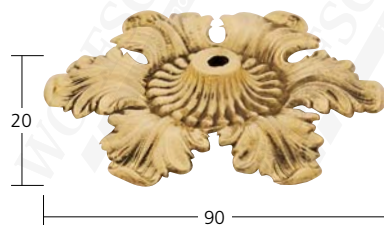

ART.	FORO LOCH HOLE	KG
72290	Ø10	0,06

lucidate e protette con nylon - poliert und foliengeschützt - polished and foil coated



ART.	Ø mm	SPESSORE STÄRKE THICKNESS	KG
73033	33	4 mm	0,03
73040	40	4 mm	0,04
73050	50	4 mm	0,07
73060	60	4 mm	0,09
73070	70	4 mm	0,13
73080	80	6 mm	0,25
73100	100	6 mm	0,40



ART.	Ø mm	SPESSORE STÄRKE THICKNESS	KG
73255	55	4 mm	0,06
73292	92	4 mm	0,18

ottone lucidato e verniciato a forno • Messing hochglanzpoliert und einbrennlackiert • brass highly polished, stove enamelled



ART.	FORO LOCH HOLE	KG
74030	Ø14	0,16



ART.	FILETTO GEWINDE THREAD	KG
74032	Ø22,4	0,43
74035	Ø25,4	0,34



ART.	FORO LOCH HOLE	KG
74038	Ø22,4	0,44
74040	Ø25,4	0,38



ART.	FORO LOCH HOLE	KG
74042	Ø25,4 mm	0,14



ART.	FORO LOCH HOLE	KG
74045	Ø12 mm	0,34



ART.	FORO LOCH HOLE	KG
74055	Ø25,4 mm	0,67



ART.	FORO LOCH HOLE	KG
74060	Ø25,4 mm	0,28



BORCHIE • ZIERHÜLSEN • ENVELOPING BODIES

ottone lucidato e verniciato a forno • Messing hochglanzpoliert und einbrennlackiert • brass highly polished, stove enamelled



dorato
vergoldet
gilder
7G5030

ART. FORO LOCH HOLE KG
75030 Ø12,2 mm 0,18



ART. FORO LOCH HOLE KG
75035 Ø16,2 mm 0,18



dorato
vergoldet
gilder
7G5020

ART. FORO LOCH HOLE KG
75020 Ø12,2 mm 0,63



dorato
vergoldet
gilder
7G5025

ART. FORO LOCH HOLE KG
75025 Ø12,2 mm 0,09



ART. FORO LOCH HOLE KG
75040 Ø14,2 mm 0,14



ART. FORO LOCH HOLE KG
75045 Ø11 mm 0,16



ART. FORO LOCH HOLE KG
75055 Ø12 mm 0,16



ART. FORO LOCH HOLE KG
75060 Ø16,2 mm 0,30

ottone lucidato e verniciato a forno • Messing hochglanzpoliert und einbrennlackiert • brass highly polished, stove enamelled



ART.	FORO LOCH HOLE	KG
75125	Ø35 Ø12,2	
75130	Ø40 Ø14,2	



ART.	FORO LOCH HOLE	KG
75135	Ø8,5 mm 0,16	

dorato
vergoldet
gilder
7G5135



ART.	FORO LOCH HOLE	KG
75140	Ø10,5 mm 0,24	

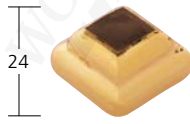

ART.	FORO LOCH HOLE	KG
75145	14,4 mm 0,08	

35x35



ART.	FORO LOCH HOLE	KG
75150	Ø14,4	
75151	Ø12,2	

dorato
vergoldet
gilder
7G5151



ART.	FORO LOCH HOLE	FILETTO GEWINDE THREAD	KG
75155	Ø28 mm	M 10x1	0,10



PARTICOLARI ORNAMENTALI • DEKORATIONSELEMENTE • ADDITIVES

ottone lucidato e verniciato a forno • Messing hochglanzpoliert und einbrennlackiert • brass highly polished, stove enamelled



ART.	KG
76130	0,10



ART.	KG
76140	0,26



ART.	FILETTO GEWINDE THREAD	KG
76075	M 10	0,08



ART.	KG
76165	0,10



ART.	FILETTO GEWINDE THREAD	KG
76170	M 10	0,34



lettere e numeri civici decorativi
 Dekorative Hausnummern - Buchstaben
 decorative house numbers and letters



ART.	FILETT GEWINDE THREAD
77010-0	M 6
" - "	"
" - "	"
" - "	"
77010-9	M 6



ART.	FILETT GEWINDE THREAD
77020-a	M 6
" -b	"
" -c	"
" -d	"
77020-e	M 6

Esclusione di responsabilità

Tutte le indicazioni vengono fornite con l'intenzione di correttezza e completezza. Wolfsgruber è grato di qualsiasi segnalazione di errori o dati mancanti. Tutti i dati contenuti in questo catalogo sono validi al momento della stampa. Ci riserviamo il diritto di modifiche ai fini di un continuo miglioramento tecnico o correzione di errori.

Copyright

Il presente catalogo è proprietà intellettuale della Wolfsgruber Srl. La Wolfsgruber Srl si riserva espressamente il diritto di proprietà e di autore delle informazioni contenute nel catalogo. La ristampa e la riproduzione, anche parziali, sono consentite solo previa autorizzazione scritta della Wolfsgruber Srl.

Haftungsausschluss

Alle Angaben erfolgen mit dem Ziel der Richtigkeit und Vollständigkeit. Für Hinweise zu Irrtümern oder fehlenden Angaben ist Wolfsgruber dankbar. Alle Angaben in diesem Katalog sind gültig zur Zeit der Drucklegung. Änderungen im Sinne einer ständigen Verbesserung des Angebots sowie Irrtum sind vorbehalten.

Copyright

Dieser Katalog ist geistiges Eigentum der Wolfsgruber GmbH. Die Wolfsgruber GmbH behält sich das Eigentums- und Urheberrecht an den Katalogangaben ausdrücklich vor. Nachdruck und Vervielfältigung, auch auszugsweise, sind nur mit der vorherigen schriftlichen Genehmigung der Wolfsgruber GmbH zulässig.

Exclusion of liability

All information is given with the intention of accuracy and completeness. Wolfsgruber would appreciate any information regarding errors or missing items. All information in this catalogue is valid at the time of printing. We reserve the right to make changes related to continuous improvement of the product range or errors.

Copyright

This catalogue is the intellectual property of Wolfsgruber GmbH. Wolfsgruber GmbH expressly retains rights of ownership and copyright with regard to the information in the catalogue. Reprinting and reproduction of the text, including in part, is only permitted with the prior written permission of Wolfsgruber GmbH.

catalogue



richiedete il nostro catalogo **ACCAIO INOX**
fordern Sie unseren **EDELSTAHL** Katalog an
ask for our **STAINLESS STEEL** catalogue

service



... progettate la vostra ringhiera con pochi click!
... planen Sie Ihr Geländer mit wenigen Klicks!
... plan your railing with a few clicks!
www.railingconfigurator.com

progettiamo e realizziamo le vostre idee
wir realisieren und planen Ihre Ideen
we plan and realise your ideas



TORNITURA E FRESATURA
SPANABHEBENDE BEARBEITUNG
CHIP FORMING MACHINING

TAGLIO LASER
LASERBEARBEITUNG
LASER MACHINING

SATINATURA E LUCIDATURA
SCHLEIFEN UND POLIEREN
GRAINDING AND POLISHING

service

MONTANTI A MISURA
GELÄNDERPFOSTEN AUF MASS
BALUSTER CUSTOM MADE

SERVIZIO DI PIEGATURA
BIEGESERVICE
BENDING SERVICE

PROGETTAZIONE
PROJEKTIERUNG
ELABORATION



WOLFSGRUBER®
innovative steel design

Wolfgruber srl
Via Campi della Rienza, 6 | I-39031 Brunico (BZ)
Tel. +39 0474 552231 | Fax +39 0474 552247

Service Center
Fax +39 0474 552247
servicecenter@wolfgruber.it

Wolfgruber GmbH
Rienzfildweg 6 | I-39031 Bruneck (BZ)
www.wolfgruber.it | info@wolfgruber.it